

DATE REVISED	DATE FILMED	DATE REVISED	DATE FILMED	FED. RD. DIST. NO.	STATE	FED. AID PROJ. NO.	SHEET NO.	TOTAL SHEETS
				6	ARK.			
						JOB NO.	012260	1 61

ARKANSAS STATE HIGHWAY AND TRANSPORTATION DEPARTMENT  
CONSTRUCTION PLANS FOR STATE HIGHWAY

② STATEWIDE WRONG-WAY CRASH FREEWAY IMPVTS. (S)

STATEWIDE WRONG-WAY  
CRASH FREEWAY IMPVTS. (S)

VARIOUS COUNTIES

JOB 012260

FED. AID PROJ. HSIP-0076(121)

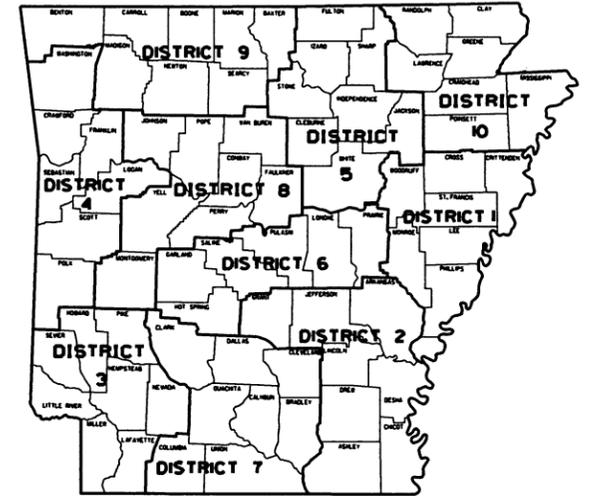

ARK. HWY. DIST. NOS. 1 - 10

APPROVED



9-30-16

DEPUTY DIRECTOR  
AND CHIEF ENGINEER

NO LENGTH INVOLVED

DATE REVISED	DATE FILED	DATE REVISED	DATE FILED	FED. RD. DIST. NO.	STATE	FED. AID PROJ. NO.	SHEET NO.	TOTAL SHEETS
10/24/16				6	ARK.			
12/13/16								
						JOB NO. 012260	2	61

2 INDEX OF SHEETS, GOV. SPECS. & GEN. NOTES

## INDEX OF SHEETS

SHEET NO.	TITLE	DRWG. NO.	DATE
1	TITLE SHEET		
2	INDEX OF SHEETS, GOVERNING SPECIFICATIONS, AND GENERAL NOTES		
3 - 6	SPECIAL DETAILS		
7 - 52	QUANTITIES		
53	SUMMARY OF QUANTITIES AND REVISIONS		
54	PAVEMENT MARKING DETAILS	PM-1	5-12-16
55	PERMANENT PAVEMENT MARKING ON ACCESS CONTROLLED ROADWAYS	PM-2	12-08-16
56	STANDARD HIGHWAY SIGNS AND SUPPORTS ASSEMBLIES	SHS-1	9-12-13
57	U-CHANNEL POST ASSEMBLIES	SHS-2	2-27-14
58	NOT USED		
59	STANDARD TRAFFIC CONTROLS FOR HIGHWAY CONSTRUCTION	TC-1	9-02-15
60	STANDARD TRAFFIC CONTROLS FOR HIGHWAY CONSTRUCTION	TC-2	9-02-15
61	STANDARD TRAFFIC CONTROLS FOR HIGHWAY CONSTRUCTION	TC-3	9-02-15

## GOVERNING SPECIFICATIONS

ARKANSAS STATE HIGHWAY COMMISSION STANDARD SPECIFICATIONS FOR HIGHWAY CONSTRUCTION, EDITION OF 2014, AND THE FOLLOWING SPECIAL PROVISIONS AND SUPPLEMENTAL SPECIFICATIONS:

NUMBER	TITLE
ERRATA	ERRATA FOR THE BOOK OF STANDARD SPECIFICATIONS
FHWA-1273	REQUIRED CONTRACT PROVISIONS FEDERAL-AID CONSTRUCTION CONTRACTS
FHWA-1273	SUPPLEMENT - EQUAL EMPLOYMENT OPPORTUNITY - NOTICE TO CONTRACTORS
FHWA-1273	SUPPLEMENT - SPECIFIC EQUAL EMPLOYMENT OPPORTUNITY RESPONSIBILITIES (23 U.S.C. 140)
FHWA-1273	SUPPLEMENT - EQUAL EMPLOYMENT OPPORTUNITY - GOALS AND TIMETABLES
FHWA-1273	SUPPLEMENT - EQUAL EMPLOYMENT OPPORTUNITY - FEDERAL STANDARDS
FHWA-1273	SUPPLEMENT - POSTERS AND NOTICES REQUIRED FOR FEDERAL-AID PROJECTS
FHWA-1273	SUPPLEMENT - WAGE RATE DETERMINATION
100-3	CONTRACTOR'S LICENSE
102-2	ISSUANCE OF PROPOSALS
108-1	LIQUIDATED DAMAGES
108-2	WORK ALLOWED PRIOR TO ISSUANCE OF WORK ORDER
JOB 012260	BARRIER WALL DELINEATOR
JOB 012260	BIDDING REQUIREMENTS AND CONDITIONS
JOB 012260	CARGO PREFERENCE ACT REQUIREMENTS
JOB 012260	DOCUMENTATION OF PAYMENTS MADE TO DISADVANTAGED BUSINESS ENTERPRISES
JOB 012260	GENERAL REQUIREMENTS FOR SIGNS
JOB 012260	MAINTENANCE OF TRAFFIC
JOB 012260	MANDATORY ELECTRONIC CONTRACT
JOB 012260	MANDATORY ELECTRONIC DOCUMENT SUBMITTAL
JOB 012260	PARTNERING REQUIREMENTS
JOB 012260	REMOVAL AND DISPOSAL OF DELINEATOR POST
JOB 012260	VALUE ENGINEERING

## GENERAL NOTES

- ALL LAND MONUMENTS LOCATED WITHIN THE CONSTRUCTION AREA SHALL BE PROTECTED IN ACCORDANCE WITH SECTION 107.12 OF THE STANDARD SPECIFICATIONS.
- ALL WRONG-WAY SIGNS, DO NOT ENTER SIGNS, AND RED VERTICAL STRIPS ON THE SIGN POSTS SHALL BE TYPE XI SHEETING. THE RED VERTICAL STRIPS ON THE SIGN POSTS SHALL BE 3"x3". ALL OTHER SIGNS SHALL BE MADE USING STANDARD TYPE III SHEETING.
- THE WRONG-WAY AND DO NOT ENTER SIGNS SHALL BE MOUNTED 3' TO THE BOTTOM OF THE SIGN ABOVE THE NEAR EDGE OF THE PAVEMENT. THE WRONG-WAY AND DO NOT ENTER SIGNS SHALL NOT OBSTRUCT MOTORIST VIEW OF THE ROADWAY.
- EXISTING SIGN POSTS THAT ARE STRAIGHT AND PLUMB AND ARE AT LEAST 15' FROM THE EDGE OF THE EXISTING ROADWAY MAY BE RETAINED AND REUSED, AS DIRECTED BY THE ENGINEER.
- PLACING NEW POSTS ON EXISTING ISLANDS THAT ARE CONCRETE MAY REQUIRE CORING/ DRILLING THE CONCRETE. CORING/ DRILLING SHALL BE SUBSIDIARY TO THE INSTALLATION OF THE SIGN ASSEMBLY.
- REMOVAL AND DISPOSAL OF SIGN POSTS (EACH) SHALL INCLUDE SIGNS POSTS ON EACH SIGN ASSEMBLY. REMOVAL AND DISPOSAL OF SIGNS SHALL BE CONSIDERED SUBSIDIARY TO VARIOUS CONTRACT ITEMS.
- IF AN EXIT RAMP HAS EXISTING LANE USE ARROWS FOR MULTIPLE TURN LANES, THE WRONG-WAY ARROW SHOULD BE PLACED JUST PRIOR TO WHERE THE RAMP BEGINS TO WIDEN PAST THE TYPICAL 15' WIDTH.
- THE RED SHEETING FOR THE INCORRECT TRAFFIC DIRECTION FOR ALL DELINEATORS (TYPE 2) SHALL BE TYPE XI REFLECTIVE SHEETING.
- THE CONTRACTOR SHALL NOT CLOSE ANY LANES ON MAIN LANES, RAMPS, OR CROSS ROADS MONDAY THROUGH FRIDAY BETWEEN 7:00 A.M. TO 9:00 A.M. AND 4:00 P.M. TO 6:00 P.M., OR AS DIRECTED BY THE ENGINEER.
- SIGNS LARGER THAN 36" REQUIRE A 2 POST (U-2) SUPPORT.

INDEX OF SHEETS, GOVERNING SPECIFICATIONS, AND GENERAL NOTES

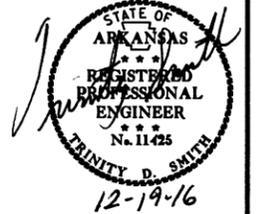



DATE REVISED	DATE FILMED	DATE REVISED	DATE FILMED	FED. DIST. NO.	STATE	FED. AID PROJ. NO.	SHEET NO.	TOTAL SHEETS
				6	ARK.			
JOB NO. 012260							4	61

2 SPECIAL DETAILS



SIGN	LEGEND	SIZE	MINIMUM NUMBER REQUIRED
R1-1	STOP	48" X 48"	2
R1-2	YIELD	48" X 48" X 48"	1
R4-7A	KEEP RIGHT	24" X 30"	1
R5-1	DO NOT ENTER	36" X 36"	2
R5-1A	WRONG WAY	42" X 30"	2
R6-1L	ONE WAY	54" X 18"	1
R6-1R	ONE WAY	54" X 18"	1

\* THE R5-1 (DO NOT ENTER) SIGN MOUNTED BACK-TO-BACK WITH THE R1-2 (YIELD) SIGN SHALL BE 30" X 30".

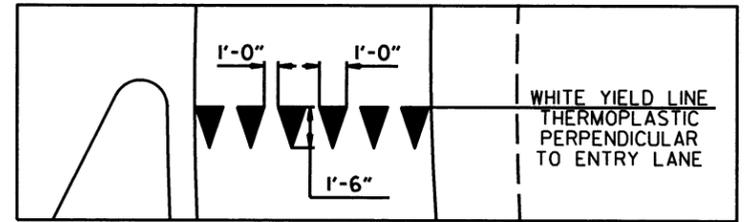
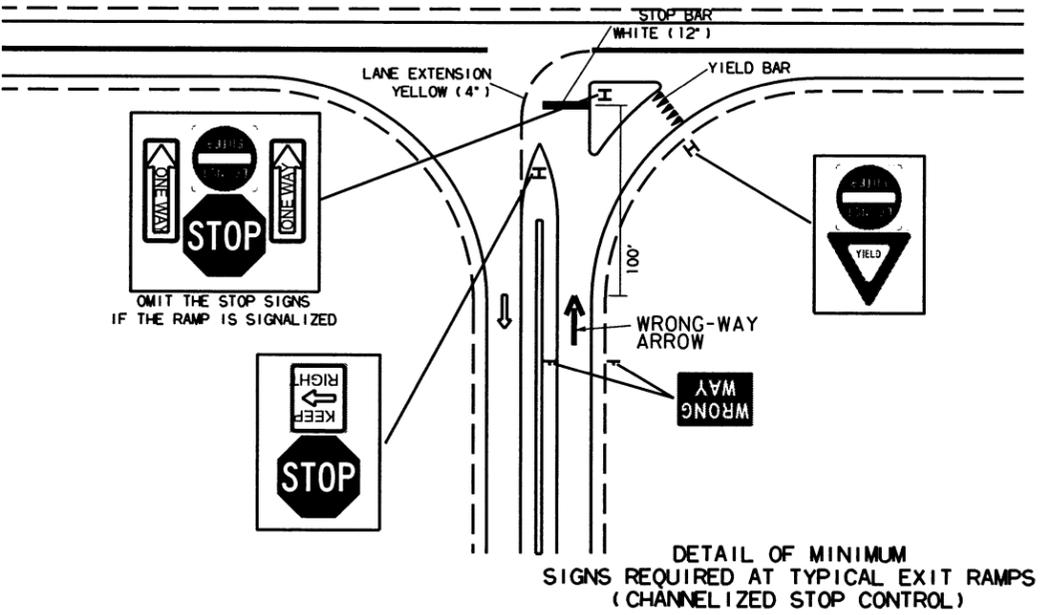

SIGN	LEGEND	SIZE	MINIMUM NUMBER REQUIRED
R1-1	STOP	48" X 48"	2
R4-7A	KEEP RIGHT	24" X 30"	1
R5-1	DO NOT ENTER	36" X 36"	1
R5-1A	WRONG WAY	42" X 30"	2
R6-1L	ONE WAY	54" X 18"	1
R6-1R	ONE WAY	54" X 18"	1

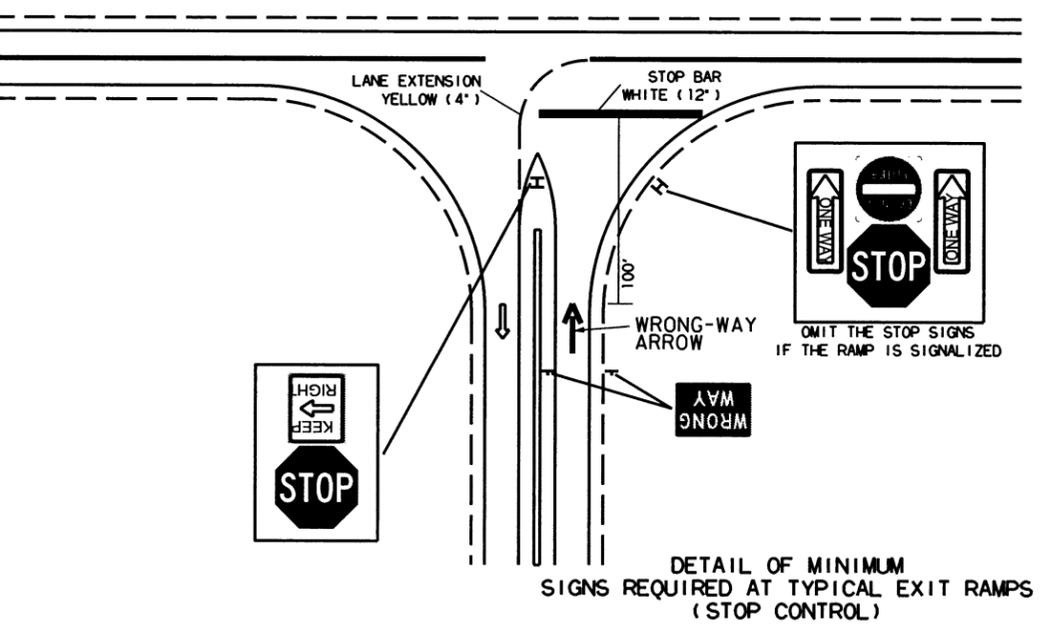

SIGN	LEGEND	SIZE	MINIMUM NUMBER REQUIRED
R1-1	STOP	36" X 36"	2
R1-2	YIELD	48" X 48" X 48"	1
R5-1	DO NOT ENTER	30" X 30"	3
R5-1A	WRONG WAY	42" X 30"	2
R6-1L	ONE WAY	36" X 12"	2
R6-1R	ONE WAY	36" X 12"	2

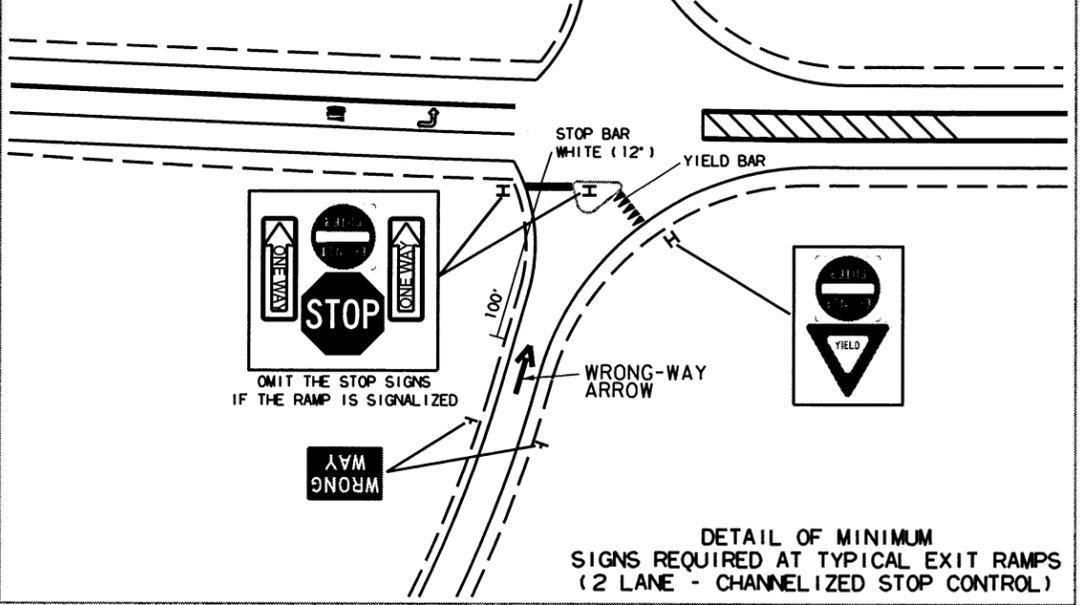

SPECIAL DETAILS

DATE REVISED	DATE FILMED	DATE REVISED	DATE FILMED	FED. DIST. NO.	STATE	FED. AID PROJ. NO.	SHEET NO.	TOTAL SHEETS
				6	ARK.			
JOB NO. 012260							5	61

2 SPECIAL DETAILS

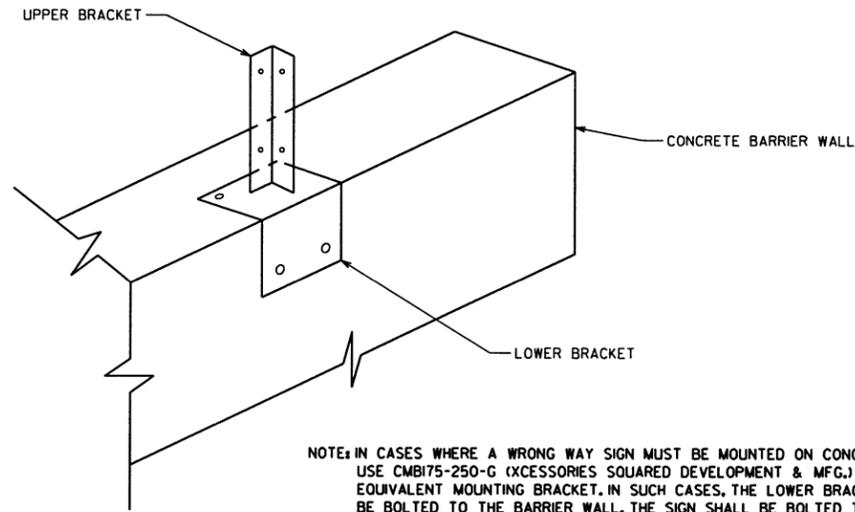

NOTE: IN CASES WHERE A WRONG WAY SIGN MUST BE MOUNTED ON CONCRETE BARRIER WALL, USE CMB175-250-G (ACCESSORIES SQUARED DEVELOPMENT & MFG.) OR APPROVED EQUIVALENT MOUNTING BRACKET. IN SUCH CASES, THE LOWER BRACKET SHALL BE BOLTED TO THE BARRIER WALL. THE SIGN SHALL BE BOLTED TO SQUARE TUBING, WHICH IS BOLTED TO THE UPPER BRACKET.

CONCRETE BARRIER MOUNT BRACKET DETAIL

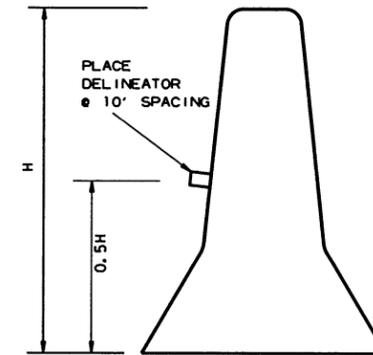

BARRIER DELINEATION DETAIL

NOTE: THE DELINEATOR COLOR SHALL BE RED FACING THE INCORRECT TRAFFIC MOVEMENT AND SHALL MATCH THE EDGE LINE FACING THE CORRECT TRAFFIC MOVEMENT.

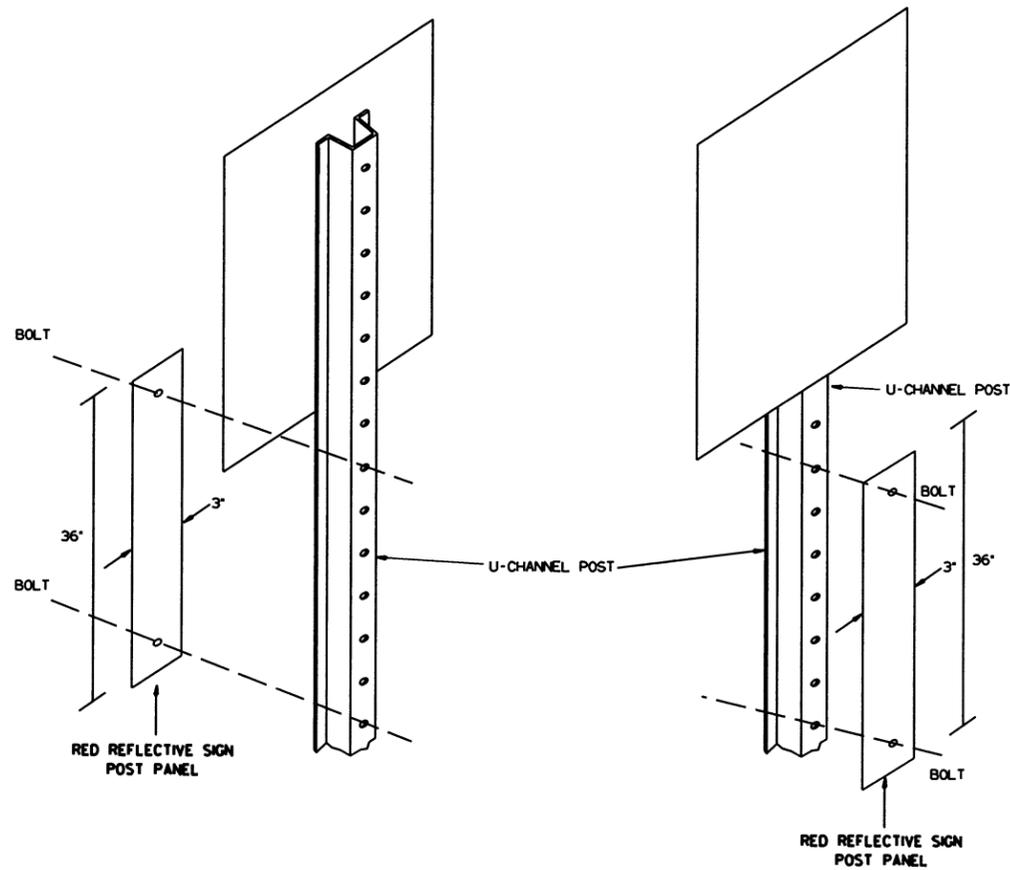

REFLECTIVE SIGN POST PANEL DETAIL

NOTE: BOLT TO SAME SIDE OF POST AS "WRONG WAY" OR "DO NOT ENTER" SIGN WITH REFLECTIVE MATERIAL FACING OUTWARD.

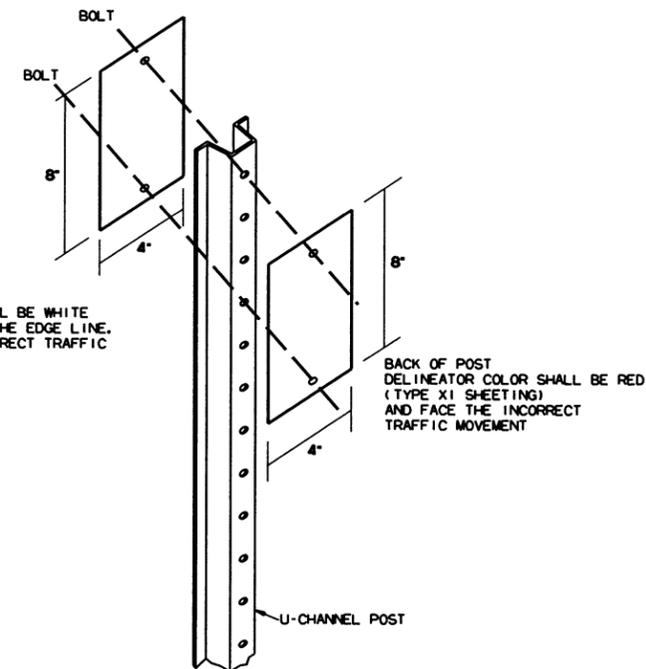

POST MOUNTED DELINEATORS

NOTE: MOUNT DELINEATORS BACK-TO-BACK WITH REFLECTIVE MATERIAL FACING OUTWARD.

SPECIAL DETAILS

9/26/16

r012260.dgn

DATE REVISED	DATE FILMED	DATE REVISED	DATE FILMED	FED. RD. DIST. NO.	STATE	FED. AID PROJ. NO.	SHEET NO.	TOTAL SHEETS
12-13-16				6	ARK.			
JOB NO. 012260							5A	61

② SPECIAL DETAILS



**LEGEND**

← DIRECTION OF TRAVEL

⊙ DELINEATOR

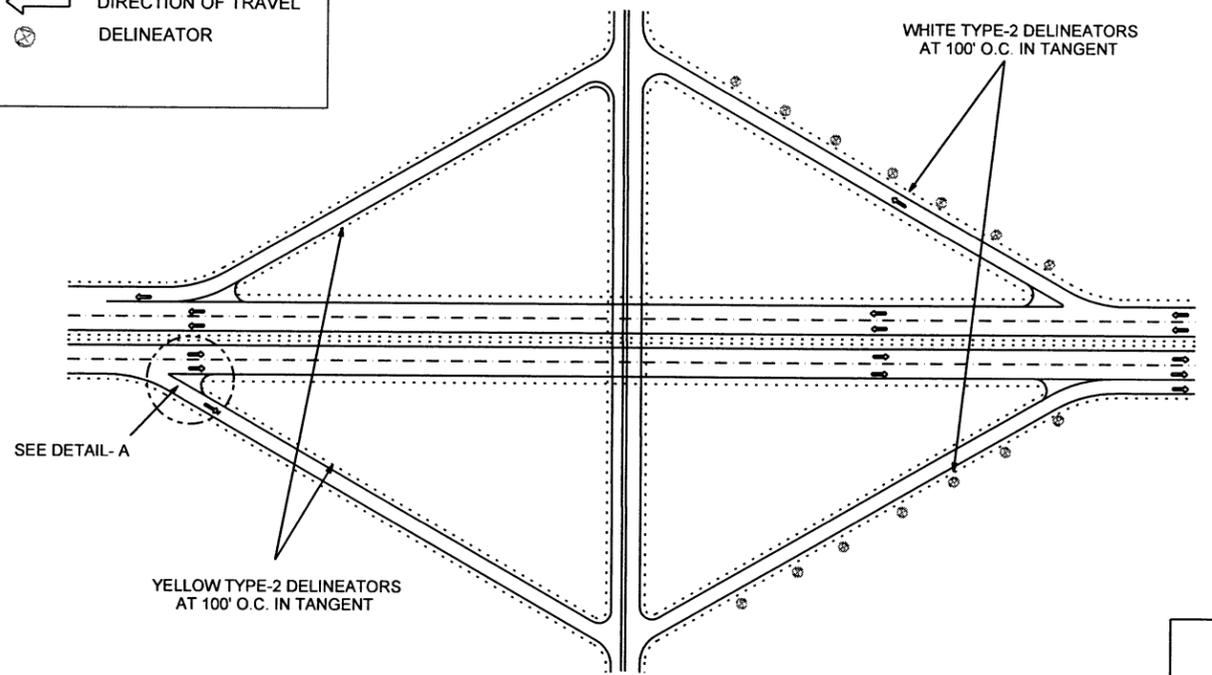

**TYPICAL DIAMOND INTERCHANGE (ALL RAMPS)**

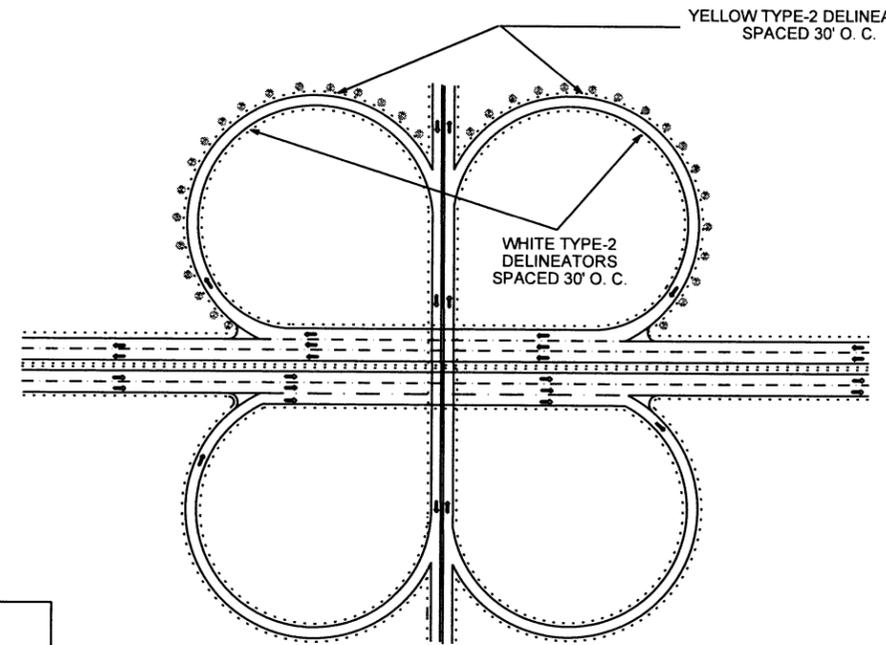

**TYPICAL CLOVERLEAF INTERCHANGE (ALL RAMPS)**

(4) TYPE-2 (WH) DELINEATORS @ 50' O. C.

(7) TYPE-2 (YEL) DELINEATORS @ 25' O. C.

**DETAIL - A**

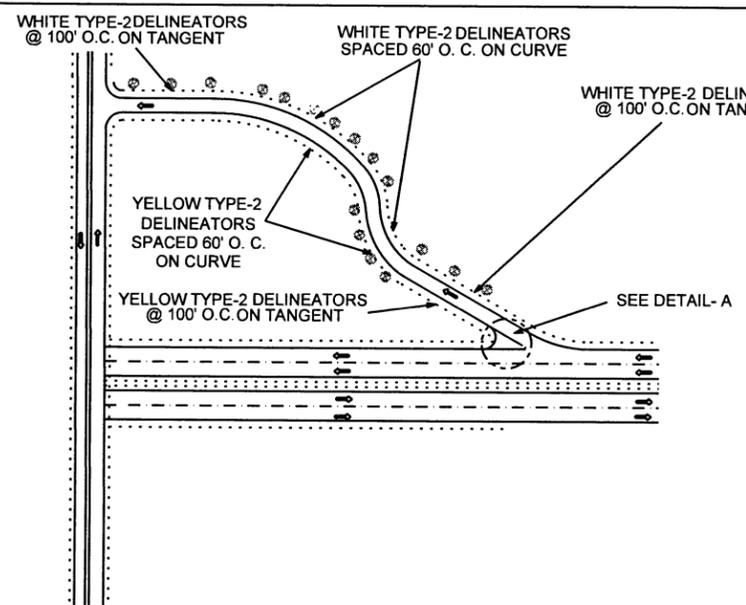

**MODIFIED DIAMOND INTERCHANGE**

**NOTE:**  
 DELINEATORS SHALL ONLY BE INSTALLED AS SHOWN IN DETAIL-A IF RAISED PAVEMENT MARKERS ARE NOT PRESENT IN THE GORE OF THE OFF RAMPS.

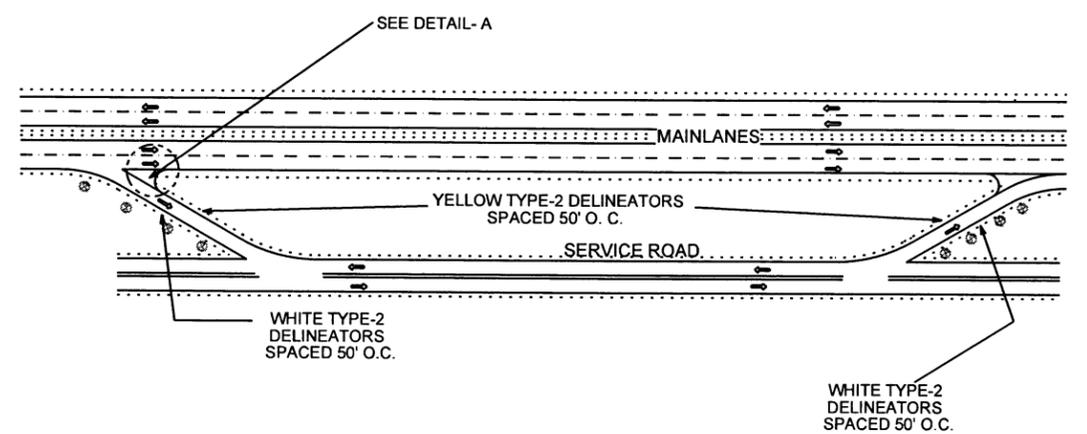

**TYPICAL SLIP RAMP**

**GUIDANCE:**  
 DELINEATORS SHOULD BE MOUNTED ON SUITABLE SUPPORTS SO THAT THE TOP OF THE HIGHEST RETROREFLECTOR IS 1.2 M (4 FT) ABOVE THE NEAR ROADWAY EDGE. THEY SHOULD BE PLACED 0.6 TO 2.4 M (2 TO 8 FT) OUTSIDE THE OUTER EDGE OF THE SHOULDER, OR IF APPROPRIATE, IN LINE WITH THE ROADSIDE BARRIER THAT IS 2.4 M (8 FT) OR LESS OUTSIDE THE OUTER EDGE OF THE SHOULDER.

ROADWAY SPECIAL DETAILS.DGN

11/18/14

DATE REVISED	DATE FILED	DATE REVISED	DATE FILED	FED. RD. DIST. NO.	STATE	FED. AID PROJ. NO.	SHEET NO.	TOTAL SHEETS
				6	ARK.			
JOB NO. 012260							6	61

② SPECIAL DETAILS

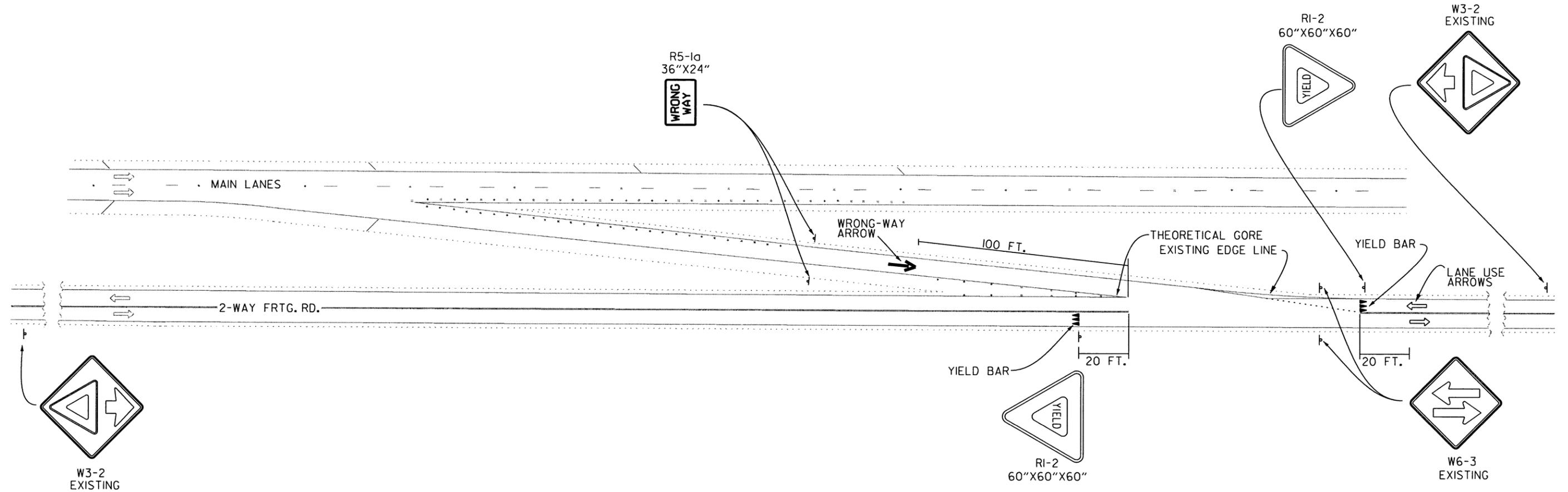

TYPICAL OFF RAMP @ TWO-WAY FRONTAGE ROADS

SPECIAL DETAILS

9/26/16

r012260.dgn

DATE REVISED	DATE FILED	DATE REVISED	DATE FILED	FED. RD. DIST. NO.	STATE	FED. AID PROJ. NO.	SHEET NO.	TOTAL SHEETS
				6	ARK.			
JOB NO.						012260	7	61

2 QUANTITIES



DISTRICT 1  
CRITTENDEN COUNTY

DISTRICT 1  
CRITTENDEN COUNTY

DISTRICT 1  
CRITTENDEN COUNTY

ROUTE	SECT.	LOG MILE (EXIT NO.) DIRECTION	SIGNS	LOCATION AND SIZE			TOTAL SIGNS	
				LEFT	RIGHT	FAR RIGHT	NO.	SQ. FT.
40	52	265 E.B.	STOP	36"	36"		2	18.00
			YIELD			48"	1	7.00
			DO NOT ENTER	30"	30"	30"	3	18.75
			ONE WAY	(2) 12"x 36"	(2) 12"x 36"		4	12.00
			WRONG WAY	30"x 42"	30"x 42"		2	17.50
			KEEP RIGHT					
40	52	265 W.B.	STOP	36"	36"		2	18.00
			YIELD			48"	1	7.00
			DO NOT ENTER	30"	30"	30"	3	18.75
			ONE WAY	(2) 12"x 36"	(2) 12"x 36"		4	12.00
			WRONG WAY	30"x 42"	30"x 42"		2	17.50
			KEEP RIGHT					
40	52	271 E.B. (SLIP RAMP)	STOP				2	14.00
			YIELD	* 48"	* 48"		2	14.00
			DO NOT ENTER	30"	30"		2	12.50
			ONE WAY					
			WRONG WAY					
			KEEP RIGHT					
40	52	271 W.B.	STOP			48"	2	14.00
			YIELD	* 48"		30"	3	18.75
			DO NOT ENTER	* 30"	30"		2	6.00
			ONE WAY	12"x 36"	12"x 36"		2	6.00
			WRONG WAY	30"x 42"	30"x 42"		2	17.50
			KEEP RIGHT	* 24"x 30"			1	5.00
40	52	275 E.B.	STOP	48"	48"		2	32.00
			YIELD			48"	1	7.00
			DO NOT ENTER	36"	36"	36"	3	27.00
			ONE WAY		(2) 18"x 54"		2	13.50
			WRONG WAY	30"x 42"	30"x 42"		2	17.50
			KEEP RIGHT					
40	52	275 W.B.	STOP	48"	48"		2	32.00
			YIELD			48"	1	7.00
			DO NOT ENTER	36"	36"	36"	3	27.00
			ONE WAY		(2) 18"x 54"		2	13.50
			WRONG WAY	30"x 42"	30"x 42"		2	17.50
			KEEP RIGHT					
<b>SUBTOTAL:</b>							<b>428.25</b>	

\* ON INTERSECTING ROADWAY  
ON ALL SLIP RAMPS TO TWO-WAY FRONTAGE ROADS, (2) 48" W6-3  
SIGNS ARE REQUIRED ON THE FRONTAGE ROAD JUST BEYOND THE RAMP.

ROUTE	SECT.	LOG MILE (EXIT NO.) DIRECTION	SIGNS	LOCATION AND SIZE			TOTAL SIGNS	
				LEFT	RIGHT	FAR RIGHT	NO.	SQ. FT.
40	52	280 E.B.	STOP	48"	48"		2	32.00
			YIELD			48"	1	7.00
			DO NOT ENTER	30"	30"	30"	3	18.75
			ONE WAY	(2) 18"x 54"	(2) 18"x 54"		4	27.00
			WRONG WAY	30"x 42"	30"x 42"		2	17.50
			KEEP RIGHT					
40	52	280 W.B.	STOP	48"	48"		2	32.00
			YIELD			48"	1	7.00
			DO NOT ENTER	30"	30"	30"	3	18.75
			ONE WAY	(2) 18"x 54"	(2) 18"x 54"		4	27.00
			WRONG WAY	30"x 42"	30"x 42"		2	17.50
			KEEP RIGHT					
40	52	281 W.B.	STOP	36"	36"		2	18.00
			YIELD			48"	1	7.00
			DO NOT ENTER	30"	30"	30"	3	18.75
			ONE WAY	(2) 12"x 36"	(2) 12"x 36"		4	12.00
			WRONG WAY	30"x 42"	30"x 42"		2	17.50
			KEEP RIGHT					
55	11	1 N.B.	STOP	36"	36"		2	18.00
			YIELD					
			DO NOT ENTER		36"		1	9.00
			ONE WAY		(2) 12"x 36"		2	6.00
			WRONG WAY	30"x 42"	30"x 42"		2	17.50
			KEEP RIGHT	24"x 30"			1	5.00
55	11	1 S.B.	STOP	36"	36"		2	18.00
			YIELD					
			DO NOT ENTER		36"		1	9.00
			ONE WAY		(2) 12"x 36"		2	6.00
			WRONG WAY	30"x 42"	30"x 42"		2	17.50
			KEEP RIGHT	24"x 30"			1	5.00
55	11	3A N.B.	STOP	48"	48"		2	32.00
			YIELD			48"	1	7.00
			DO NOT ENTER	36"	36"	30"	2/1	24.25
			ONE WAY	(2) 18"x 54"	(2) 18"x 54"		4	27.00
			WRONG WAY	30"x 42"	30"x 42"		2	17.50
			KEEP RIGHT					
<b>SUBTOTAL:</b>							<b>496.50</b>	

\* ON INTERSECTING ROADWAY  
ON ALL SLIP RAMPS TO TWO-WAY FRONTAGE ROADS, (2) 48" W6-3  
SIGNS ARE REQUIRED ON THE FRONTAGE ROAD JUST BEYOND THE RAMP.

ROUTE	SECT.	LOG MILE (EXIT NO.) DIRECTION	SIGNS	LOCATION AND SIZE			TOTAL SIGNS	
				LEFT	RIGHT	FAR RIGHT	NO.	SQ. FT.
55	11	4 N.B.	STOP	48"	48"		2	32.00
			YIELD			48"	1	7.00
			DO NOT ENTER	36"	36"	30"	2/1	24.25
			ONE WAY	(2) 18"x 54"	(2) 18"x 54"		4	27.00
			WRONG WAY	30"x 42"	30"x 42"		2	17.50
			KEEP RIGHT					
55	11	4 S.B.	STOP	48"	48"		2	32.00
			YIELD			48"	1	7.00
			DO NOT ENTER	36"	36"	30"	2/1	24.25
			ONE WAY	(2) 18"x 54"	(2) 18"x 54"		4	27.00
			WRONG WAY	30"x 42"	30"x 42"		2	17.50
			KEEP RIGHT					
55	11	7 S.B.	STOP	36"	36"		2	18.00
			YIELD			48"	1	7.00
			DO NOT ENTER	30"	30"	30"	3	18.75
			ONE WAY	(2) 12"x 36"	(2) 12"x 36"		4	12.00
			WRONG WAY	30"x 42"	30"x 42"		2	17.50
			KEEP RIGHT					
55	11	10 N.B. (SLIP RAMP)	STOP				2	14.00
			YIELD	* 48"	* 48"		2	14.00
			DO NOT ENTER	48"	48"		2	32.00
			ONE WAY					
			WRONG WAY	30"x 42"	30"x 42"		2	17.50
			KEEP RIGHT					
55	11	10 S.B. (SLIP RAMP)	STOP				2	14.00
			YIELD	* 48"	* 48"		2	14.00
			DO NOT ENTER	48"	48"		2	32.00
			ONE WAY					
			WRONG WAY	30"x 42"	30"x 42"		2	17.50
			KEEP RIGHT					
55	11	14 N.B. (SLIP RAMP)	STOP				2	14.00
			YIELD	* 48"	* 48"		2	14.00
			DO NOT ENTER	48"	48"		2	32.00
			ONE WAY					
			WRONG WAY	30"x 42"	30"x 42"		2	17.50
			KEEP RIGHT					
<b>SUBTOTAL:</b>							<b>479.25</b>	

NOTE: RED VERTICAL STRIPS SHALL BE PLACED ON ALL WRONG-WAY & DO NOT ENTER SIGN POSTS.

DATE REVISED	DATE FILED	DATE REVISED	DATE FILED	FED. RD. DIST. NO.	STATE	FED. AID PROJ. NO.	SHEET NO.	TOTAL SHEETS
				6	ARK.			
						JOB NO. 012260	8	61

② QUANTITIES



DISTRICT 1  
CRITTENDEN COUNTY

ROUTE	SECT.	LOG MILE (EXIT NO.) DIRECTION	SIGNS	LOCATION AND SIZE			TOTAL SIGNS	
				LEFT	RIGHT	FAR RIGHT	NO.	SQ. FT.
55	11	14 S.B. (SLIP RAMP)	STOP					
			YIELD	* 48"	* 48"		2	14.00
			DO NOT ENTER	48"	48"		2	32.00
			ONE WAY					
			WRONG WAY	30"x 42"	30"x 42"		2	17.50
			KEEP RIGHT					
55	11	17 N.B. (SLIP RAMP)	STOP					
			YIELD	* 48"	* 48"		2	14.00
			DO NOT ENTER	48"	48"		2	32.00
			ONE WAY					
			WRONG WAY	30"x 42"	30"x 42"		2	17.50
			KEEP RIGHT					
55	11	17 S.B. (SLIP RAMP)	STOP					
			YIELD	* 48"	* 48"		2	14.00
			DO NOT ENTER	48"	48"		2	32.00
			ONE WAY					
			WRONG WAY	30"x 42"	30"x 42"		2	17.50
			KEEP RIGHT					
55	11	21 N.B. (SLIP RAMP)	STOP					
			YIELD	* 48"	* 48"		2	14.00
			DO NOT ENTER	48"	48"		2	32.00
			ONE WAY					
			WRONG WAY	30"x 42"	30"x 42"		2	17.50
			KEEP RIGHT					
55	11	21 S.B. (SLIP RAMP)	STOP					
			YIELD	* 48"	* 48"		2	14.00
			DO NOT ENTER	48"	48"		2	32.00
			ONE WAY					
			WRONG WAY	30"x 42"	30"x 42"		2	17.50
			KEEP RIGHT					
55	11	23B N.B. (HWY. 77 INT.)	STOP					
			YIELD	48"	48"		2	14.00
			DO NOT ENTER	30"	30"		2	12.50
			ONE WAY	(2) 12"x 36"	(2) 12"x 36"		4	12.00
			WRONG WAY	30"x 42"	30"x 42"		2	17.50
			KEEP RIGHT					
<b>SUBTOTAL:</b>							<b>373.50</b>	

\* ON INTERSECTING ROADWAY  
ON ALL SLIP RAMPS TO TWO-WAY FRONTAGE ROADS, (2) 48" W6-3  
SIGNS ARE REQUIRED ON THE FRONTAGE ROAD JUST BEYOND THE RAMP.

DISTRICT 1  
CRITTENDEN COUNTY

ROUTE	SECT.	LOG MILE (EXIT NO.) DIRECTION	SIGNS	LOCATION AND SIZE			TOTAL SIGNS	
				LEFT	RIGHT	FAR RIGHT	NO.	SQ. FT.
55	11	23B S.B.	STOP					
			YIELD		48"		1	7.00
			DO NOT ENTER	48"	30"		1/1	22.25
			ONE WAY					
			WRONG WAY	30"x 42"	30"x 42"		2	17.50
			KEEP RIGHT					
555	1	2 N.B.	STOP	36"	36"		2	18.00
			YIELD			48"	1	7.00
			DO NOT ENTER	30"	30"	30"	3	18.75
			ONE WAY	(2) 12"x 36"	(2) 12"x 36"		4	12.00
			WRONG WAY	30"x 42"	30"x 42"		2	17.50
			KEEP RIGHT					
555	1	2 S.B.	STOP	36"	36"		2	18.00
			YIELD			48"	1	7.00
			DO NOT ENTER	30"	30"	30"	3	18.75
			ONE WAY	(2) 12"x 36"	(2) 12"x 36"		4	12.00
			WRONG WAY	30"x 42"	30"x 42"		2	17.50
			KEEP RIGHT					
			STOP					
			YIELD					
			DO NOT ENTER					
			ONE WAY					
			WRONG WAY					
			KEEP RIGHT					
			STOP					
			YIELD					
			DO NOT ENTER					
			ONE WAY					
			WRONG WAY					
			KEEP RIGHT					
			STOP					
			YIELD					
			DO NOT ENTER					
			ONE WAY					
			WRONG WAY					
			KEEP RIGHT					
<b>SUBTOTAL:</b>							<b>193.25</b>	
<b>TOTAL CRITTENDEN COUNTY:</b>							<b>1970.75</b>	

DISTRICT 1  
MONROE COUNTY

ROUTE	SECT.	LOG MILE (EXIT NO.) DIRECTION	SIGNS	LOCATION AND SIZE			TOTAL SIGNS	
				LEFT	RIGHT	FAR RIGHT	NO.	SQ. FT.
40	43	216 E.B.	STOP					
			YIELD			48"	1	7.00
			DO NOT ENTER		36"	30"	1/1	15.25
			ONE WAY	54"x 18"	54"x 18"		2	
			WRONG WAY	30"x 42"	30"x 42"		2	
			KEEP RIGHT	24"x 30"			1	
40	43	216 W.B.	STOP	48"	48"		2	32.00
			YIELD			48"	1	7.00
			DO NOT ENTER		36"	30"	1/1	15.25
			ONE WAY	54"x 18"	54"x 18"		2	13.50
			WRONG WAY	30"x 42"	30"x 42"		2	17.50
			KEEP RIGHT	24"x 30"			1	5.00
			STOP					
			YIELD					
			DO NOT ENTER					
			ONE WAY					
			WRONG WAY					
			KEEP RIGHT					
			STOP					
			YIELD					
			DO NOT ENTER					
			ONE WAY					
			WRONG WAY					
			KEEP RIGHT					
			STOP					
			YIELD					
			DO NOT ENTER					
			ONE WAY					
			WRONG WAY					
			KEEP RIGHT					
<b>TOTAL MONROE COUNTY:</b>							<b>112.50</b>	

NOTE: RED VERTICAL STRIPS SHALL BE PLACED ON ALL WRONG-WAY & DO NOT ENTER SIGN POSTS.

DATE REVISED	DATE FILMED	DATE REVISED	DATE FILMED	FED. RD. DIST. NO.	STATE	FED. AID PROJ. NO.	SHEET NO.	TOTAL SHEETS
				6	ARK.			
						JOB NO. 012260	9	61

② QUANTITIES



DISTRICT 1  
ST. FRANCIS COUNTY

ROUTE	SECT.	LOG MILE (EXIT NO.) DIRECTION	SIGNS	LOCATION AND SIZE			TOTAL SIGNS	
				LEFT	RIGHT	FAR RIGHT	NO.	SQ. FT.
40	51	221 E.B.	STOP	36"	36"		2	18.00
			YIELD			48"	1	7.00
			DO NOT ENTER	30"	30"	30"	3	18.75
			ONE WAY	(2) 12"x 36"	(2) 12"x 36"		4	12.00
			WRONG WAY	30"x 42"	30"x 42"		2	17.50
			KEEP RIGHT					
40	51	221 W.B.	STOP	36"	36"		2	18.00
			YIELD			48"	1	7.00
			DO NOT ENTER	30"	30"	30"	3	18.75
			ONE WAY	(2) 12"x 36"	(2) 12"x 36"		4	12.00
			WRONG WAY	30"x 42"	30"x 42"		2	17.50
			KEEP RIGHT					
40	51	233 E.B.	STOP	36"	36"		2	18.00
			YIELD			48"	1	7.00
			DO NOT ENTER	30"	30"	30"	3	18.75
			ONE WAY	(2) 12"x 36"	(2) 12"x 36"		4	12.00
			WRONG WAY	30"x 42"	30"x 42"		2	17.50
			KEEP RIGHT					
40	51	233 W.B.	STOP	36"	36"		2	18.00
			YIELD			48"	1	7.00
			DO NOT ENTER	30"	30"	30"	3	18.75
			ONE WAY	(2) 12"x 36"	(2) 12"x 36"		4	12.00
			WRONG WAY	30"x 42"	30"x 42"		2	17.50
			KEEP RIGHT					
40	51	239 E.B.	STOP	36"	36"		2	18.00
			YIELD			48"	1	7.00
			DO NOT ENTER	30"	30"	30"	3	18.75
			ONE WAY	(2) 12"x 36"	(2) 12"x 36"		4	12.00
			WRONG WAY	30"x 42"	30"x 42"		2	17.50
			KEEP RIGHT					
40	51	239 W.B.	STOP	36"	36"		2	18.00
			YIELD			48"	1	7.00
			DO NOT ENTER	30"	30"	30"	3	18.75
			ONE WAY	(2) 12"x 36"	(2) 12"x 36"		4	12.00
			WRONG WAY	30"x 42"	30"x 42"		2	17.50
			KEEP RIGHT					
<b>SUBTOTAL:</b>							<b>413.00</b>	

DISTRICT 1  
ST. FRANCIS COUNTY

ROUTE	SECT.	LOG MILE (EXIT NO.) DIRECTION	SIGNS	LOCATION AND SIZE			TOTAL SIGNS	
				LEFT	RIGHT	FAR RIGHT	NO.	SQ. FT.
40	51	241A E.B.	STOP					
			YIELD		48"		1	7.00
			DO NOT ENTER	36"	36"		2	18.00
			ONE WAY					
			WRONG WAY	30"x 42"	30"x 42"		2	17.50
			KEEP RIGHT					
40	51	241A W.B.	STOP					
			YIELD		48"		1	7.00
			DO NOT ENTER	36"	36"		2	18.00
			ONE WAY					
			WRONG WAY	30"x 42"	30"x 42"		2	17.50
			KEEP RIGHT					
40	51	241B W.B.	STOP					
			YIELD		48"		1	7.00
			DO NOT ENTER	36"	36"		2	18.00
			ONE WAY					
			WRONG WAY	30"x 42"	30"x 42"		2	17.50
			KEEP RIGHT					
40	51	242 E.B.	STOP	36"	36"		2	18.00
			YIELD			48"	1	7.00
			DO NOT ENTER	30"	30"	30"	3	18.75
			ONE WAY	(2) 12"x 36"	(2) 12"x 36"		4	12.00
			WRONG WAY	30"x 42"	30"x 42"		2	17.50
			KEEP RIGHT					
40	51	242 W.B.	STOP	36"	36"		2	18.00
			YIELD			48"	1	7.00
			DO NOT ENTER	30"	30"	30"	3	18.75
			ONE WAY	(2) 12"x 36"	(2) 12"x 36"		4	12.00
			WRONG WAY	30"x 42"	30"x 42"		2	17.50
			KEEP RIGHT					
40	51	247 E.B.	STOP	36"	36"		2	18.00
			YIELD			48"	1	7.00
			DO NOT ENTER	30"	30"	30"	3	18.75
			ONE WAY	(2) 12"x 36"	(2) 12"x 36"		4	12.00
			WRONG WAY	30"x 42"	30"x 42"		2	17.50
			KEEP RIGHT					
<b>SUBTOTAL:</b>							<b>347.25</b>	

DISTRICT 1  
ST. FRANCIS COUNTY

ROUTE	SECT.	LOG MILE (EXIT NO.) DIRECTION	SIGNS	LOCATION AND SIZE			TOTAL SIGNS	
				LEFT	RIGHT	FAR RIGHT	NO.	SQ. FT.
40	51	247 W.B.	STOP	36"	36"		2	18.00
			YIELD			48"	1	7.00
			DO NOT ENTER	30"	30"	30"	3	18.75
			ONE WAY	(2) 12"x 36"	(2) 12"x 36"		4	12.00
			WRONG WAY	30"x 42"	30"x 42"		2	17.50
			KEEP RIGHT					
40	51	256 E.B.	STOP	36"	36"		2	18.00
			YIELD			48"	1	7.00
			DO NOT ENTER	30"	30"	30"	3	18.75
			ONE WAY	(2) 12"x 36"	(2) 12"x 36"		4	12.00
			WRONG WAY	30"x 42"	30"x 42"		2	17.50
			KEEP RIGHT					
40	51	260 E.B.	STOP	48"	48"		2	32.00
			YIELD			48"	1	7.00
			DO NOT ENTER		36"	36"	2	18.00
			ONE WAY		(2) 18"x 54"		2	13.50
			WRONG WAY	30"x 42"	30"x 42"		2	17.50
			KEEP RIGHT	24"x 30"			1	5.00
40	51	260 W.B.	STOP	48"	48"		2	32.00
			YIELD			48"	1	7.00
			DO NOT ENTER		36"	30"	1/1	15.25
			ONE WAY		(2) 18"x 54"		2	13.50
			WRONG WAY	30"x 42"	30"x 42"		2	17.50
			KEEP RIGHT	24"x 30"			1	5.00
<b>SUBTOTAL:</b>							<b>329.75</b>	
<b>TOTAL ST. FRANCIS COUNTY:</b>							<b>1090.00</b>	
<b>TOTAL DISTRICT 1:</b>							<b>3173.25</b>	

NOTE: RED VERTICAL STRIPS SHALL BE PLACED ON ALL WRONG-WAY & DO NOT ENTER SIGN POSTS.

DATE REVISED	DATE FILMED	DATE REVISED	DATE FILMED	FED. PROJ. NO.	STATE	FED. PROJ. NO.	SHEET NO.	TOTAL SHEETS
12/13/16				6	ARK.			
						JOB NO.	012260	10 61

2 QUANTITIES



STOP LINES, WRONG-WAY ARROWS, AND RAMP DELINEATORS

DISTRICT	COUNTY	ROUTE	MAINLANE SECTION	RAMP SECTION	EXIT NUMBER	CROSS ROAD	STOP LINES	YIELD LINES	THERMO. WRONG-WAY PAVEMENT ARROWS	DELINEATOR (TYPE 2) YELLOW	DELINEATOR (TYPE 2) WHITE	TYPE OF RAMP
							LIN. FT.	LIN. FT.	EACH	EACH	EACH	
1	CRITTENDEN	40	52	713	265	79/218	15	15	1	18	25	MODIFIED DIAMOND
1	CRITTENDEN	40	52	717	265	79/218	15	15	1	20	25	MODIFIED DIAMOND
1	CRITTENDEN	40	52	723	271	147		24	1	16	17	SLIP
1	CRITTENDEN	40	52	725	271	147		44	1	19	21	TYPICAL DIAMOND
1	CRITTENDEN	40	52	729	N/A	LEHI WEIGH STA.			1	7	33	TYPICAL DIAMOND
1	CRITTENDEN	40	52	732	N/A	LEHI WEIGH STA.			1	5	10	TYPICAL DIAMOND
1	CRITTENDEN	40	52	736	275	118	14	17	1	27	41	MODIFIED DIAMOND
1	CRITTENDEN	40	52	739	275	118	14	15	1	27	50	MODIFIED DIAMOND
1	CRITTENDEN	40	52	744	276	N/A	17	22	1	13	24	MODIFIED DIAMOND
1	CRITTENDEN	40	52	751	278	191			1	7	12	SLIP
1	CRITTENDEN	40	52	755	279A EB	THOMAS AVE.			1	7	9	SLIP
1	CRITTENDEN	40	52	758	5	THOMAS AVE.			1	5	8	SLIP
1	CRITTENDEN	40	52	761	280	38	23	24	1	13	16	TYPICAL DIAMOND
1	CRITTENDEN	40	52	765	280	38	22	40	1	11	10	TYPICAL DIAMOND
1	CRITTENDEN	40	52	772	281	131	20	16	1	12	15	TYPICAL DIAMOND
1	CRITTENDEN	40	52	841	N/A	TRUCK PARKING			1	7	11	TYPICAL DIAMOND
1	CRITTENDEN	40	52	843	N/A	I-40 MISS. RIV. WEIGH STATION			1	14	29	TYPICAL DIAMOND
1	CRITTENDEN	40	52	886	278	191			1	7	9	SLIP
1	CRITTENDEN	40	52	N/A	279A WB	FRONTAGE ROAD			1	26	27	SLIP
1	CRITTENDEN	55	11	111	1	BRIDGEPORT RD.	31		1	22	25	MODIFIED DIAMOND
1	CRITTENDEN	55	11	113	1	BRIDGEPORT RD.	45		1	26	35	LOOP
1	CRITTENDEN	55	11	127	3A	NORTH FRONTAGE ROAD	20	22	1	10	14	TYPICAL DIAMOND
1	CRITTENDEN	55	11	133	4	38	17	15	1	24	32	MODIFIED DIAMOND
1	CRITTENDEN	55	11	136	4	38	23	19	1	26	34	MODIFIED DIAMOND
1	CRITTENDEN	55	11	144	N/A	MARION WEIGH STA.			1	7	9	TYPICAL DIAMOND
1	CRITTENDEN	55	11	146	N/A	MARION WEIGH STA.			1	7	9	TYPICAL DIAMOND
1	CRITTENDEN	55	11	148	10	64			1	5	10	SLIP
1	CRITTENDEN	55	11	152	10	64			1	5	10	SLIP
1	CRITTENDEN	55	11	153	14	E. JAMES MILL RD.			1	5	8	SLIP
1	CRITTENDEN	55	11	155	14	E. JAMES MILL RD.			1	5	10	SLIP
1	CRITTENDEN	55	11	177	17	50			1	5	10	SLIP
1	CRITTENDEN	55	11	191	21	42			1	5	10	SLIP
1	CRITTENDEN	55	11	193	21	42			1	7	10	SLIP
1	CRITTENDEN	55	11	207	23	77		17	1	36	47	TYPICAL DIAMOND
1	CRITTENDEN	55	11	211	23	63		14	1	38	46	LOOP
1	CRITTENDEN	55	11	344	7	SOUTH FRONTAGE ROAD	21	24	1	13	17	MODIFIED DIAMOND
1	CRITTENDEN	55	11	352	17	50			1	7	9	SLIP
1	CRITTENDEN	55	11	357	N/A	WEST MEMPHIS WEIGH STATION			1	8	17	TYPICAL DIAMOND
1	CRITTENDEN	555	1	115	2	28	17	18	1	16	25	TYPICAL DIAMOND
1	CRITTENDEN	555	1	119	2	28	16	18	1	25	30	TYPICAL DIAMOND
SUBTOTALS CRITTENDEN COUNTY:							330	379	40	563	809	
1	MONROE	40	43	624	216	49	47	15	1	19	19	MODIFIED DIAMOND
1	MONROE	40	43	626	216	49	15	15	1	18	18	MODIFIED DIAMOND
SUBTOTALS MONROE COUNTY:							62	30	2	37	37	
1	ST. FRANCIS	40	51	631	221	78	20	22	1	24	24	MODIFIED DIAMOND
1	ST. FRANCIS	40	51	634	221	78	20	23	1	26	26	MODIFIED DIAMOND
1	ST. FRANCIS	40	51	643	233	261	58		1	24	24	MODIFIED DIAMOND
1	ST. FRANCIS	40	51	645	233	261	58		1	23	23	MODIFIED DIAMOND
1	ST. FRANCIS	40	51	651	239	1	24	20	1	22	22	MODIFIED DIAMOND
1	ST. FRANCIS	40	51	655	239	1	26	20	1	22	22	MODIFIED DIAMOND
1	ST. FRANCIS	40	51	659	241A	1B			1	25	25	TYPICAL DIAMOND
1	ST. FRANCIS	40	51	663	241B	1B			1	33	33	LOOP
1	ST. FRANCIS	40	51	667	241A	1B			1	28	28	LOOP
1	ST. FRANCIS	40	51	664	241B	1B			1	29	29	TYPICAL DIAMOND
1	ST. FRANCIS	40	51	668	242	284	38	22	1	20	20	TYPICAL DIAMOND
1	ST. FRANCIS	40	51	673	242	284	33	21	1	12	12	TYPICAL DIAMOND
1	ST. FRANCIS	40	51	682	247	38	44	19	1	20	20	MODIFIED DIAMOND
1	ST. FRANCIS	40	51	685	247	38	40	18	1	19	19	MODIFIED DIAMOND
1	ST. FRANCIS	40	51	692	256	75	24	16	1	17	17	TYPICAL DIAMOND
1	ST. FRANCIS	40	51	696	256	75	25	16	1	17	17	TYPICAL DIAMOND
1	ST. FRANCIS	40	51	703	260	149	*	*	*	*	*	LOOP
1	ST. FRANCIS	40	51	705	260	149	*	*	*	*	*	MODIFIED DIAMOND
1	ST. FRANCIS	40	51	833	N/A	FORREST CITY REST AREA EB			1	11	11	TYPICAL DIAMOND
1	ST. FRANCIS	40	51	837	N/A	FORREST CITY REST AREA WB			1	14	14	TYPICAL DIAMOND
SUBTOTALS ST. FRANCIS COUNTY:							410	197	18	386	386	
TOTALS DISTRICT 1:							802	606	60	986	1232	

NOTE: REFER TO SHS MANUAL FOR DIMENSIONS FOR THERMOPLASTIC WRONG-WAY PAVEMENT ARROWS, THERMOPLASTIC WRONG-WAY PAVEMENT ARROWS SHALL BE PAID FOR UNDER "THERMOPLASTIC PAVEMENT MARKING (ARROWS)".  
\* THESE LOCATIONS ARE CURRENTLY UNDER CONSTRUCTION AND WRONG-WAY DRIVING COUNTERMEASURES WILL BE ADDED TO THEIR JOB SCOPE

LANE USE ARROWS

DISTRICT	COUNTY	ROUTE	SECTION	DIRECTION	EXIT NO.	LANE USE ARROWS	TO
						EACH	
1	CRITTENDEN	40	52	EB	271	2	US 70/AR 147
1	CRITTENDEN	55	11	SB	21	2	AR 42/FRONTAGE ROAD
1	CRITTENDEN	55	11	NB	21	2	AR 42/FRONTAGE ROAD
1	CRITTENDEN	55	11	SB	17	2	AR 50/FRONTAGE ROAD
1	CRITTENDEN	55	11	NB	17	2	AR 50/FRONTAGE ROAD
1	CRITTENDEN	55	11	SB	14	2	CO. RD. 4/E JAMES MILL ROAD
1	CRITTENDEN	55	11	NB	14	2	CO. RD. 4/E JAMES MILL ROAD
1	CRITTENDEN	55	11	SB	10	2	AR 64/FRONTAGE ROAD
1	CRITTENDEN	55	11	NB	10	2	AR 64/FROATAGE ROAD
TOTAL DISTRICT 1:						18	

NOTE: LANE USE ARROWS WILL BE PLACED IN A PAIR (AS SHOWN ON SHEET 6) TO SHOW THE CORRECT TRAFFIC MOVEMENT FOR VEHICLES EXITING THE FREEWAY AND VEHICLES ON THE FRONTAGE ROADS. THE CONTRACTOR SHALL PLACE THE ARROWS, ONE FOR EACH DIRECTION OF TRAVEL, ON TWO-WAY FRONTAGE ROADS DOWNSTREAM FROM A FREEWAY EXIT RAMP. SEE DETAIL ON SHEET NO. 6. LANE USE ARROWS SHALL BE PAID FOR UNDER "THERMOPLASTIC PAVEMENT MARKING (ARROWS)".

BARRIER WALL DELINEATORS

DISTRICT	COUNTY	ROUTE	SECTION	EXIT NO	CROSS ROAD	BARRIER LENGTH	NUMBER OF BARRIER WALL DELINEATORS
						LIN. FT.	EACH
1	CRITTENDEN	40	52	275	HWY. 118	166	16
1	CRITTENDEN	40	52	275	HWY. 118	207	20
TOTAL DISTRICT 1:							36

LANE EXTENSIONS

DISTRICT	COUNTY	ROUTE	MAIN LANE SECTION	RAMP SECTION	EXIT NO	CROSS ROAD	LENGTH OF LANE EXTENSION
							LIN. FT.
1	CRITTENDEN	55	11	112	1	BRIDGEPORT RD.	22
1	CRITTENDEN	55	11	113	1	BRIDGEPORT RD.	25
TOTAL CRITTENDEN COUNTY:							47
1	MONROE	40	43	625	216	49	49
1	MONROE	40	43	627	216	49	60
TOTAL MONROE COUNTY:							109
1	ST. FRANCIS	40	51	703	260	149	*
1	ST. FRANCIS	40	51	707	260	149	*
TOTAL ST. FRANCIS COUNTY:							0
TOTAL DISTRICT 1:							156

NOTE: LANE EXTENSIONS SHALL BE DASHED, 4" WIDE, YELLOW PAVEMENT MARKINGS THAT GUIDE LEFT-TURNING TRAFFIC FROM THE CROSS ROAD TO THE CORRECT RAMP AT A FREEWAY INTERCHANGE. LANE EXTENSIONS SHALL BE PAID FOR UNDER "THERMOPLASTIC PAVEMENT MARKING YELLOW (6)".  
\* THESE LOCATIONS ARE CURRENTLY UNDER CONSTRUCTION AND WRONG-WAY DRIVING COUNTERMEASURES WILL BE ADDED TO THEIR JOB SCOPE

r012260.dgn Quantities

12/8/16

DISTRICT 1 QUANTITIES

DATE REVISED	DATE FILED	DATE REVISED	DATE FILED	FED. RD. DIST. NO.	STATE	FED. AID PROJ. NO.	SHEET NO.	TOTAL SHEETS
				6	ARK.			
						JOB NO. 012260	11	61

2 QUANTITIES

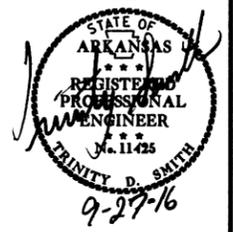

DISTRICT 2  
JEFFERSON COUNTY

ROUTE	SECT.	LOG MILE (EXIT NO.) DIRECTION	SIGNS	LOCATION AND SIZE			TOTAL SIGNS	
				LEFT	RIGHT	FAR RIGHT	NO.	SQ. FT.
530	5	20 N.B.	STOP	36"	36"		2	18.00
			YIELD			48"	1	7.00
			DO NOT ENTER	30"	30"	30"	3	18.75
			ONE WAY	(2) 12"x 36"	(2) 12"x 36"		4	12.00
			WRONG WAY	30"x 42"	30"x 42"		2	17.50
			KEEP RIGHT					
530	5	20 S.B.	STOP	36"	36"		2	18.00
			YIELD			48"	1	7.00
			DO NOT ENTER	30"	30"	30"	3	18.75
			ONE WAY	(2) 12"x 36"	(2) 12"x 36"		4	12.00
			WRONG WAY	30"x 42"	30"x 42"		2	17.50
			KEEP RIGHT					
530	5	24 N.B.	STOP	36"	36"		2	18.00
			YIELD			48"	1	7.00
			DO NOT ENTER	30"	30"	30"	3	18.75
			ONE WAY	(2) 12"x 36"	(2) 12"x 36"		4	12.00
			WRONG WAY	30"x 42"	30"x 42"		2	17.50
			KEEP RIGHT					
530	5	24 S.B.	STOP	36"	36"		2	18.00
			YIELD			48"	1	7.00
			DO NOT ENTER	30"	30"	30"	3	18.75
			ONE WAY	(2) 12"x 36"	(2) 12"x 36"		4	12.00
			WRONG WAY	30"x 42"	30"x 42"		2	17.50
			KEEP RIGHT					
530	5	27 N.B.	STOP	36"	36"		2	18.00
			YIELD			48"	1	7.00
			DO NOT ENTER	30"	30"	30"	3	18.75
			ONE WAY	(2) 12"x 36"	(2) 12"x 36"		4	12.00
			WRONG WAY	30"x 42"	30"x 42"		2	17.50
			KEEP RIGHT					
530	5	27 S.B.	STOP	36"	36"		2	18.00
			YIELD			48"	1	7.00
			DO NOT ENTER	30"	30"	30"	3	18.75
			ONE WAY	(2) 12"x 36"	(2) 12"x 36"		4	12.00
			WRONG WAY	30"x 42"	30"x 42"		2	17.50
			KEEP RIGHT					
SUBTOTAL:							439.50	

DISTRICT 2  
JEFFERSON COUNTY

ROUTE	SECT.	LOG MILE (EXIT NO.) DIRECTION	SIGNS	LOCATION AND SIZE			TOTAL SIGNS	
				LEFT	RIGHT	FAR RIGHT	NO.	SQ. FT.
530	5	30 N.B.	STOP	36"	36"		2	18.00
			YIELD			48"	1	7.00
			DO NOT ENTER	30"	30"	30"	3	18.75
			ONE WAY	(2) 12"x 36"	(2) 12"x 36"		4	12.00
			WRONG WAY	30"x 42"	30"x 42"		2	17.50
			KEEP RIGHT					
530	5	30 S.B.	STOP	36"	36"		2	18.00
			YIELD			48"	1	7.00
			DO NOT ENTER	30"	30"	30"	3	18.75
			ONE WAY	(2) 12"x 36"	(2) 12"x 36"		4	12.00
			WRONG WAY	30"x 42"	30"x 42"		2	17.50
			KEEP RIGHT					
530	5	32 N.B.	STOP	36"	36"		2	18.00
			YIELD			48"	1	7.00
			DO NOT ENTER	30"	30"	30"	3	18.75
			ONE WAY	(2) 12"x 36"	(2) 12"x 36"		4	12.00
			WRONG WAY	30"x 42"	30"x 42"		2	17.50
			KEEP RIGHT					
530	5	32 S.B.	STOP	36"	36"		2	18.00
			YIELD			48"	1	7.00
			DO NOT ENTER	30"	30"	30"	3	18.75
			ONE WAY	(2) 12"x 36"	(2) 12"x 36"		4	12.00
			WRONG WAY	30"x 42"	30"x 42"		2	17.50
			KEEP RIGHT					
530	5	34 N.B.	STOP					
			YIELD			48"	1	7.00
			DO NOT ENTER	30"	30"	30"	3	18.75
			ONE WAY	(2) 12"x 36"	(2) 12"x 36"		4	12.00
			WRONG WAY	30"x 42"	30"x 42"		2	17.50
			KEEP RIGHT					
530	5	34 S.B.	STOP					
			YIELD			48"	1	7.00
			DO NOT ENTER	30"	30"	30"	3	18.75
			ONE WAY	(2) 12"x 36"	(2) 12"x 36"		4	12.00
			WRONG WAY	30"x 42"	30"x 42"		2	17.50
			KEEP RIGHT					
SUBTOTAL:							403.50	

DISTRICT 2  
JEFFERSON COUNTY

ROUTE	SECT.	LOG MILE (EXIT NO.) DIRECTION	SIGNS	LOCATION AND SIZE			TOTAL SIGNS	
				LEFT	RIGHT	FAR RIGHT	NO.	SQ. FT.
530	5	36 N.B.	STOP	36"	36"		2	18.00
			YIELD			48"	1	7.00
			DO NOT ENTER	30"	30"	30"	3	18.75
			ONE WAY	(2) 12"x 36"	(2) 12"x 36"		4	12.00
			WRONG WAY	30"x 42"	30"x 42"		2	17.50
			KEEP RIGHT					
530	5	36 S.B.	STOP	36"	36"		2	18.00
			YIELD			48"	1	7.00
			DO NOT ENTER	30"	30"	30"	3	18.75
			ONE WAY	(2) 12"x 36"	(2) 12"x 36"		4	12.00
			WRONG WAY	30"x 42"	30"x 42"		2	17.50
			KEEP RIGHT					
530	5	37 N.B.	STOP	36"	36"		2	18.00
			YIELD					
			DO NOT ENTER	30"	30"		2	12.50
			ONE WAY	(2) 12"x 36"	(2) 12"x 36"		4	12.00
			WRONG WAY	30"x 42"	30"x 42"		2	17.50
			KEEP RIGHT					
530	5	37 S.B.	STOP	36"	36"		2	18.00
			YIELD					
			DO NOT ENTER	30"	30"		2	12.50
			ONE WAY	(2) 12"x 36"	(2) 12"x 36"		4	12.00
			WRONG WAY	30"x 42"	30"x 42"		2	17.50
			KEEP RIGHT					
530	5	39 N.B.	STOP					
			YIELD			48"	1	7.00
			DO NOT ENTER	36"	36"	30"	2/1	24.25
			ONE WAY	(2) 18"x 54"	(2) 18"x 54"		4	12.00
			WRONG WAY	30"x 42"	30"x 42"		2	17.50
			KEEP RIGHT					
530	5	39 S.B.	STOP					
			YIELD			48"	1	7.00
			DO NOT ENTER	36"	36"	30"	2/1	24.25
			ONE WAY	(2) 18"x 54"	(2) 18"x 54"		4	12.00
			WRONG WAY	30"x 42"	30"x 42"		2	17.50
			KEEP RIGHT					
SUBTOTAL:							388.00	

NOTE: RED VERTICAL STRIPS SHALL BE PLACED ON ALL WRONG-WAY & DO NOT ENTER SIGN POSTS.

DATE REVISED	DATE FILMED	DATE REVISED	DATE FILMED	FED. RD. DIST. NO.	STATE	FED. AID PROJ. NO.	SHEET NO.	TOTAL SHEETS
12/13/16				6	ARK.			
							JOB NO.	012260
							SHEET NO.	12
							TOTAL SHEETS	61

② QUANTITIES



DISTRICT 2  
JEFFERSON COUNTY

ROUTE	SECT.	LOG MILE (EXIT NO.) DIRECTION	SIGNS	LOCATION AND SIZE			TOTAL SIGNS	
				LEFT	RIGHT	FAR RIGHT	NO.	SQ. FT.
530	5	41 N.B.	STOP	36"	36"		2	18.00
			YIELD			48"	1	7.00
			DO NOT ENTER	30"	30"	30"	3	18.75
			ONE WAY	(2) 12"x 36"	(2) 12"x 36"		4	12.00
			WRONG WAY	30"x 42"	30"x 42"		2	17.50
			KEEP RIGHT					
530	5	41 S.B.	STOP	36"	36"		2	18.00
			YIELD			48"	1	7.00
			DO NOT ENTER	30"	30"	30"	3	18.75
			ONE WAY	(2) 12"x 36"	(2) 12"x 36"		4	12.00
			WRONG WAY	30"x 42"	30"x 42"		2	17.50
			KEEP RIGHT					
530	5	42 N.B.	STOP	36"	36"		2	18.00
			YIELD			48"	1	7.00
			DO NOT ENTER	30"	30"	30"	3	18.75
			ONE WAY	(2) 12"x 36"	(2) 12"x 36"		4	12.00
			WRONG WAY	30"x 42"	30"x 42"		2	17.50
			KEEP RIGHT					
530	5	42 S.B.	STOP	36"	36"		2	18.00
			YIELD			48"	1	7.00
			DO NOT ENTER	30"	30"	30"	3	18.75
			ONE WAY	(2) 12"x 36"	(2) 12"x 36"		4	12.00
			WRONG WAY	30"x 42"	30"x 42"		2	17.50
			KEEP RIGHT					
530	5	43 N.B.	STOP	36"	36"		2	18.00
			YIELD			48"	1	7.00
			DO NOT ENTER	36"	36"		2	18.00
			ONE WAY	(2) 18"x 54"	(2) 18"x 54"		4	27.00
			WRONG WAY	30"x 42"	30"x 42"		2	17.50
			KEEP RIGHT					
530	5	43 S.B.	STOP	36"	36"		2	18.00
			YIELD			48"	1	7.00
			DO NOT ENTER	36"	36"		2	18.00
			ONE WAY	(2) 18"x 54"	(2) 18"x 54"		4	27.00
			WRONG WAY	30"x 42"	30"x 42"		2	17.50
			KEEP RIGHT					
<b>SUBTOTAL:</b>							<b>391.50</b>	
<b>TOTAL JEFFERSON COUNTY:</b>							<b>1622.50</b>	
<b>TOTAL DISTRICT 2:</b>							<b>1622.50</b>	

STOP LINES, WRONG-WAY ARROWS, AND RAMP DELINEATORS

DISTRICT	COUNTY	ROUTE	MAIN LANE SECTION	RAMP SECTION	EXIT NUMBER	CROSS ROAD	STOP LINES	YIELD LINES	THERMO. WRONG-WAY PAVEMENT ARROWS	DELINEATOR (TYPE 2) YELLOW	DELINEATOR (TYPE 2) WHITE	TYPE OF RAMP
							LIN. FT.	LIN. FT.	EACH	EACH	EACH	
2	JEFFERSON	530	5	162	20	HWY. 46	24	20	1	20	20	TYPICAL DIAMOND
2	JEFFERSON	530	5	165	20	HWY. 46	24	18	1	17	21	TYPICAL DIAMOND
2	JEFFERSON	530	5	172	24	STAGECOACH RD.	20	20	1	15	18	TYPICAL DIAMOND
2	JEFFERSON	530	5	175	24	STAGECOACH RD.	24	22	1	15	18	TYPICAL DIAMOND
2	JEFFERSON	530	5	179	27	GRAVEL PIT RD.	24	18	1	16	19	TYPICAL DIAMOND
2	JEFFERSON	530	5	184	27	GRAVEL PIT RD.	18	18	1	17	19	TYPICAL DIAMOND
2	JEFFERSON	530	5	188	30	HWY. 104	24	16	1	18	21	TYPICAL DIAMOND
2	JEFFERSON	530	5	193	30	HWY. 104	20	20	1	18	21	TYPICAL DIAMOND
2	JEFFERSON	530	5	197	32	HWY. 256/HOLLAND AVE.	22	16	1	16	19	TYPICAL DIAMOND
2	JEFFERSON	530	5	202	32	HWY. 256/HOLLAND AVE.	17	17	1	15	18	TYPICAL DIAMOND
2	JEFFERSON	530	5	206	34	HWYS. 270/365	20	20	1	15	22	TYPICAL DIAMOND
2	JEFFERSON	530	5	211	34	HWYS. 270/365	14	20	1	15	18	TYPICAL DIAMOND
2	JEFFERSON	530	5	219	36	PRINCETON PIKE/BARRAQUE RD.	24	16	1	15	17	TYPICAL DIAMOND
2	JEFFERSON	530	5	226	37	HWY. 190/FRANKLIN	50		1	14	17	TYPICAL DIAMOND
2	JEFFERSON	530	5	231	37	HWY. 190/FRANKLIN	58		1	15	18	TYPICAL DIAMOND
2	JEFFERSON	530	5	235	39	HWY. 79B/54	24	20	1	15	17	TYPICAL DIAMOND
2	JEFFERSON	530	5	243	41	OLD WARREN RD.	26	16	1	13	16	TYPICAL DIAMOND
2	JEFFERSON	530	5	246	41	OLD WARREN RD.	24	15	1	13	15	TYPICAL DIAMOND
2	JEFFERSON	530	5	251	42	HAZEL ST.	45		1	16	19	TYPICAL DIAMOND
2	JEFFERSON	530	5	254	42	HAZEL ST.	30		1	15	18	TYPICAL DIAMOND
2	JEFFERSON	530	5	257	43	HWY. 63/63B	36		1	15	18	TYPICAL DIAMOND
2	JEFFERSON	530	5	259	43	HWY. 63/63B	30		1	14	16	TYPICAL DIAMOND
2	JEFFERSON	530	5	274	39	HWY. 79B/54	20	20	1	20	18	TYPICAL DIAMOND
2	JEFFERSON	530	5	276	36	PRINCETON PIKE/BARRAQUE RD.	25	20	1	14	17	TYPICAL DIAMOND
<b>TOTALS DISTRICT 2:</b>							<b>643</b>	<b>332</b>	<b>24</b>	<b>376</b>	<b>440</b>	

NOTE: REFER TO SHS MANUAL FOR DIMENSIONS FOR THERMOPLASTIC WRONG-WAY PAVEMENT ARROWS, THERMOPLASTIC WRONG-WAY PAVEMENT ARROWS SHALL BE PAID FOR UNDER "THERMOPLASTIC PAVEMENT MARKING (ARROWS)".

NOTE: RED VERTICAL STRIPS SHALL BE PLACED ON ALL WRONG-WAY & DO NOT ENTER SIGN POSTS.

DATE REVISED	DATE FILED	DATE REVISED	DATE FILED	FED. RD. DIST. NO.	STATE	FED. AID PROJ. NO.	SHEET NO.	TOTAL SHEETS
				6	ARK.			
						JOB NO. 012260	13	61

② QUANTITIES



DISTRICT 3  
MILLER COUNTY

DISTRICT 3  
MILLER COUNTY

DISTRICT 3  
MILLER COUNTY

ROUTE	SECT.	LOG MILE (EXIT NO.) DIRECTION	SIGNS	LOCATION AND SIZE			TOTAL SIGNS	
				LEFT	RIGHT	FAR RIGHT	NO.	SQ. FT.
49	21	4 N.B.	STOP	36"	36"		2	18.00
			YIELD			48"	1	7.00
			DO NOT ENTER	30"	30"	30"	3	18.75
			ONE WAY	(2) 12"x 36"	(2) 12"x 36"		4	12.00
			WRONG WAY	30"x 42"	30"x 42"		2	17.50
			KEEP RIGHT					
49	21	4 S.B.	STOP	36"	36"		2	18.00
			YIELD			48"	1	7.00
			DO NOT ENTER	30"	30"	30"	3	18.75
			ONE WAY	(2) 12"x 36"	(2) 12"x 36"		4	12.00
			WRONG WAY	30"x 42"	30"x 42"		2	17.50
			KEEP RIGHT					
49	21	6 N.B.	STOP	36"	36"		2	18.00
			YIELD					
			DO NOT ENTER	30"	30"		2	12.50
			ONE WAY	(2) 12"x 36"	(2) 12"x 36"		4	12.00
			WRONG WAY	30"x 42"	30"x 42"		2	17.50
			KEEP RIGHT					
49	21	6 S.B.	STOP	36"	36"		2	18.00
			YIELD					
			DO NOT ENTER	30"	30"		2	12.50
			ONE WAY	(2) 12"x 36"	(2) 12"x 36"		4	12.00
			WRONG WAY	30"x 42"	30"x 42"		2	17.50
			KEEP RIGHT					
49	21	16 N.B.	STOP	36"	36"		2	18.00
			YIELD			48"	1	7.00
			DO NOT ENTER	30"	30"	30"	3	18.75
			ONE WAY	(2) 12"x 36"	(2) 12"x 36"		4	12.00
			WRONG WAY	30"x 42"	30"x 42"		2	17.50
			KEEP RIGHT					
49	21	16 S.B.	STOP	36"	36"		2	18.00
			YIELD			48"	1	7.00
			DO NOT ENTER	30"	30"	30"	3	18.75
			ONE WAY	(2) 12"x 36"	(2) 12"x 36"		4	12.00
			WRONG WAY	30"x 42"	30"x 42"		2	17.50
			KEEP RIGHT					
SUBTOTAL:							413.00	

ROUTE	SECT.	LOG MILE (EXIT NO.) DIRECTION	SIGNS	LOCATION AND SIZE			TOTAL SIGNS	
				LEFT	RIGHT	FAR RIGHT	NO.	SQ. FT.
49	21	18 N.B.	STOP	36"	36"		2	18.00
			YIELD			48"	1	7.00
			DO NOT ENTER	30"	30"	30"	3	18.75
			ONE WAY	(2) 12"x 36"	(2) 12"x 36"		4	12.00
			WRONG WAY	30"x 42"	30"x 42"		2	17.50
			KEEP RIGHT					
49	21	18 S.B.	STOP	36"	36"		2	18.00
			YIELD			48"	1	7.00
			DO NOT ENTER	30"	30"	30"	3	18.75
			ONE WAY	(2) 12"x 36"	(2) 12"x 36"		4	12.00
			WRONG WAY	30"x 42"	30"x 42"		2	17.50
			KEEP RIGHT					
49	21	24 N.B.	STOP	36"	36"		2	18.00
			YIELD					
			DO NOT ENTER	30"	30"		2	12.50
			ONE WAY	(2) 12"x 36"	(2) 12"x 36"		4	12.00
			WRONG WAY	30"x 42"	30"x 42"		2	17.50
			KEEP RIGHT					
49	21	24 S.B.	STOP	36"	36"		2	18.00
			YIELD					
			DO NOT ENTER	30"	30"		2	12.50
			ONE WAY	(2) 12"x 36"	(2) 12"x 36"		4	12.00
			WRONG WAY	30"x 42"	30"x 42"		2	17.50
			KEEP RIGHT					
49	21	26 N.B.	STOP	36"	36"		2	18.00
			YIELD					
			DO NOT ENTER	30"	30"		2	12.50
			ONE WAY	(2) 12"x 36"	(2) 12"x 36"		4	12.00
			WRONG WAY	30"x 42"	30"x 42"		2	17.50
			KEEP RIGHT					
49	21	26 S.B.	STOP	36"	36"		2	18.00
			YIELD					
			DO NOT ENTER	30"	30"		2	12.50
			ONE WAY	(2) 12"x 36"	(2) 12"x 36"		4	12.00
			WRONG WAY	30"x 42"	30"x 42"		2	17.50
			KEEP RIGHT					
SUBTOTAL:							386.50	

ROUTE	SECT.	LOG MILE (EXIT NO.) DIRECTION	SIGNS	LOCATION AND SIZE			TOTAL SIGNS	
				LEFT	RIGHT	FAR RIGHT	NO.	SQ. FT.
49*	21*	29 A* N.B.	STOP	48"	48"		2	32.00
			YIELD			48"	1	7.00
			DO NOT ENTER	36"	36"	30"	2/1	24.25
			ONE WAY	(2) 18"x 54"	(2) 18"x 54"		4	27.00
			WRONG WAY	30"x 42"	30"x 42"		2	17.50
			KEEP RIGHT					
151	0	STATELINE AVE. W.B.	STOP	36"	36"		2	18.00
			YIELD			48"	1	7.00
			DO NOT ENTER	30"	30"	30"	3	18.75
			ONE WAY	(2) 12"x 36"	(2) 12"x 36"		4	12.00
			WRONG WAY	30"x 42"	30"x 42"		2	17.50
			KEEP RIGHT					
49	21	29 S.B.	STOP	48"	48"		2	32.00
			YIELD					
			DO NOT ENTER	36"	36"		2	18.00
			ONE WAY	(2) 18"x 54"	(2) 18"x 54"		4	27.00
			WRONG WAY	30"x 42"	30"x 42"		2	17.50
			KEEP RIGHT					
49	21	31 N.B.	STOP	48"	48"		2	32.00
			YIELD			48"	1	7.00
			DO NOT ENTER		36"	30"	1/1	15.25
			ONE WAY		(2) 18"x 54"		2	12.50
			WRONG WAY	30"x 42"	30"x 42"		2	17.50
			KEEP RIGHT	24"x 30"			1	
49	21	31 S.B.	STOP	48"	48"		2	18.00
			YIELD			48"	1	7.00
			DO NOT ENTER		36"	30"	1/1	15.25
			ONE WAY		(2) 18"x 54"		2	6.00
			WRONG WAY	30"x 42"	30"x 42"		2	17.50
			KEEP RIGHT	24"x 30"			1	5.00
49	21	32 U.S. 82 N.B.	STOP					
			YIELD					
			DO NOT ENTER	36"	36"		2	18.00
			ONE WAY	(2) 18"x 54"	(2) 18"x 54"		4	27.00
			WRONG WAY	30"x 42"	30"x 42"		2	17.50
			KEEP RIGHT					
SUBTOTAL:							491.00	

\*EXIT 29A ON I-49 TIES WITH EXIT 29 FROM HWY. 151, SECTION 0, TO MAKE ONE RAMP TERMINAL.

NOTE: RED VERTICAL STRIPS SHALL BE PLACED ON ALL WRONG-WAY & DO NOT ENTER SIGN POSTS.

r012260.dgn Quantities

9/26/16

DISTRICT 3  
QUANTITIES

DATE REVISED	DATE FILED	DATE REVISED	DATE FILED	FED. RD. DIST. NO.	STATE	FED. AID PROJ. NO.	SHEET NO.	TOTAL SHEETS
				6	ARK.			
JOB NO. 012260							14	61

2 QUANTITIES



DISTRICT 3  
MILLER COUNTY

DISTRICT 3  
MILLER COUNTY

DISTRICT 3  
MILLER COUNTY

ROUTE	SECT.	LOG MILE (EXIT NO.) DIRECTION	SIGNS	LOCATION AND SIZE			TOTAL SIGNS	
				LEFT	RIGHT	FAR RIGHT	NO.	SQ. FT.
49	21	32 U.S. 82 S.B.	STOP					
			YIELD					
			DO NOT ENTER	36"	36"		2	18.00
			ONE WAY	(2) 18"x 54"	(2) 18"x 54"		4	27.00
			WRONG WAY	30"x 42"	30"x 42"		2	17.50
49	21	32 19th ST. N.B.	STOP	36"	36"		2	18.00
			YIELD			48"	1	7.00
			DO NOT ENTER	30"	30"	30"	3	18.75
			ONE WAY	(2) 12"x 36"	(2) 12"x 36"		4	12.00
			WRONG WAY	30"x 42"	30"x 42"		2	17.50
49	21	32 19th ST. S.B.	STOP	36"	36"		2	18.00
			YIELD			48"	1	7.00
			DO NOT ENTER	30"	30"	30"	3	18.75
			ONE WAY	(2) 12"x 36"	(2) 12"x 36"		4	12.00
			WRONG WAY	30"x 42"	30"x 42"		2	17.50
49	21	35 ARKANSAS BLVD. N.B.	STOP	48"	48"		2	32.00
			YIELD					
			DO NOT ENTER		36"		1	9.00
			ONE WAY	(2) 18"x 54"	(2) 18"x 54"		4	27.00
			WRONG WAY	30"x 42"	30"x 42"		2	17.50
49	21	35 ARKANSAS BLVD. S.B.	STOP	36"	36"		2	18.00
			YIELD			48"	1	7.00
			DO NOT ENTER	30"	30"	30"	3	18.75
			ONE WAY	(2) 12"x 36"	(2) 12"x 36"		4	12.00
			WRONG WAY	30"x 42"	30"x 42"		2	17.50
49	21	41 N.B.	STOP	36"	36"		2	18.00
			YIELD			48"	2	14.00
			DO NOT ENTER	36"	36"	36"	3	27.00
			ONE WAY	(2) 12"x 36"	(2) 12"x 36"		4	12.00
			WRONG WAY	30"x 42"	30"x 42"		2	17.50
SUBTOTAL:							456.25	

ROUTE	SECT.	LOG MILE (EXIT NO.) DIRECTION	SIGNS	LOCATION AND SIZE			TOTAL SIGNS	
				LEFT	RIGHT	FAR RIGHT	NO.	SQ. FT.
49	21	41 S.B.	STOP	36"	36"		2	18.00
			YIELD			48"	1	7.00
			DO NOT ENTER	36"	36"		2	18.00
			ONE WAY	(2) 12"x 36"	(2) 12"x 36"		4	12.00
			WRONG WAY	30"x 42"	30"x 42"		2	17.50
49	21	42 N.B. HWY. 71	STOP	36"	36"		2	18.00
			YIELD			48"	1	7.00
			DO NOT ENTER	36"	36"	36"	3	18.00
			ONE WAY	(2) 12"x 36"	(2) 12"x 36"		4	12.00
			WRONG WAY	30"x 42"	30"x 42"		2	17.50
30	11	STATELINE AVE. W.B.	STOP			48"	1	7.00
			YIELD					
			DO NOT ENTER	36"	36"	30"	2/1	24.25
			ONE WAY	(2) 18"x 54"	(2) 18"x 54"		4	27.00
			WRONG WAY	30"x 42"	30"x 42"		2	17.50
30	11	1 E.B.	STOP	48"	48"		2	32.00
			YIELD			48"	1	7.00
			DO NOT ENTER	36"	36"	30"	2/1	24.25
			ONE WAY	(2) 18"x 54"	(2) 18"x 54"		4	27.00
			WRONG WAY	30"x 42"	30"x 42"		2	17.50
30	11	1 W.B.	STOP	48"	48"		2	32.00
			YIELD			48"	1	7.00
			DO NOT ENTER	36"	36"	30"	2/1	24.25
			ONE WAY	(2) 18"x 54"	(2) 18"x 54"		4	27.00
			WRONG WAY	30"x 42"	30"x 42"		2	17.50
30	11	2 E.B.	STOP	48"	48"		2	32.00
			YIELD			48"	1	7.00
			DO NOT ENTER	36"	36"	30"	2/1	24.25
			ONE WAY	(2) 18"x 54"	(2) 18"x 54"		4	27.00
			WRONG WAY	30"x 42"	30"x 42"		2	17.50
SUBTOTAL:							544.00	

ROUTE	SECT.	LOG MILE (EXIT NO.) DIRECTION	SIGNS	LOCATION AND SIZE			TOTAL SIGNS	
				LEFT	RIGHT	FAR RIGHT	NO.	SQ. FT.
30	11	2 W.B.	STOP			48"	1	7.00
			YIELD					
			DO NOT ENTER	36"	36"	30"	2/1	24.25
			ONE WAY	(2) 18"x 54"	(2) 18"x 54"		4	27.00
			WRONG WAY	30"x 42"	30"x 42"		2	17.50
30	11	7 E.B.	STOP	36"	36"		2	18.00
			YIELD					
			DO NOT ENTER	30"	30"		2	12.50
			ONE WAY	(2) 12"x 36"	(2) 12"x 36"		4	12.00
			WRONG WAY	30"x 42"	30"x 42"		2	17.50
30	11	7 W.B.	STOP	36"	36"		2	18.00
			YIELD					
			DO NOT ENTER	30"	30"		2	12.50
			ONE WAY	(2) 12"x 36"	(2) 12"x 36"		4	12.00
			WRONG WAY	30"x 42"	30"x 42"		2	17.50
30	11	12 E.B.	STOP	36"	36"		2	18.00
			YIELD					
			DO NOT ENTER	30"	30"		2	12.50
			ONE WAY	(2) 12"x 36"	(2) 12"x 36"		4	12.00
			WRONG WAY	30"x 42"	30"x 42"		2	17.50
SUBTOTAL:							255.75	
TOTAL MILLER COUNTY:							2546.50	

NOTE: RED VERTICAL STRIPS SHALL BE PLACED ON ALL WRONG-WAY & DO NOT ENTER SIGN POSTS.

DATE REVISED	DATE FILED	DATE REVISED	DATE FILED	FED. RD. DIST. NO.	STATE	FED. AID PROJ. NO.	SHEET NO.	TOTAL SHEETS
				6	ARK.			
						JOB NO. 012260	15	61

② QUANTITIES



DISTRICT 3  
HEMPSTEAD COUNTY

ROUTE	SECT.	LOG MILE (EXIT NO.) DIRECTION	SIGNS	LOCATION AND SIZE			TOTAL SIGNS	
				LEFT	RIGHT	FAR RIGHT	NO.	SQ. FT.
30	12	18 E.B.	STOP	36"	36"		2	18.00
			YIELD					
			DO NOT ENTER	30"	30"		2	12.50
			ONE WAY	(2) 12"x 36"	(2) 12"x 36"		4	12.00
			WRONG WAY	30"x 42"	30"x 42"		2	17.50
			KEEP RIGHT					
30	12	18 W.B.	STOP	36"	36"		2	18.00
			YIELD					
			DO NOT ENTER	30"	30"		2	12.50
			ONE WAY	(2) 12"x 36"	(2) 12"x 36"		4	12.00
			WRONG WAY	30"x 42"	30"x 42"		2	17.50
			KEEP RIGHT					
30	12	30 E.B.	STOP	48"	48"		2	32.00
			YIELD			48"	1	7.00
			DO NOT ENTER	36"	36"	30"	2/1	24.25
			ONE WAY	(2) 18"x 54"	(2) 18"x 54"		4	27.00
			WRONG WAY	30"x 42"	30"x 42"		2	17.50
			KEEP RIGHT					
30	12	30 W.B.	STOP					
			YIELD					
			DO NOT ENTER	36"	36"		2	18.00
			ONE WAY	(2) 18"x 54"	(2) 18"x 54"		4	27.00
			WRONG WAY	30"x 42"	30"x 42"		2	17.50
			KEEP RIGHT					
30	12	31 E.B.	STOP	48"	48"		2	32.00
			YIELD			48"	1	7.00
			DO NOT ENTER		36"	30"	1/1	15.25
			ONE WAY		(2) 18"x 54"		2	13.50
			WRONG WAY	30"x 42"	30"x 42"		2	17.50
			KEEP RIGHT	24"x 30"			1	5.00
30	12	31 W.B.	STOP	48"	48"		2	32.00
			YIELD			48"	1	7.00
			DO NOT ENTER		36"	30"	1/1	15.25
			ONE WAY		(2) 18"x 54"		2	13.50
			WRONG WAY	30"x 42"	30"x 42"		2	17.50
			KEEP RIGHT	24"x 30"			1	5.00
<b>SUBTOTAL:</b>								470.75

DISTRICT 3  
HEMPSTEAD COUNTY

ROUTE	SECT.	LOG MILE (EXIT NO.) DIRECTION	SIGNS	LOCATION AND SIZE			TOTAL SIGNS	
				LEFT	RIGHT	FAR RIGHT	NO.	SQ. FT.
30	12	36 E.B.	STOP	36"	36"		2	18.00
			YIELD			48"	1	7.00
			DO NOT ENTER	30"	30"	30"	3	18.75
			ONE WAY	(2) 12"x 36"	(2) 12"x 36"		4	12.00
			WRONG WAY	30"x 42"	30"x 42"		2	17.50
			KEEP RIGHT					
30	12	36 W.B.	STOP	36"	36"		2	18.00
			YIELD			48"	1	7.00
			DO NOT ENTER	30"	30"	30"	3	18.75
			ONE WAY	(2) 12"x 36"	(2) 12"x 36"		4	12.00
			WRONG WAY	30"x 42"	30"x 42"		2	17.50
			KEEP RIGHT					
<b>SUBTOTAL:</b>							146.50	
<b>TOTAL HEMPSTEAD COUNTY:</b>							617.25	

DISTRICT 3  
NEVADA COUNTY

ROUTE	SECT.	LOG MILE (EXIT NO.) DIRECTION	SIGNS	LOCATION AND SIZE			TOTAL SIGNS	
				LEFT	RIGHT	FAR RIGHT	NO.	SQ. FT.
30	13	44 E.B.	STOP	36"	36"		2	18.00
			YIELD					
			DO NOT ENTER	30"	30"		2	12.50
			ONE WAY	(2) 12"x 36"	(2) 12"x 36"		4	12.00
			WRONG WAY	30"x 42"	30"x 42"		2	17.50
			KEEP RIGHT					
30	13	44 W.B.	STOP	36"	36"		2	18.00
			YIELD			48"	1	7.00
			DO NOT ENTER	30"	30"	30"	3	18.75
			ONE WAY	(2) 12"x 36"	(2) 12"x 36"		4	12.00
			WRONG WAY	30"x 42"	30"x 42"		2	17.50
			KEEP RIGHT					
30	13	46 E.B.	STOP	36"	36"		2	18.00
			YIELD			48"	1	7.00
			DO NOT ENTER	30"	30"	30"	3	18.75
			ONE WAY	(2) 12"x 36"	(2) 12"x 36"		4	12.00
			WRONG WAY	30"x 42"	30"x 42"		2	17.50
			KEEP RIGHT					
30	13	46 W.B.	STOP	36"	36"		2	18.00
			YIELD			48"	1	7.00
			DO NOT ENTER	30"	30"	30"	3	18.75
			ONE WAY	(2) 12"x 36"	(2) 12"x 36"		4	12.00
			WRONG WAY	30"x 42"	30"x 42"		2	17.50
			KEEP RIGHT					
<b>TOTAL NEVADA COUNTY:</b>							279.75	
<b>TOTAL DISTRICT 3:</b>							3443.50	

NOTE: RED VERTICAL STRIPS SHALL BE PLACED ON ALL WRONG-WAY & DO NOT ENTER SIGN POSTS.

DATE REVISED	DATE FILMED	DATE REVISED	DATE FILMED	FED. RD. DIST. NO.	STATE	FED. AID PROJ. NO.	SHEET NO.	TOTAL SHEETS
12/13/16				6	ARK.			
				JOB NO.		012260	16	61

② QUANTITIES



STOP LINES, WRONG-WAY ARROWS, AND RAMP DELINEATORS

DISTRICT	COUNTY	ROUTE	MAIN LANE SECTION	RAMP SECTION	EXIT NUMBER	CROSS ROAD	STOP LINES	YIELD LINES	THERMO. WRONG-WAY PAVEMENT ARROWS	DELINEATOR (TYPE 2) YELLOW	DELINEATOR (TYPE 2) WHITE	TYPE OF RAMP
							LIN. FT.	LIN. FT.	EACH	EACH	EACH	
3	HEMPSTEAD	30	12	164	18	CR 1	27		1	23	17	MODIFIED DIAMOND
3	HEMPSTEAD	30	12	166	18	CR 1	45		1	20	22	MODIFIED DIAMOND
3	HEMPSTEAD	30	12	174	30	278	31	24	1	19	19	TYPICAL DIAMOND
3	HEMPSTEAD	30	12	178	30	278	33	26	1	19	19	TYPICAL DIAMOND
3	HEMPSTEAD	30	12	183	31	29	15	22	1	38	38	LOOP
3	HEMPSTEAD	30	12	189	36	299	32	18	1	22	18	MODIFIED DIAMOND
3	HEMPSTEAD	30	12	192	36	299	42	16	1	22	18	MODIFIED DIAMOND
3	HEMPSTEAD	30	12	576	WEIGH STATION	N/A			1	13	13	TYPICAL DIAMOND
3	HEMPSTEAD	30	12	579	WEIGH STATION	N/A			1	13	13	TYPICAL DIAMOND
3	HEMPSTEAD	30	12	597	31	29	16	25	1	21	19	MODIFIED DIAMOND
SUBTOTALS HEMPSTEAD COUNTY:							241	131	10	210	196	
3	MILLER	30	11	112	1	N/A			1	11	13	SLIP
3	MILLER	30	11	127	2	FOUR STATES FAIR PKWY.	15	16	3	7	16	TYPICAL DIAMOND
3	MILLER	30	11	137	7	108	20		1	20	27	MODIFIED DIAMOND
3	MILLER	30	11	141	7	108	40		1	20	27	MODIFIED DIAMOND
3	MILLER	30	11	157	12	67	75		1	20	16	TYPICAL DIAMOND
3	MILLER	30	11	548	2	FOUR STATES FAIR PKWY.	23	15	1	7	12	TYPICAL DIAMOND
3	MILLER	30	11	561	1	JEFFERSON AVE.	32	15	1	23	64	TYPICAL DIAMOND
3	MILLER	30	11	574	WELCOME CENTER	WELCOME CENTER			1	20	24	MODIFIED DIAMOND
3	MILLER	30	11	614	223	N/A	40	22	1	12	36	SLIP
3	MILLER	49	11	159	4	71	20	15	1	18	27	TYPICAL DIAMOND
3	MILLER	49	11	161	6	CR 197	33		1	23	23	MODIFIED DIAMOND
3	MILLER	49	11	163	6	CR 197	30		1	20	26	MODIFIED DIAMOND
3	MILLER	49	11	165	16	71	17	16	1	24	32	MODIFIED DIAMOND
3	MILLER	49	11	169	16	71	16	15	1	21	28	MODIFIED DIAMOND
3	MILLER	49	11	173	18	CR 88	15	15	1	20	29	MODIFIED DIAMOND
3	MILLER	49	11	177	18	CR 88	16	15	1	21	27	MODIFIED DIAMOND
3	MILLER	49	11	182	24	CR 10	67		1	11	16	MODIFIED DIAMOND
3	MILLER	49	11	186	24	CR 10	45		1	14	20	MODIFIED DIAMOND
3	MILLER	49	11	191	26	237	60		1	24	29	MODIFIED DIAMOND
3	MILLER	49	11	193	26	237	56		1	19	25	MODIFIED DIAMOND
3	MILLER	49	11	127	29 SB	71	61		1	12	15	TYPICAL DIAMOND
3	MILLER	49	11	128	31	196	15	15	1	25	28	MODIFIED DIAMOND
3	MILLER	49	11	133	31	196	15	15	1	9	55	LOOP
3	MILLER	49	11	137	32	82	15		1	14	20	TYPICAL DIAMOND
3	MILLER	49	11	214	32	82	37	18	2	31	57	TYPICAL DIAMOND
3	MILLER	49	11	144	32	19th STREET	21	24	1	12	17	TYPICAL DIAMOND
3	MILLER	49	11	148	32	19th STREET	20	26	1	8	7	TYPICAL DIAMOND
3	MILLER	49	11	197	29A	71	15	15	1	41	55	MODIFIED DIAMOND
3	MILLER	49	11	198	N/A	71	12	20	1	16	16	MODIFIED DIAMOND
3	MILLER	49	11	204	41	SANDERSON LANE	27	18	1	11	16	TYPICAL DIAMOND
3	MILLER	49	11	206	41	SANDERSON LANE	34	19	1	12	16	TYPICAL DIAMOND
3	MILLER	49	11	623	4	71	16	17	1	11	22	TYPICAL DIAMOND
3	MILLER	49	11	625	35	ARKANSAS BLVD.	43		1	20	31	MODIFIED DIAMOND
3	MILLER	49	11	627	35	ARKANSAS BLVD.	15	15	1	5	9	TYPICAL DIAMOND
3	MILLER	151		113	N/A	28	17	20	1	29	21	TYPICAL DIAMOND
3	MILLER	151		122	29	71			1	16	21	TYPICAL DIAMOND
SUBTOTALS MILLER COUNTY:							983	366	39	627	923	
3	NEVADA	30	13	196	44	371	39		1	25	25	MODIFIED DIAMOND
3	NEVADA	30	13	198	44	371	46	22	1	26	31	MODIFIED DIAMOND
3	NEVADA	30	13	202	46	19	33	23	1	22	20	MODIFIED DIAMOND
3	NEVADA	30	13	205	46	19	32	26	1	22	18	MODIFIED DIAMOND
SUBTOTALS NEVADA COUNTY:							150	71	4	95	94	
TOTALS DISTRICT 3:							1374	568	53	932	1213	

NOTE: REFER TO SHS MANUAL FOR DIMENSIONS FOR THERMOPLASTIC WRONG-WAY PAVEMENT ARROWS, THERMOPLASTIC WRONG-WAY PAVEMENT ARROWS SHALL BE PAID FOR UNDER "THERMOPLASTIC PAVEMENT MARKING (ARROWS)".

BARRIER WALL DELINEATORS

DISTRICT	COUNTY	ROUTE	SECTION	EXIT NO	CROSS ROAD	BARRIER LENGTH	NUMBER OF BARRIER WALL DELINEATORS
						LIN. FT.	EACH
3	MILLER	49	21	31	HWY. 196 SB	720	12
3	MILLER	49	21	31	HWY. 196 NB	735	8
3	MILLER	49	11	32	HWY. 82	2400	21
TOTAL DISTRICT 3:							41

LANE EXTENSIONS

DISTRICT	COUNTY	ROUTE	MAIN LANE SECTION	RAMP SECTION	EXIT NO	CROSS ROAD	LENGTH OF LANE EXTENSION
							LIN. FT.
3	HEMPSTEAD	29	12	188	31	29	20
3	HEMPSTEAD	30	12	183	31	29	20
TOTAL HEMPSTEAD COUNTY:							40
3	MILLER	49	21	131	31	196	10
3	MILLER	49	21	133	31	196	10
TOTAL MILLER COUNTY:							20
TOTAL DISTRICT 3:							60

NOTE: LANE EXTENSIONS SHALL BE DASHED, 4" WIDE, YELLOW PAVEMENT MARKINGS THAT GUIDE LEFT-TURNING TRAFFIC FROM THE CROSS ROAD TO THE CORRECT RAMP AT A FREEWAY INTERCHANGE. LANE EXTENSIONS SHALL BE PAID FOR UNDER "THERMOPLASTIC PAVEMENT MARKING YELLOW (6)".

DATE REVISED	DATE FILED	DATE REVISED	DATE FILED	FED. RD. DIST. NO.	STATE	FED. AID PROJ. NO.	SHEET NO.	TOTAL SHEETS
				6	ARK.			
						JOB NO. 012260	17	61

2 QUANTITIES



DISTRICT 4  
CRAWFORD COUNTY

ROUTE	SECT.	LOG MILE (EXIT NO.) DIRECTION	SIGNS	LOCATION AND SIZE			TOTAL SIGNS	
				LEFT	RIGHT	FAR RIGHT	NO.	SQ. FT.
40	11	1 W.B. (SLIP RAMP)	STOP					
			YIELD	* 48"	* 48"		2	32.00
			DO NOT ENTER	48"	48"		2	14.00
			ONE WAY					
			WRONG WAY	30"x 42"	30"x 42"		2	17.50
40	11	3 E.B.	KEEP RIGHT					
			STOP	36"	36"		2	18.00
			YIELD			48"	1	7.00
			DO NOT ENTER	30"	30"	30"	3	18.75
			ONE WAY	(2) 12"x 36"	(2) 12"x 36"		4	12.00
40	11	3 W.B.	WRONG WAY	30"x 42"	30"x 42"		2	17.50
			KEEP RIGHT					
			STOP	36"	36"		2	18.00
			YIELD			48"	1	7.00
			DO NOT ENTER	30"	30"	30"	3	18.75
40	11	5 E.B.	ONE WAY	(2) 12"x 36"	(2) 12"x 36"		4	12.00
			WRONG WAY	30"x 42"	30"x 42"		2	17.50
			KEEP RIGHT					
			STOP	36"	36"		2	18.00
			YIELD			48"	1	7.00
40	11	5 W.B.	DO NOT ENTER	36"	30"		1/1	15.25
			ONE WAY	(2) 18"x 54"	(2) 18"x 54"		4	27.00
			WRONG WAY	30"x 42"	30"x 42"		2	17.50
			KEEP RIGHT					
			STOP	36"	36"		2	18.00
40	11	13 E.B.	YIELD					
			DO NOT ENTER	36"	36"		2	18.00
			ONE WAY	(2) 18"x 54"	(2) 18"x 54"		4	27.00
			WRONG WAY	30"x 42"	30"x 42"		2	17.50
			KEEP RIGHT					
<b>SUBTOTAL:</b>							<b>401.75</b>	

\* ON INTERSECTING ROADWAY  
ON ALL SLIP RAMPS TO TWO-WAY FRONTAGE ROADS, (2) 48" W6-3  
SIGNS ARE REQUIRED ON THE FRONTAGE ROAD JUST BEYOND THE RAMP.

DISTRICT 4  
CRAWFORD COUNTY

ROUTE	SECT.	LOG MILE (EXIT NO.) DIRECTION	SIGNS	LOCATION AND SIZE			TOTAL SIGNS	
				LEFT	RIGHT	FAR RIGHT	NO.	SQ. FT.
40	11	13 W.B.	STOP					
			YIELD					
			DO NOT ENTER	36"	36"		2	18.00
			ONE WAY	(2) 18"x 54"	(2) 18"x 54"		4	27.00
			WRONG WAY	30"x 42"	30"x 42"		2	17.50
40	11	20 E.B.	KEEP RIGHT					
			STOP	36"	36"		2	18.00
			YIELD					
			DO NOT ENTER	30"	30"		2	12.50
			ONE WAY	(2) 12"x 36"	(2) 12"x 36"		4	12.00
40	11	20 W.B.	WRONG WAY	30"x 42"	30"x 42"		2	17.50
			KEEP RIGHT					
			STOP	36"	36"		2	18.00
			YIELD					
			DO NOT ENTER	30"	30"		2	12.50
40	11	24 E.B.	ONE WAY	(2) 12"x 36"	(2) 12"x 36"		4	12.00
			WRONG WAY	30"x 42"	30"x 42"		2	17.50
			KEEP RIGHT					
			STOP	36"	36"		2	18.00
			YIELD			48"	1	7.00
40	11	24 W.B.	DO NOT ENTER	30"	30"	30"	3	18.75
			ONE WAY	(2) 12"x 36"	(2) 12"x 36"		4	12.00
			WRONG WAY	30"x 42"	30"x 42"		2	17.50
			KEEP RIGHT					
			STOP	36"	36"		2	18.00
540	2	3 N.B.	YIELD			48"	1	7.00
			DO NOT ENTER	36"	36"	(2) 48"	2/2	50.00
			ONE WAY	(2) 12"x 36"	(2) 12"x 36"		4	12.00
			WRONG WAY	30"x 42"	30"x 42"		2	17.50
			KEEP RIGHT					
<b>SUBTOTAL:</b>							<b>433.50</b>	

DISTRICT 4  
CRAWFORD COUNTY

ROUTE	SECT.	LOG MILE (EXIT NO.) DIRECTION	SIGNS	LOCATION AND SIZE			TOTAL SIGNS	
				LEFT	RIGHT	FAR RIGHT	NO.	SQ. FT.
540	2	3 S.B.	STOP	36"	36"		2	18.00
			YIELD			48"	1	7.00
			DO NOT ENTER	36"	36"		2	18.00
			ONE WAY	(2) 12"x 36"	(2) 12"x 36"		4	12.00
			WRONG WAY	30"x 42"	30"x 42"		2	17.50
49	27	21 N.B.	KEEP RIGHT					
			STOP	48"	48"		2	32.00
			YIELD					
			DO NOT ENTER		36"		1	9.00
			ONE WAY		(2) 18"x 54"		2	13.50
49	27	21 S.B.	WRONG WAY	30"x 42"	30"x 42"		2	17.50
			KEEP RIGHT	24"x 30"			1	5.00
			STOP	48"	48"		2	32.00
			YIELD					
			DO NOT ENTER		36"		1	9.00
49	27	24 N.B.	ONE WAY		(2) 18"x 54"		2	13.50
			WRONG WAY	30"x 42"	30"x 42"		2	17.50
			KEEP RIGHT	24"x 30"			1	5.00
			STOP	36"	36"		2	18.00
			YIELD			48"	1	7.00
49	27	24 S.B.	DO NOT ENTER	30"	30"	30"	3	18.75
			ONE WAY	(2) 12"x 36"	(2) 12"x 36"		4	12.00
			WRONG WAY	30"x 42"	30"x 42"		2	17.50
			KEEP RIGHT					
			STOP	36"	36"		2	18.00
49	27	29 N.B.	YIELD			48"	1	7.00
			DO NOT ENTER	30"	30"	30"	3	18.75
			ONE WAY	(2) 12"x 36"	(2) 12"x 36"		4	12.00
			WRONG WAY	30"x 42"	30"x 42"		2	17.50
			KEEP RIGHT					
<b>SUBTOTAL:</b>							<b>446.25</b>	

NOTE: RED VERTICAL STRIPS SHALL BE PLACED ON ALL WRONG-WAY & DO NOT ENTER SIGN POSTS.

DATE REVISED	DATE FILMED	DATE REVISED	DATE FILMED	FED. RD. DIST. NO.	STATE	FED. AID PROJ. NO.	SHEET NO.	TOTAL SHEETS
				6	ARK.			
JOB NO. 012260							18	61

② QUANTITIES



DISTRICT 4  
CRAWFORD COUNTY

ROUTE	SECT.	LOG MILE (EXIT NO.) DIRECTION	SIGNS	LOCATION AND SIZE			TOTAL SIGNS	
				LEFT	RIGHT	FAR RIGHT	NO.	SQ. FT.
49	27	29 S.B.	STOP	36"	36"		2	18.00
			YIELD			48"	1	7.00
			DO NOT ENTER	30"	30"	30"	3	18.75
			ONE WAY	(2) 12"x 36"	(2) 12"x 36"		4	12.00
			WRONG WAY	30"x 42"	30"x 42"		2	17.50
			KEEP RIGHT					
49	27	34 N.B.	STOP	48"	48"		2	32.00
			YIELD					
			DO NOT ENTER		36"		1	9.00
			ONE WAY		(2) 18"x 54"		2	13.50
			WRONG WAY	30"x 42"	30"x 42"		2	17.50
			KEEP RIGHT	24"x 30"			1	5.00
49	27	34 S.B.	STOP	48"	48"		2	32.00
			YIELD					
			DO NOT ENTER		36"		1	9.00
			ONE WAY		(2) 18"x 54"		2	13.50
			WRONG WAY	30"x 42"	30"x 42"		2	17.50
			KEEP RIGHT	24"x 30"			1	5.00
SUBTOTAL:							227.25	
TOTAL CRAWFORD COUNTY:							1508.75	

DISTRICT 4  
FRANKLIN COUNTY

ROUTE	SECT.	LOG MILE (EXIT NO.) DIRECTION	SIGNS	LOCATION AND SIZE			TOTAL SIGNS	
				LEFT	RIGHT	FAR RIGHT	NO.	SQ. FT.
40	12	35 E.B.	STOP	36"	36"		2	18.00
			YIELD			48"	1	7.00
			DO NOT ENTER	30"	30"	30"	3	18.75
			ONE WAY	(2) 12"x 36"	(2) 12"x 36"		4	12.00
			WRONG WAY	30"x 42"	30"x 42"		2	17.50
			KEEP RIGHT					
40	12	35 W.B.	STOP	36"	36"		2	18.00
			YIELD			48"	1	7.00
			DO NOT ENTER	30"	30"	30"	3	18.75
			ONE WAY	(2) 12"x 36"	(2) 12"x 36"		4	12.00
			WRONG WAY	30"x 42"	30"x 42"		2	17.50
			KEEP RIGHT					
40	12	37 E.B.	STOP	36"	36"		2	18.00
			YIELD			48"	1	7.00
			DO NOT ENTER	30"	30"	30"	3	18.75
			ONE WAY	(2) 12"x 36"	(2) 12"x 36"		4	12.00
			WRONG WAY	30"x 42"	30"x 42"		2	17.50
			KEEP RIGHT					
40	12	37 W.B.	STOP	36"	36"		2	18.00
			YIELD			48"	1	7.00
			DO NOT ENTER	30"	30"	30"	3	18.75
			ONE WAY	(2) 12"x 36"	(2) 12"x 36"		4	12.00
			WRONG WAY	30"x 42"	30"x 42"		2	17.50
			KEEP RIGHT					
40	12	41 E.B.	STOP	36"	36"		2	18.00
			YIELD			48"	1	7.00
			DO NOT ENTER	30"	30"	30"	3	18.75
			ONE WAY	(2) 12"x 36"	(2) 12"x 36"		4	12.00
			WRONG WAY	30"x 42"	30"x 42"		2	17.50
			KEEP RIGHT					
40	12	41 W.B.	STOP	36"	36"		2	18.00
			YIELD			48"	1	7.00
			DO NOT ENTER	30"	30"	30"	3	18.75
			ONE WAY	(2) 12"x 36"	(2) 12"x 36"		4	12.00
			WRONG WAY	30"x 42"	30"x 42"		2	17.50
			KEEP RIGHT					
TOTAL FRANKLIN COUNTY:							439.50	

DISTRICT 4  
SEBASTIAN COUNTY

ROUTE	SECT.	LOG MILE (EXIT NO.) DIRECTION	SIGNS	LOCATION AND SIZE			TOTAL SIGNS	
				LEFT	RIGHT	FAR RIGHT	NO.	SQ. FT.
540	1	14 N.B.	STOP			48"	1	7.00
			YIELD					
			DO NOT ENTER	36"	36"	30"	2/1	24.25
			ONE WAY	(2) 18"x 54"	(2) 18"x 54"		4	27.00
			WRONG WAY	30"x 42"	30"x 42"		2	17.50
			KEEP RIGHT					
540	1	14 S.B.	STOP			48"	1	7.00
			YIELD					
			DO NOT ENTER	36"	36"	30"	2/1	24.25
			ONE WAY	(2) 18"x 54"	(2) 18"x 54"		4	27.00
			WRONG WAY	30"x 42"	30"x 42"		2	17.50
			KEEP RIGHT					
540	1	13 N.B.	STOP					
			YIELD					
			DO NOT ENTER	36"	36"		2	18.00
			ONE WAY	(2) 18"x 54"	(2) 18"x 54"		4	27.00
			WRONG WAY	30"x 42"	30"x 42"		2	17.50
			KEEP RIGHT					
540	1	13 S.B.	STOP			48"	1	7.00
			YIELD					
			DO NOT ENTER	36"	36"	30"	2/1	24.25
			ONE WAY	(2) 18"x 54"	(2) 18"x 54"		4	27.00
			WRONG WAY	30"x 42"	30"x 42"		2	17.50
			KEEP RIGHT					
540	1	12 N.B.	STOP	48"	48"		2	32.00
			YIELD			48"	1	7.00
			DO NOT ENTER	36"	36"	30"	2/1	24.25
			ONE WAY	(2) 18"x 54"	(2) 18"x 54"		4	27.00
			WRONG WAY	30"x 42"	30"x 42"		2	17.50
			KEEP RIGHT					
540	1	12 S.B.	STOP			48"	1	7.00
			YIELD					
			DO NOT ENTER	36"	36"	30"	2/1	24.25
			ONE WAY	(2) 18"x 54"	(2) 18"x 54"		4	27.00
			WRONG WAY	30"x 42"	30"x 42"		2	17.50
			KEEP RIGHT					
SUBTOTAL:							473.25	

NOTE: RED VERTICAL STRIPS SHALL BE PLACED ON ALL WRONG-WAY & DO NOT ENTER SIGN POSTS.

DATE REVISED	DATE FILMED	DATE REVISED	DATE FILMED	FED. RD. DIST. NO.	STATE	FED. AID PROJ. NO.	SHEET NO.	TOTAL SHEETS
				6	ARK.			
				JOB NO.	012260		19	61

② QUANTITIES



DISTRICT 4  
SEBASTIAN COUNTY

ROUTE	SECT.	LOG MILE (EXIT NO.) DIRECTION	SIGNS	LOCATION AND SIZE			TOTAL SIGNS	
				LEFT	RIGHT	FAR RIGHT	NO.	SQ. FT.
540	1	11 N.B.	STOP					
			YIELD					
			DO NOT ENTER	36"	36"		2	18.00
			ONE WAY	(2) 18"x 54"	(2) 18"x 54"		4	27.00
			WRONG WAY	30"x 42"	30"x 42"		2	17.50
KEEP RIGHT								
540	1	11 S.B.	STOP					
			YIELD					
			DO NOT ENTER	36"	36"		2	18.00
			ONE WAY	(2) 18"x 54"	(2) 18"x 54"		4	27.00
			WRONG WAY	30"x 42"	30"x 42"		2	17.50
KEEP RIGHT								
540	1	10 N.B.	STOP			48"	1	7.00
			YIELD					
			DO NOT ENTER	36"	36"	30"	2/1	24.25
			ONE WAY	(2) 18"x 54"	(2) 18"x 54"		4	27.00
			WRONG WAY	30"x 42"	30"x 42"		2	17.50
KEEP RIGHT								
540	1	10 S.B.	STOP	48"	48"		2	32.00
			YIELD			48"	1	7.00
			DO NOT ENTER	36"	36"	30"	2/1	24.25
			ONE WAY	(2) 18"x 54"	(2) 18"x 54"		4	27.00
			WRONG WAY	30"x 42"	30"x 42"		2	17.50
KEEP RIGHT								
540	1	9 N.B.	STOP	48"	48"		2	32.00
			YIELD					
			DO NOT ENTER	36"	36"	36"	2/1	24.25
			ONE WAY	(2) 18"x 54"	(2) 18"x 54"		4	27.00
			WRONG WAY	30"x 42"	30"x 42"		1	8.75
KEEP RIGHT								
540	1	9 S.B.	STOP	36"	36"		2	32.00
			YIELD			48"	1	7.00
			DO NOT ENTER	30"	30"	30"	3	18.75
			ONE WAY	(2) 12"x 36"	(2) 12"x 36"		4	12.00
			WRONG WAY	30"x 42"	30"x 42"		2	17.50
KEEP RIGHT								
SUBTOTAL:							487.75	

DISTRICT 4  
SEBASTIAN COUNTY

ROUTE	SECT.	LOG MILE (EXIT NO.) DIRECTION	SIGNS	LOCATION AND SIZE			TOTAL SIGNS	
				LEFT	RIGHT	FAR RIGHT	NO.	SQ. FT.
540	1	8 N.B.	STOP					
			YIELD					
			DO NOT ENTER	48"	48"	(2) 48"	4	64.00
			ONE WAY	(2) 18"x 54"	(2) 18"x 54"		4	27.00
			WRONG WAY	30"x 42"	30"x 42"		2	
KEEP RIGHT								
540	1	8A S.B.	STOP					
			YIELD	48"	48"		2	14.00
			DO NOT ENTER	36"	36"		2	18.00
			ONE WAY	(2) 18"x 54"	(2) 18"x 54"		4	27.00
			WRONG WAY	30"x 42"	30"x 42"		2	17.50
KEEP RIGHT								
540	1	8B S.B.	STOP					
			YIELD	48"	48"		2	14.00
			DO NOT ENTER	36"	36"		2	18.00
			ONE WAY	(2) 18"x 54"	(2) 18"x 54"		4	27.00
			WRONG WAY	30"x 42"	30"x 42"		2	17.50
KEEP RIGHT								
540	1	6 N.B.	STOP					
			YIELD					
			DO NOT ENTER	36"	36"		2	18.00
			ONE WAY	(2) 18"x 54"	(2) 18"x 54"		4	27.00
			WRONG WAY	30"x 42"	30"x 42"		2	17.50
KEEP RIGHT								
540	1	6 S.B.	STOP					
			YIELD					
			DO NOT ENTER	36"	36"		2	18.00
			ONE WAY	(2) 18"x 54"	(2) 18"x 54"		4	27.00
			WRONG WAY	30"x 42"	30"x 42"		2	17.50
KEEP RIGHT								
540	1	5 N.B.	STOP					
			YIELD			48"	1	7.00
			DO NOT ENTER	36"	36"	30"	2/1	24.25
			ONE WAY	(2) 18"x 54"	(2) 18"x 54"		4	27.00
			WRONG WAY	30"x 42"	30"x 42"		2	17.50
KEEP RIGHT								
SUBTOTAL:							444.75	

DISTRICT 4  
SEBASTIAN COUNTY

ROUTE	SECT.	LOG MILE (EXIT NO.) DIRECTION	SIGNS	LOCATION AND SIZE			TOTAL SIGNS	
				LEFT	RIGHT	FAR RIGHT	NO.	SQ. FT.
540	1	5 S.B.	STOP					
			YIELD			48"	1	7.00
			DO NOT ENTER	36"	36"	30"	2/1	24.25
			ONE WAY	(2) 18"x 54"	(2) 18"x 54"		4	27.00
			WRONG WAY	30"x 42"	30"x 42"		2	17.50
KEEP RIGHT								
549	6	187 S.B.	STOP					
			YIELD					
			DO NOT ENTER	36"	36"		2	18.00
			ONE WAY	(4) 18"x 54"	(4) 18"x 54"		8	54.00
			WRONG WAY	30"x 42"	30"x 42"		2	17.50
KEEP RIGHT								
549	6	190 N.B.	STOP	36"	36"		2	18.00
			YIELD			48"	1	7.00
			DO NOT ENTER	30"	30"		2	12.50
			ONE WAY	(2) 12"x 36"	(2) 12"x 36"		4	12.00
			WRONG WAY	30"x 42"	30"x 42"		2	17.50
KEEP RIGHT								
549	6	190 S.B.	STOP	36"	36"		2	18.00
			YIELD			48"	1	7.00
			DO NOT ENTER	30"	30"		2	12.50
			ONE WAY	(2) 12"x 36"	(2) 12"x 36"		4	12.00
			WRONG WAY	30"x 42"	30"x 42"		2	17.50
KEEP RIGHT								
549	6	191 N.B.	STOP	36"	36"		2	18.00
			YIELD			48"	1	7.00
			DO NOT ENTER	30"	30"		2	12.50
			ONE WAY	(2) 12"x 36"	(2) 12"x 36"		4	12.00
			WRONG WAY	30"x 42"	30"x 42"		2	17.50
KEEP RIGHT								
549	6	191 S.B.	STOP	36"	36"		2	18.00
			YIELD			48"	1	7.00
			DO NOT ENTER	30"	30"		2	12.50
			ONE WAY	(2) 12"x 36"	(2) 12"x 36"		4	12.00
			WRONG WAY	30"x 42"	30"x 42"		2	17.50
KEEP RIGHT								
549	6	193 N.B.	STOP	48"	48"		2	32.00
			YIELD					
			DO NOT ENTER	36"	36"		2	18.00
			ONE WAY	(2) 18"x 54"	(2) 18"x 54"		4	27.00
			WRONG WAY	30"x 42"	30"x 42"		2	17.50
KEEP RIGHT								
SUBTOTAL:							527.75	
TOTAL SEBASTIAN COUNTY:							1933.50	

NOTE: RED VERTICAL STRIPS SHALL BE PLACED ON ALL WRONG-WAY & DO NOT ENTER SIGN POSTS.

DATE REVISED	DATE FILMED	DATE REVISED	DATE FILMED	FED. RD. DIST. NO.	STATE	FED. AID PROJ. NO.	SHEET NO.	TOTAL SHEETS
12/13/16				6	ARK.		20	61
				JOB NO.		012260	20	61

② QUANTITIES



DISTRICT 4  
WASHINGTON COUNTY

ROUTE	SECT.	LOG MILE (EXIT NO.) DIRECTION	SIGNS	LOCATION AND SIZE			TOTAL SIGNS	
				LEFT	RIGHT	FAR RIGHT	NO.	SQ. FT.
49	28	45 N.B.	STOP	36"	36"		2	18.00
			YIELD			48"	1	7.00
			DO NOT ENTER	30"	30"	30"	3	18.75
			ONE WAY	(2) 12"x 36"	(2) 12"x 36"		4	12.00
			WRONG WAY	30"x 42"	30"x 42"		2	17.50
KEEP RIGHT								
49	28	45 S.B.	STOP	36"	36"		2	18.00
			YIELD			48"	1	7.00
			DO NOT ENTER	30"	30"	30"	3	18.75
			ONE WAY	(2) 12"x 36"	(2) 12"x 36"		4	12.00
			WRONG WAY	30"x 42"	30"x 42"		2	17.50
KEEP RIGHT								
49	28	53 N.B.	STOP	36"	36"		2	18.00
			YIELD			48"	1	7.00
			DO NOT ENTER	30"	30"	30"	3	18.75
			ONE WAY	(2) 12"x 36"	(2) 12"x 36"		4	12.00
			WRONG WAY	30"x 42"	30"x 42"		2	17.50
KEEP RIGHT								
49	28	53 S.B.	STOP	36"	36"		2	18.00
			YIELD			48"	1	7.00
			DO NOT ENTER	30"	30"	30"	3	18.75
			ONE WAY	(2) 12"x 36"	(2) 12"x 36"		4	12.00
			WRONG WAY	30"x 42"	30"x 42"		2	17.50
KEEP RIGHT								
49	28	58 N.B.	STOP	36"	36"		2	18.00
			YIELD			48"	1	7.00
			DO NOT ENTER	30"	30"	30"	3	18.75
			ONE WAY	(2) 12"x 36"	(2) 12"x 36"		4	12.00
			WRONG WAY	30"x 42"	30"x 42"		2	17.50
KEEP RIGHT								
49	28	58 S.B.	STOP	36"	36"		2	18.00
			YIELD			48"	1	7.00
			DO NOT ENTER	30"	30"	30"	3	18.75
			ONE WAY	(2) 12"x 36"	(2) 12"x 36"		4	12.00
			WRONG WAY	30"x 42"	30"x 42"		2	17.50
KEEP RIGHT								
<b>SUBTOTAL:</b>							439.50	

DISTRICT 4  
WASHINGTON COUNTY

ROUTE	SECT.	LOG MILE (EXIT NO.) DIRECTION	SIGNS	LOCATION AND SIZE			TOTAL SIGNS	
				LEFT	RIGHT	FAR RIGHT	NO.	SQ. FT.
49	28	60 N.B.	STOP	36"	36"		2	18.00
			YIELD			48"	1	7.00
			DO NOT ENTER	30"	30"	30"	3	18.75
			ONE WAY	(2) 12"x 36"	(2) 12"x 36"		4	12.00
			WRONG WAY	30"x 42"	30"x 42"		2	17.50
KEEP RIGHT								
49	28	60 S.B.	STOP	36"	36"		2	18.00
			YIELD			48"	1	7.00
			DO NOT ENTER	30"	30"	30"	3	18.75
			ONE WAY	(2) 12"x 36"	(2) 12"x 36"		4	12.00
			WRONG WAY	30"x 42"	30"x 42"		2	17.50
KEEP RIGHT								
49	28	62 N.B.	STOP	48"	48"		2	32.00
			YIELD					
			DO NOT ENTER	36"	36"		2	18.00
			ONE WAY	(2) 18"x 54"	(2) 18"x 54"		4	27.00
			WRONG WAY	30"x 42"	30"x 42"		2	17.50
KEEP RIGHT								
49	28	64 N.B.	STOP					
			YIELD			48"	1	7.00
			DO NOT ENTER	36"	36"	30"	2/1	24.25
			ONE WAY	(2) 18"x 54"	(2) 18"x 54"		4	27.00
			WRONG WAY	30"x 42"	30"x 42"		2	17.50
KEEP RIGHT								
49	28	64 S.B.	STOP					
			YIELD					
			DO NOT ENTER	36"	36"		2	18.00
			ONE WAY	(2) 18"x 54"	(2) 18"x 54"		4	27.00
			WRONG WAY	30"x 42"	30"x 42"		2	17.50
KEEP RIGHT								
49	28	65 N.B.	STOP					
			YIELD					
			DO NOT ENTER	36"	36"		2	18.00
			ONE WAY	(2) 18"x 54"	(2) 18"x 54"		4	27.00
			WRONG WAY	30"x 42"	30"x 42"		2	17.50
KEEP RIGHT								
<b>SUBTOTAL:</b>							441.75	

EXIT 62 S.B. IS A SLIP RAMP ONTO A ONE-WAY FRONTAGE ROAD AND IS NOT SUBJECT TO THE REQUIREMENTS OF SECTION 2B.41.

DISTRICT 4  
WASHINGTON COUNTY

ROUTE	SECT.	LOG MILE (EXIT NO.) DIRECTION	SIGNS	LOCATION AND SIZE			TOTAL SIGNS	
				LEFT	RIGHT	FAR RIGHT	NO.	SQ. FT.
49	28	65 S.B.	STOP					
			YIELD					
			DO NOT ENTER	36"	36"		2	18.00
			ONE WAY	(2) 18"x 54"	(2) 18"x 54"		4	27.00
			WRONG WAY	30"x 42"	30"x 42"		2	17.50
KEEP RIGHT								
49	28	69 N.B.	STOP	48"	48"		2	32.00
			YIELD			48"	1	7.00
			DO NOT ENTER	36"	36"	30"	2/1	24.25
			ONE WAY	(2) 18"x 54"	(2) 18"x 54"		4	27.00
			WRONG WAY	30"x 42"	30"x 42"		2	17.50
KEEP RIGHT								
49	28	69 S.B.	STOP	48"	48"		2	32.00
			YIELD			48"	1	7.00
			DO NOT ENTER	36"	36"	30"	2/1	24.25
			ONE WAY	(2) 18"x 54"	(2) 18"x 54"		4	27.00
			WRONG WAY	30"x 42"	30"x 42"		2	17.50
KEEP RIGHT								
49	28	70 N.B.	STOP					
			YIELD					
			DO NOT ENTER		36"		1	9.00
			ONE WAY		(2) 18"x 54"		2	13.50
			WRONG WAY	30"x 42"	30"x 42"		2	17.50
KEEP RIGHT		24"x 30"		1	5.00			
<b>SUBTOTAL:</b>							323.00	

NOTE: RED VERTICAL STRIPS SHALL BE PLACED ON ALL WRONG-WAY & DO NOT ENTER SIGN POSTS.

DISTRICT 4  
WASHINGTON COUNTY

DATE REVISED	DATE FILMED	DATE REVISED	DATE FILMED	FED. RD. DIST. NO.	STATE	FED. AID PROJ. NO.	SHEET NO.	TOTAL SHEETS	
12/13/16				6	ARK.				
							JOB NO. 012260	21	61

② QUANTITIES



ROUTE	SECT.	LOG MILE (EXIT NO.) DIRECTION	SIGNS	LOCATION AND SIZE			TOTAL SIGNS	
				LEFT	RIGHT	FAR RIGHT	NO.	SQ. FT.
49	28	70 S.B.	STOP	48"	48"		2	32.00
			YIELD			48"	1	7.00
			DO NOT ENTER		36"	36"	2	18.00
			ONE WAY		(2) 18"x 54"	(2) 12"x 36"	4	27.00
			WRONG WAY	30"x 42"	30"x 42"		2	17.50
			KEEP RIGHT	24"x 30"			1	5.00
49	28	72 N.B.	STOP					
			YIELD			48"	1	7.00
			DO NOT ENTER	36"	36"	30"	2/1	24.25
			ONE WAY	(2) 18"x 54"	(2) 18"x 54"		4	27.00
			WRONG WAY	30"x 42"	30"x 42"		2	17.50
			KEEP RIGHT					
49	28	72 S.B.	STOP					
			YIELD			48"	1	7.00
			DO NOT ENTER	36"	36"	30"	2/1	24.25
			ONE WAY	(2) 18"x 54"	(2) 18"x 54"		4	27.00
			WRONG WAY	30"x 42"	30"x 42"		2	17.50
			KEEP RIGHT					
SUBTOTAL:								312.00

DISTRICT 4  
WASHINGTON COUNTY

ROUTE	SECT.	LOG MILE (EXIT NO.) DIRECTION	SIGNS	LOCATION AND SIZE			TOTAL SIGNS	
				LEFT	RIGHT	FAR RIGHT	NO.	SQ. FT.
71	17B	GREGG ST. S.B.	STOP	48"	48"		2	32.00
			YIELD					
			DO NOT ENTER		36"		1	9.00
			ONE WAY		(2) 18"x 54"		2	13.50
			WRONG WAY	30"x 42"	30"x 42"		2	17.50
			KEEP RIGHT	24"x 30"			1	5.00
71	16	60 N.B.	STOP	48"	48"		2	32.00
			YIELD			48"	1	7.00
			DO NOT ENTER		36"	30"	1/1	15.25
			ONE WAY		(2) 18"x 54"		2	13.50
			WRONG WAY	30"x 42"	30"x 42"		2	17.50
			KEEP RIGHT	24"x 30"			1	5.00
71	17B	GREGG ST. N.B.	STOP					
			YIELD					
			DO NOT ENTER					
			ONE WAY					
			WRONG WAY	30"x 42"	30"x 42"		2	17.50
			KEEP RIGHT					
SUBTOTAL:								184.75
TOTAL WASHINGTON COUNTY:								1998.25
TOTAL DISTRICT 4:								5880.00

NOTE: RED VERTICAL STRIPS SHALL BE PLACED ON ALL WRONG-WAY & DO NOT ENTER SIGN POSTS.

STOP LINES, WRONG-WAY ARROWS, AND RAMP DELINEATORS (BOX 1 OF 2)

DISTRICT	COUNTY	ROUTE	MAIN LANE SECTION	RAMP SECTION	EXIT NUMBER	CROSS ROAD	STOP LINES	YIELD LINES	THERMO. WRONG-WAY PAVEMENT ARROWS	DELINEATOR (TYPE 2) YELLOW	DELINEATOR (TYPE 2) WHITE	TYPE OF RAMP
							LIN. FT.	LIN. FT.	EACH	EACH	EACH	
4	CRAWFORD	40	11	113	1	900/DORA ROAD			1	20	31	SLIP
4	CRAWFORD	40	11	117	3	LEE CREEK RD.	26	8	1	38	61	MODIFIED DIAMOND
4	CRAWFORD	40	11	122	3	LEE CREEK RD.	22	9	1	34	58	MODIFIED DIAMOND
4	CRAWFORD	40	11	127	5	59	53		1	24	43	TYPICAL DIAMOND
4	CRAWFORD	40	11	132	5	59	21	9	1	23	40	TYPICAL DIAMOND
4	CRAWFORD	40	11	138	N/A	WEIGH STATION			1	22	29	TYPICAL DIAMOND
4	CRAWFORD	40	11	141	N/A	WEIGH STATION			1	15	28	TYPICAL DIAMOND
4	CRAWFORD	40	11	147	13	71	67		1	52	69	TYPICAL DIAMOND
4	CRAWFORD	40	11	151	13	71	72		1	43	55	TYPICAL DIAMOND
4	CRAWFORD	40	11	171	20	CR 63	55		1	42	61	MODIFIED DIAMOND
4	CRAWFORD	40	11	175	20	CR 63	30		1	38	56	MODIFIED DIAMOND
4	CRAWFORD	40	11	182	24	215	18	9	1	52	61	MODIFIED DIAMOND
4	CRAWFORD	40	11	186	24	215	20	9	1	44	61	MODIFIED DIAMOND
4	CRAWFORD	40	11	812	N/A	WELCOME CENTER			1	6	18	MODIFIED DIAMOND
4	CRAWFORD	49	27	202	21	COLUM LN.	65		1	5	49	LOOP
4	CRAWFORD	49	27	203	21	COLLUM LN.	55		1	9	44	MODIFIED DIAMOND
4	CRAWFORD	49	27	205	24	282	26	18	1	21	22	MODIFIED DIAMOND
4	CRAWFORD	49	27	209	24	282	27	20	1	22	16	MODIFIED DIAMOND
4	CRAWFORD	49	27	213	29	282	14	12	1	16	14	TYPICAL DIAMOND
4	CRAWFORD	49	27	217	29	282	17	13	1	13	13	TYPICAL DIAMOND
4	CRAWFORD	49	27	224	34	282	22	12	1	21	36	LOOP
4	CRAWFORD	49	27	226	34	282	25	14	1	20	23	MODIFIED DIAMOND
4	CRAWFORD	540	2	179	3	N/A	18	14	1	25	36	TYPICAL DIAMOND
4	CRAWFORD	540	2	183	3	N/A	20	13	1	24	62	TYPICAL DIAMOND
SUBTOTALS CRAWFORD COUNTY:							673	160	24	629	986	
4	FRANKLIN	40	12	195	35	23	22	10	1	29	52	TYPICAL DIAMOND
4	FRANKLIN	40	12	199	35	23	20	10	1	34	58	TYPICAL DIAMOND
4	FRANKLIN	40	12	209	37	219	22	9	1	25	85	MODIFIED DIAMOND
4	FRANKLIN	40	12	214	37	219	22	9	1	25	72	MODIFIED DIAMOND
4	FRANKLIN	40	12	219	41	186	22	9	1	25	54	MODIFIED DIAMOND
4	FRANKLIN	40	12	224	41	186	22	9	1	25	54	MODIFIED DIAMOND
4	FRANKLIN	40	12	815	N/A	REST AREA			1	25	66	LOOP
4	FRANKLIN	40	12	818	N/A	REST AREA			1	21	34	TYPICAL DIAMOND
SUBTOTALS FRANKLIN COUNTY:							130	56	8	209	475	
4	SEBASTIAN	271	1	111	14	271	20	9	1	21	37	TYPICAL DIAMOND
4	SEBASTIAN	540	1	115	14	271	17	9	1	21	38	TYPICAL DIAMOND
4	SEBASTIAN	540	1	119	13	JENNY LIND RD.	19	9	1	20	41	TYPICAL DIAMOND
4	SEBASTIAN	540	1	124	13	JENNY LIND RD.	19	8	1	21	45	TYPICAL DIAMOND
4	SEBASTIAN	540	1	128	12	71	15	8	1	17	17	TYPICAL DIAMOND
4	SEBASTIAN	540	1	133	12	71	27	10	1	32	49	TYPICAL DIAMOND
4	SEBASTIAN	540	1	137	11	255	48		1	20	32	TYPICAL DIAMOND
4	SEBASTIAN	540	1	139	11	255	44		1	21	32	TYPICAL DIAMOND
4	SEBASTIAN	540	1	142	10	45	56		1	19	39	TYPICAL DIAMOND
4	SEBASTIAN	540	1	148	10	45	15	9	1	35	53	TYPICAL DIAMOND
4	SEBASTIAN	540	1	151	9	LEIGH AVE.	18		1	23	44	TYPICAL DIAMOND
4	SEBASTIAN	540	1	154	9	LEIGH AVE.	28	9	1	29	29	TYPICAL DIAMOND
4	SEBASTIAN	540	1	156	8	22	24	9	1	27	50	MODIFIED DIAMOND
4	SEBASTIAN	540	1	161	8A	22		11	1	54	73	TYPICAL DIAMOND
4	SEBASTIAN	540	1	164	8	22			1	10	54	LOOP
4	SEBASTIAN	540	1	165	6	GRAND AVE.	18		1	29	44	TYPICAL DIAMOND
4	SEBASTIAN	540	1	168	6	GRAND AVE.	24		1	22	32	TYPICAL DIAMOND
4	SEBASTIAN	540	1	173	5	KELLEY HWY.	38	21	1	31	52	TYPICAL DIAMOND
4	SEBASTIAN	540	1	176	5	KELLEY HWY.	20	12	1	21	41	TYPICAL DIAMOND
4	SEBASTIAN	549	6	212	187	71			1	61	61	TYPICAL DIAMOND
4	SEBASTIAN	549	6	439	190	MASSARD RD.	34	5	1	38	72	TYPICAL DIAMOND
4	SEBASTIAN	549	6	441	190	MASSARD RD.	35	6	1	40	75	TYPICAL DIAMOND
4	SEBASTIAN	549	6	443	191	ROBERTS BLVD.	31	5	1	30	65	TYPICAL DIAMOND
4	SEBASTIAN	549	6	445	191	ROBERTS BLVD.	35	6	1	32	78	TYPICAL DIAMOND
4	SEBASTIAN	549	6	452	193	22	16		1	49	84	LOOP
SUBTOTALS SEBASTIAN COUNTY:							601	146	25	616	1237	

NOTE: REFER TO SHS MANUAL FOR DIMENSIONS FOR THERMOPLASTIC WRONG-WAY PAVEMENT ARROWS, THERMOPLASTIC WRONG-WAY PAVEMENT ARROWS SHALL BE PAID FOR UNDER "THERMOPLASTIC PAVEMENT MARKING (ARROWS)".

DISTRICT 4  
QUANTITIES

DATE REVISED	DATE FILMED	DATE REVISED	DATE FILMED	FED. PROJ. NO.	STATE	FED. PROJ. NO.	SHEET NO.	TOTAL SHEETS
12/13/16				6	ARK.			
				JOB NO.	012260		22	61

2 QUANTITIES

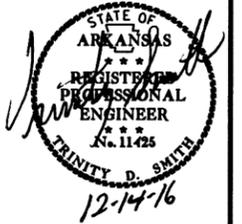

STOP LINES, WRONG-WAY ARROWS, AND RAMP DELINEATORS (BOX 2 OF 2)

DISTRICT	COUNTY	ROUTE	MAIN LANE SECTION	RAMP SECTION	EXIT NUMBER	CROSS ROAD	STOP LINES	YIELD LINES	THERMO. WRONG-WAY PAVEMENT ARROWS	DELINEATOR (TYPE 2) YELLOW	DELINEATOR (TYPE 2) WHITE	TYPE OF RAMP
							LIN. FT.	LIN. FT.	EACH	EACH	EACH	
4	WASHINGTON	49	28	231	45	74	25	16	1	36	36	MODIFIED DIAMOND
4	WASHINGTON	49	28	235	45	74	21	24	1	19	19	MODIFIED DIAMOND
4	WASHINGTON	49	28	239	53	156	16	24	1	25	25	MODIFIED DIAMOND
4	WASHINGTON	49	28	244	53	156	15	20	1	32	32	MODIFIED DIAMOND
4	WASHINGTON	49	28	248	58	WILSON ST.	22	13	1	12	12	TYPICAL DIAMOND
4	WASHINGTON	49	28	253	58	WILSON ST.	17	18	1	12	12	TYPICAL DIAMOND
4	WASHINGTON	49	28	257	60	112	16	14	1	24	24	MODIFIED DIAMOND
4	WASHINGTON	49	28	259	60	112	19	14	1	21	21	MODIFIED DIAMOND
4	WASHINGTON	49	28	267	62	62/180	44		1	13	13	MODIFIED DIAMOND
4	WASHINGTON	49	28	272	62	62/180	58			28	28	SLIP
4	WASHINGTON	49	28	281	64	16/112S	17	17	1	18	18	MODIFIED DIAMOND
4	WASHINGTON	49	28	284	64	16/112S	62		1	17	17	MODIFIED DIAMOND
4	WASHINGTON	49	28	287	65	PORTER RD.	38		1	9	9	TYPICAL DIAMOND
4	WASHINGTON	49	28	289	65	PORTER RD.	58		1	8	8	TYPICAL DIAMOND
4	WASHINGTON	49	28	292	66	112	*	*	*	*	*	MODIFIED DIAMOND
4	WASHINGTON	49	28	295	66	112	*	*	*	*	*	LOOP
4	WASHINGTON	49	28	301	69	JOHNSON MILL BLVD.	15	26	1	10	10	TYPICAL DIAMOND
4	WASHINGTON	49	28	305	69	JOHNSON MILL BLVD.	30	18	1	9	9	TYPICAL DIAMOND
4	WASHINGTON	49	28	306	70	DON TYSON PKWY.	58		1	15	27	LOOP
4	WASHINGTON	49	28	309	WEIGH STATION	WEIGH STATION			1	19	17	TYPICAL DIAMOND
4	WASHINGTON	49	28	310	70	DON TYSON PKWY.	34	22	1	17	22	LOOP
4	WASHINGTON	49	28	313	72	412	28	16	1	19	19	MODIFIED DIAMOND
4	WASHINGTON	49	28	317	72	412	35	20	1	9	9	TYPICAL DIAMOND
4	WASHINGTON	49	28	324	WEIGH STATION	WEIGH STATION			1	23	22	TYPICAL DIAMOND
4	WASHINGTON	49	28	326	73	ELM SPRINGS RD.	*	*	*	*	*	TYPICAL DIAMOND
4	WASHINGTON	49	28	332	73	ELM SPRINGS RD.	*	*	*	*	*	TYPICAL DIAMOND
4	WASHINGTON	71	16	111	60	112	19	14	1	22	17	MODIFIED DIAMOND
SUBTOTALS WASHINGTON COUNTY:							647	276	22	417	426	
TOTALS DISTRICT 4:							2051	638	79	1871	3124	

NOTE: REFER TO SHS MANUAL FOR DIMENSIONS FOR THERMOPLASTIC WRONG-WAY PAVEMENT ARROWS, THERMOPLASTIC WRONG-WAY PAVEMENT ARROWS SHALL BE PAID FOR UNDER "THERMOPLASTIC PAVEMENT MARKING (ARROWS)".  
 \* THESE LOCATIONS ARE CURRENTLY UNDER CONSTRUCTION AND WRONG-WAY DRIVING COUNTERMEASURES WILL BE ADDED TO THEIR JOB SCOPE

BARRIER WALL DELINEATORS

DISTRICT	COUNTY	ROUTE	SECTION	EXIT NO	CROSS ROAD	BARRIER LENGTH	NUMBER OF BARRIER WALL DELINEATORS
						LIN. FT.	EACH
4	CRAWFORD	49	27	21	COLLUM LN.	1589	30
4	CRAWFORD	49	27	21	COLLUM LN.	1805	28
4	CRAWFORD	49	27	34	HWY. 282	226	4
4	CRAWFORD	49	27	34	HWY. 282	709	16
4	CRAWFORD	540	2	3	HWY. 59	227	4
SUBTOTAL CRAWFORD COUNTY:							82
4	SEBASTIAN	540	1	8	HWY. 22/ROGERS AVE.	750	52
4	SEBASTIAN	540	1	8	HWY. 22/ROGERS AVE.	275	10
SUBTOTAL SEBASTIAN COUNTY:							62
4	WASHINGTON	49	28	70	DON TYSON PKWY.	353	5
4	WASHINGTON	49	28	70	DON TYSON PKWY.	394	9
SUBTOTAL WASHINGTON COUNTY:							14
TOTAL DISTRICT 4:							158

LANE USE ARROWS

DISTRICT	COUNTY	ROUTE	SECTION	DIRECTION	EXIT NO.	LANE USE ARROWS	TO
						EACH	
4	CRAWFORD	40	11	WB	1	2	DORA ROAD
TOTAL DISTRICT 4:						2	

NOTE: LANE USE ARROWS WILL BE PLACED IN A PAIR (AS SHOWN ON SHEET 6) TO SHOW THE CORRECT TRAFFIC MOVEMENT FOR VEHICLES EXITING THE FREEWAY AND VEHICLES ON THE FRONTAGE ROADS. THE CONTRACTOR SHALL PLACE THE ARROWS, ONE FOR EACH DIRECTION OF TRAVEL, ON TWO-WAY FRONTAGE ROADS DOWNSTREAM FROM A FREEWAY EXIT RAMP. SEE DETAIL ON SHEET NO. 6. LANE USE ARROWS SHALL BE PAID FOR UNDER "THERMOPLASTIC PAVEMENT MARKING (ARROWS)".

LANE EXTENSIONS

DISTRICT	COUNTY	ROUTE	MAIN LANE SECTION	RAMP SECTION	EXIT NO	CROSS ROAD	LENGTH OF LANE EXTENSION
							LIN. FT.
4	CRAWFORD	49	27	202	21	COLLUM LN.	90
4	CRAWFORD	49	27	204	21	COLLUM LN.	109
4	CRAWFORD	49	27	224	34	282	64
4	CRAWFORD	49	27	228	34	282	64
4	CRAWFORD	540	2	181	3	N/A	0
4	CRAWFORD	540	2	183	3	N/A	0
TOTAL CRAWFORD COUNTY:							327
4	WASHINGTON	49	28	295	66	112	85
4	WASHINGTON	49	28	295	66	112/GARLAND AVE.	*
4	WASHINGTON	49	28	306	70	DON TYSON PKWY.	94
4	WASHINGTON	49	28	310	70	DON TYSON PKWY.	84
4	WASHINGTON	71	17B	121		N. SHILOH DR./GREGG ST.	54
4	WASHINGTON	71	16	437	60	112/RAZORBADK RD.	80
TOTAL WASHINGTON COUNTY:							397
TOTAL DISTRICT 4:							724

NOTE: LANE EXTENSIONS SHALL BE DASHED, 4" WIDE, YELLOW PAVEMENT MARKINGS THAT GUIDE LEFT-TURNING TRAFFIC FROM THE CROSS ROAD TO THE CORRECT RAMP AT A FREEWAY INTERCHANGE. LANE EXTENSIONS SHALL BE PAID FOR UNDER "THERMOPLASTIC PAVEMENT MARKING YELLOW (6)".

\* THESE LOCATIONS ARE CURRENTLY UNDER CONSTRUCTION AND WRONG-WAY DRIVING COUNTERMEASURES WILL BE ADDED TO THEIR JOB SCOPE

DATE REVISED	DATE FILMED	DATE REVISED	DATE FILMED	FED. RD. DIST. NO.	STATE	FED. AID PROJ. NO.	SHEET NO.	TOTAL SHEETS
				6	ARK.			
							JOB NO. 012260	23 61

② QUANTITIES



DISTRICT 5  
WHITE COUNTY

ROUTE	SECT.	LOG MILE (EXIT NO.) DIRECTION	SIGNS	LOCATION AND SIZE			TOTAL SIGNS	
				LEFT	RIGHT	FAR RIGHT	NO.	SQ. FT.
67	12	28 N.B.	STOP	48"	48"		2	32.00
			YIELD			48"	1	7.00
			DO NOT ENTER	36"	36"	30"	2/1	24.25
			ONE WAY	(2) 18"x 54"	(2) 18"x 54"		4	27.00
			WRONG WAY	30"x 42"	30"x 42"		2	17.50
			KEEP RIGHT					
67	12	28 S.B.	STOP	48"	48"		2	32.00
			YIELD					
			DO NOT ENTER	36"	36"	30"	2/1	24.25
			ONE WAY	(2) 18"x 54"	(2) 18"x 54"		4	27.00
			WRONG WAY	30"x 42"	30"x 42"		2	17.50
			KEEP RIGHT					
67	12	29 N.B.	STOP	36"	36"		2	18.00
			YIELD			48"	1	7.00
			DO NOT ENTER	30"	30"	30"	3	18.75
			ONE WAY	(2) 12"x 36"	(2) 12"x 36"		4	12.00
			WRONG WAY	30"x 42"	30"x 42"		3	26.25
			KEEP RIGHT					
67	12	29 S.B.	STOP	48"	48"		3	48.00
			YIELD			48"	1	7.00
			DO NOT ENTER		36"	30"	1/1	15.25
			ONE WAY		(2) 18"x 54"		2	13.50
			WRONG WAY	30"x 42"	30"x 42"		2	17.50
			KEEP RIGHT	24"x 30"			1	5.00
67	12	31 N.B.	STOP	36"	36"		2	18.00
			YIELD			48"	1	7.00
			DO NOT ENTER	30"	30"	30"	3	18.75
			ONE WAY	(2) 12"x 36"	(2) 12"x 36"		4	12.00
			WRONG WAY	30"x 42"	30"x 42"		2	17.50
			KEEP RIGHT					
67	12	31 S.B.	STOP	36"	36"		2	18.00
			YIELD			48"	1	7.00
			DO NOT ENTER	30"	30"	30"	3	18.75
			ONE WAY	(2) 12"x 36"	(2) 12"x 36"		4	12.00
			WRONG WAY	30"x 42"	30"x 42"		2	17.50
			KEEP RIGHT					
<b>SUBTOTAL:</b>							<b>543.25</b>	

DISTRICT 5  
WHITE COUNTY

ROUTE	SECT.	LOG MILE (EXIT NO.) DIRECTION	SIGNS	LOCATION AND SIZE			TOTAL SIGNS	
				LEFT	RIGHT	FAR RIGHT	NO.	SQ. FT.
67	12	35 N.B.	STOP	36"	36"		2	18.00
			YIELD			48"	1	7.00
			DO NOT ENTER	30"	30"	30"	3	18.75
			ONE WAY	(2) 12"x 36"	(2) 12"x 36"		4	12.00
			WRONG WAY	30"x 42"	30"x 42"		2	17.50
			KEEP RIGHT					
67	12	35 S.B.	STOP	36"	36"		2	18.00
			YIELD			48"	1	7.00
			DO NOT ENTER	30"	30"	30"	3	18.75
			ONE WAY	(2) 12"x 36"	(2) 12"x 36"		4	12.00
			WRONG WAY	30"x 42"	30"x 42"		2	17.50
			KEEP RIGHT					
67	12	42 N.B.	STOP	36"	36"		2	18.00
			YIELD			48"	1	7.00
			DO NOT ENTER	30"	30"	30"	3	18.75
			ONE WAY	(2) 12"x 36"	(2) 12"x 36"		4	12.00
			WRONG WAY	30"x 42"	30"x 42"		2	17.50
			KEEP RIGHT					
67	12	42 S.B.	STOP	48"	48"		2	32.00
			YIELD					
			DO NOT ENTER	36"	36"	30"	2/1	24.25
			ONE WAY	(2) 18"x 54"	(2) 18"x 54"		4	27.00
			WRONG WAY	30"x 42"	30"x 42"		2	17.50
			KEEP RIGHT					
67	12	44 N.B.	STOP	36"	36"		2	18.00
			YIELD			48"	1	7.00
			DO NOT ENTER	30"	30"	30"	3	18.75
			ONE WAY	(2) 12"x 36"	(2) 12"x 36"		4	12.00
			WRONG WAY	30"x 42"	30"x 42"		2	17.50
			KEEP RIGHT					
67	12	44 S.B.	STOP	36"	36"		2	18.00
			YIELD			48"	1	7.00
			DO NOT ENTER	30"	30"	30"	3	18.75
			ONE WAY	(2) 12"x 36"	(2) 12"x 36"		4	12.00
			WRONG WAY	30"x 42"	30"x 42"		2	17.50
			KEEP RIGHT					
<b>SUBTOTAL:</b>							<b>467.00</b>	

DISTRICT 5  
WHITE COUNTY

ROUTE	SECT.	LOG MILE (EXIT NO.) DIRECTION	SIGNS	LOCATION AND SIZE			TOTAL SIGNS	
				LEFT	RIGHT	FAR RIGHT	NO.	SQ. FT.
67	12	45 N.B.	STOP	48"	48"		2	32.00
			YIELD			48"	1	7.00
			DO NOT ENTER	36"	36"	30"	2/1	24.25
			ONE WAY	(2) 18"x 54"	(2) 18"x 54"		4	27.00
			WRONG WAY	30"x 42"	30"x 42"		2	17.50
			KEEP RIGHT					
67	12	45 S.B.	STOP	48"	48"		2	32.00
			YIELD					
			DO NOT ENTER	36"	36"	30"	2/1	24.25
			ONE WAY	(2) 18"x 54"	(2) 18"x 54"		4	27.00
			WRONG WAY	30"x 42"	30"x 42"		2	17.50
			KEEP RIGHT					
67	12	46 N.B.	STOP			48"	1	7.00
			YIELD					
			DO NOT ENTER	36"	36"	30"	2/1	24.25
			ONE WAY	(2) 18"x 54"	(2) 18"x 54"		4	27.00
			WRONG WAY	30"x 42"	30"x 42"		2	17.50
			KEEP RIGHT					
67	13	46 S.B.	STOP	48"	48"		2	32.00
			YIELD			48"	1	7.00
			DO NOT ENTER	36"	36"	30"	2/1	24.25
			ONE WAY	(2) 18"x 54"	(2) 18"x 54"		4	27.00
			WRONG WAY	30"x 42"	30"x 42"		2	17.50
			KEEP RIGHT					
67	13	48 N.B.	STOP	36"	36"		2	18.00
			YIELD			48"	1	7.00
			DO NOT ENTER	30"	30"	30"	2/1	24.25
			ONE WAY	(2) 12"x 36"	(2) 12"x 36"		4	27.00
			WRONG WAY	30"x 42"	30"x 42"		2	17.50
			KEEP RIGHT					
67	13	48 S.B.	STOP	36"	36"		2	18.00
			YIELD			48"	1	7.00
			DO NOT ENTER	30"	30"	30"	2/1	24.25
			ONE WAY	(2) 12"x 36"	(2) 12"x 36"		4	27.00
			WRONG WAY	30"x 42"	30"x 42"		2	17.50
			KEEP RIGHT					
<b>SUBTOTAL:</b>							<b>579.50</b>	

NOTE: RED VERTICAL STRIPS SHALL BE PLACED ON ALL WRONG-WAY & DO NOT ENTER SIGN POSTS.

r012260.dgn Quantities

9/26/16

DATE REVISED	DATE FILMED	DATE REVISED	DATE FILMED	FED. RD. DIST. NO.	STATE	FED. AID PROJ. NO.	SHEET NO.	TOTAL SHEETS
				6	ARK.			
						JOB NO. 012260	24	61

② QUANTITIES



DISTRICT 5  
WHITE COUNTY

ROUTE	SECT.	LOG MILE (EXIT NO.) DIRECTION	SIGNS	LOCATION AND SIZE			TOTAL SIGNS	
				LEFT	RIGHT	FAR RIGHT	NO.	SQ. FT.
67	13	51 N.B.	STOP	36"	36"		2	18.00
			YIELD			48"	1	7.00
			DO NOT ENTER	30"	30"	30"	3	18.75
			ONE WAY	(2) 12"x 36"	(2) 12"x 36"		4	12.00
			WRONG WAY	30"x 42"	30"x 42"		2	17.50
			KEEP RIGHT					
67	13	51 S.B.	STOP	36"	36"		2	18.00
			YIELD			48"	1	7.00
			DO NOT ENTER	30"	30"	30"	3	18.75
			ONE WAY	(2) 12"x 36"	(2) 12"x 36"		4	12.00
			WRONG WAY	30"x 42"	30"x 42"		2	17.50
			KEEP RIGHT					
67	13	54 N.B.	STOP	36"	36"		2	18.00
			YIELD			48"	1	7.00
			DO NOT ENTER	30"	30"	30"	3	18.75
			ONE WAY	(2) 12"x 36"	(2) 12"x 36"		4	12.00
			WRONG WAY	30"x 42"	30"x 42"		2	17.50
			KEEP RIGHT					
67	13	54 S.B.	STOP	36"	36"		2	18.00
			YIELD			48"	1	7.00
			DO NOT ENTER	30"	30"	30"	3	18.75
			ONE WAY	(2) 12"x 36"	(2) 12"x 36"		4	12.00
			WRONG WAY	30"x 42"	30"x 42"		2	17.50
			KEEP RIGHT					
67	13	55 N.B.	STOP			48"	1	7.00
			DO NOT ENTER	36"	36"	30"	2/1	24.25
			ONE WAY	(2) 18"x 54"	(2) 18"x 54"		4	27.00
			WRONG WAY	30"x 42"	30"x 42"		2	17.50
			KEEP RIGHT					
67	13	55 S.B.	STOP	48"	48"		2	32.00
			YIELD			48"	1	7.00
			DO NOT ENTER	36"	36"	30"	2/1	24.25
			ONE WAY	(2) 18"x 54"	(2) 18"x 54"		4	27.00
			WRONG WAY	30"x 42"	30"x 42"		2	17.50
			KEEP RIGHT					
<b>SUBTOTAL:</b>								476.50

DISTRICT 5  
WHITE COUNTY

ROUTE	SECT.	LOG MILE (EXIT NO.) DIRECTION	SIGNS	LOCATION AND SIZE			TOTAL SIGNS	
				LEFT	RIGHT	FAR RIGHT	NO.	SQ. FT.
67	13	60 N.B.	STOP	36"	36"		2	18.00
			YIELD			48"	1	7.00
			DO NOT ENTER	30"	30"	30"	3	18.75
			ONE WAY	(2) 12"x 36"	(2) 12"x 36"		4	12.00
			WRONG WAY	30"x 42"	30"x 42"		2	17.50
			KEEP RIGHT					
67	13	60 S.B.	STOP	36"	36"		2	18.00
			YIELD			48"	1	7.00
			DO NOT ENTER	30"	30"	30"	3	18.75
			ONE WAY	(2) 12"x 36"	(2) 12"x 36"		4	12.00
			WRONG WAY	30"x 42"	30"x 42"		2	17.50
			KEEP RIGHT					
67	13	65 N.B.	STOP	36"	36"		2	18.00
			YIELD			48"	1	7.00
			DO NOT ENTER	30"	30"	30"	3	18.75
			ONE WAY	(2) 12"x 36"	(2) 12"x 36"		4	12.00
			WRONG WAY	30"x 42"	30"x 42"		2	17.50
			KEEP RIGHT					
67	13	65 S.B.	STOP	36"	36"		2	18.00
			YIELD			48"	1	7.00
			DO NOT ENTER	30"	30"	30"	3	18.75
			ONE WAY	(2) 12"x 36"	(2) 12"x 36"		4	12.00
			WRONG WAY	30"x 42"	30"x 42"		2	17.50
			KEEP RIGHT					
<b>SUBTOTAL:</b>								293.00
<b>TOTAL WHITE COUNTY:</b>								2359.25

NOTE: RED VERTICAL STRIPS SHALL BE PLACED ON ALL WRONG-WAY & DO NOT ENTER SIGN POSTS.

DATE REVISED	DATE FILED	DATE REVISED	DATE FILED	FED. PROJ. NO.	STATE	FED. PROJ. NO.	SHEET NO.	TOTAL SHEETS
				6	ARK.			
JOB NO.						012260	25	61

② QUANTITIES



DISTRICT 5  
JACKSON COUNTY

ROUTE	SECT.	LOG MILE (EXIT NO.) DIRECTION	SIGNS	LOCATION AND SIZE			TOTAL SIGNS	
				LEFT	RIGHT	FAR RIGHT	NO.	SQ. FT.
67	14	69 N.B.	STOP	36"	36"		2	18.00
			YIELD			48"	1	7.00
			DO NOT ENTER	30"	30"	30"	3	18.75
			ONE WAY	(2) 12"x 36"	(2) 12"x 36"		4	12.00
			WRONG WAY	30"x 42"	30"x 42"		2	17.50
			KEEP RIGHT					
67	14	69 S.B.	STOP	36"	36"		2	18.00
			YIELD			48"	1	7.00
			DO NOT ENTER	30"	30"	30"	3	18.75
			ONE WAY	(2) 12"x 36"	(2) 12"x 36"		4	12.00
			WRONG WAY	30"x 42"	30"x 42"		2	17.50
			KEEP RIGHT					
67	14	74 N.B.	STOP	36"	36"		2	18.00
			YIELD			48"	1	7.00
			DO NOT ENTER	30"	30"	30"	3	18.75
			ONE WAY	(2) 12"x 36"	(2) 12"x 36"		4	12.00
			WRONG WAY	30"x 42"	30"x 42"		2	17.50
			KEEP RIGHT					
67	14	74 S.B.	STOP	36"	36"		2	18.00
			YIELD			48"	1	7.00
			DO NOT ENTER	30"	30"	30"	3	18.75
			ONE WAY	(2) 12"x 36"	(2) 12"x 36"		4	12.00
			WRONG WAY	30"x 42"	30"x 42"		2	17.50
			KEEP RIGHT					
67	14	80 N.B.	STOP	36"	36"		2	18.00
			YIELD			48"	1	7.00
			DO NOT ENTER	30"	30"	30"	3	18.75
			ONE WAY	(2) 12"x 36"	(2) 12"x 36"		4	12.00
			WRONG WAY	30"x 42"	30"x 42"		2	17.50
			KEEP RIGHT					
67	14	80 S.B.	STOP	36"	36"		2	18.00
			YIELD			48"	1	7.00
			DO NOT ENTER	30"	30"	30"	3	18.75
			ONE WAY	(2) 12"x 36"	(2) 12"x 36"		4	12.00
			WRONG WAY	30"x 42"	30"x 42"		2	17.50
			KEEP RIGHT					
<b>SUBTOTAL:</b>							<b>439.50</b>	

DISTRICT 5  
JACKSON COUNTY

ROUTE	SECT.	LOG MILE (EXIT NO.) DIRECTION	SIGNS	LOCATION AND SIZE			TOTAL SIGNS	
				LEFT	RIGHT	FAR RIGHT	NO.	SQ. FT.
67	14	82 N.B.	STOP	36"	36"		2	18.00
			YIELD			48"	1	7.00
			DO NOT ENTER	30"	30"	30"	3	18.75
			ONE WAY	(2) 12"x 36"	(2) 12"x 36"		4	12.00
			WRONG WAY	30"x 42"	30"x 42"		2	17.50
			KEEP RIGHT					
67	15	82 S.B.	STOP	36"	36"		2	18.00
			YIELD			48"	1	7.00
			DO NOT ENTER	30"	30"	30"	3	18.75
			ONE WAY	(2) 12"x 36"	(2) 12"x 36"		4	12.00
			WRONG WAY	30"x 42"	30"x 42"		2	17.50
			KEEP RIGHT					
67	15	83 N.B.	STOP	36"	36"		2	18.00
			YIELD			48"	1	7.00
			DO NOT ENTER	30"	30"	30"	3	18.75
			ONE WAY	(2) 12"x 36"	(2) 12"x 36"		4	12.00
			WRONG WAY	30"x 42"	30"x 42"		2	17.50
			KEEP RIGHT					
67	15	83 S.B.	STOP	36"	36"		2	18.00
			YIELD			48"	1	7.00
			DO NOT ENTER	30"	30"	30"	3	18.75
			ONE WAY	(2) 12"x 36"	(2) 12"x 36"		4	12.00
			WRONG WAY	30"x 42"	30"x 42"		2	17.50
			KEEP RIGHT					
67	15	85 N.B.	STOP	36"	36"		2	18.00
			YIELD			48"	1	7.00
			DO NOT ENTER	30"	30"	30"	3	18.75
			ONE WAY	(2) 12"x 36"	(2) 12"x 36"		4	12.00
			WRONG WAY	30"x 42"	30"x 42"		2	17.50
			KEEP RIGHT					
67	15	85 S.B.	STOP	36"	36"		2	18.00
			YIELD			48"	1	7.00
			DO NOT ENTER	30"	30"	30"	3	18.75
			ONE WAY	(2) 12"x 36"	(2) 12"x 36"		4	12.00
			WRONG WAY	30"x 42"	30"x 42"		2	17.50
			KEEP RIGHT					
<b>SUBTOTAL:</b>							<b>439.50</b>	

DISTRICT 5  
JACKSON COUNTY

ROUTE	SECT.	LOG MILE (EXIT NO.) DIRECTION	SIGNS	LOCATION AND SIZE			TOTAL SIGNS	
				LEFT	RIGHT	FAR RIGHT	NO.	SQ. FT.
67	15	87 N.B.	STOP	36"	36"		2	18.00
			YIELD			48"	1	7.00
			DO NOT ENTER	30"	30"	30"	3	18.75
			ONE WAY	(2) 12"x 36"	(2) 12"x 36"		4	12.00
			WRONG WAY	30"x 42"	30"x 42"		2	17.50
			KEEP RIGHT					
67	15	87 S.B.	STOP	36"	36"		2	18.00
			YIELD			48"	1	7.00
			DO NOT ENTER	30"	30"	30"	3	18.75
			ONE WAY	(2) 12"x 36"	(2) 12"x 36"		4	12.00
			WRONG WAY	30"x 42"	30"x 42"		2	17.50
			KEEP RIGHT					
67	15	95 N.B.	STOP	36"	36"		2	18.00
			YIELD			48"	1	7.00
			DO NOT ENTER	30"	30"	30"	3	18.75
			ONE WAY	(2) 12"x 36"	(2) 12"x 36"		4	12.00
			WRONG WAY	30"x 42"	30"x 42"		2	17.50
			KEEP RIGHT					
67	15	95 S.B.	STOP	36"	36"		2	18.00
			YIELD			48"	1	7.00
			DO NOT ENTER	30"	30"	30"	3	18.75
			ONE WAY	(2) 12"x 36"	(2) 12"x 36"		4	12.00
			WRONG WAY	30"x 42"	30"x 42"		2	17.50
			KEEP RIGHT					
<b>SUBTOTAL:</b>							<b>293.00</b>	
<b>TOTAL JACKSON COUNTY:</b>							<b>1172.00</b>	
<b>TOTAL DISTRICT 5:</b>							<b>3531.25</b>	

NOTE: RED VERTICAL STRIPS SHALL BE PLACED ON ALL WRONG-WAY & DO NOT ENTER SIGN POSTS.

DATE REVISED	DATE FILMED	DATE REVISED	DATE FILMED	FED. DIST. NO.	STATE	FED. PROJ. NO.	SHEET NO.	TOTAL SHEETS
12/13/16				6	ARK.			
							JOB NO. 012260	26 61

② QUANTITIES



STOP LINES, WRONG-WAY ARROWS, AND RAMP DELINEATORS

DISTRICT	COUNTY	ROUTE	MAIN LANE SECTION	RAMP SECTION	EXIT NUMBER	CROSS ROAD	STOP LINES	YIELD LINES	THERMO. WRONG-WAY PAVEMENT ARROWS	DELINEATOR (TYPE 2) YELLOW	DELINEATOR (TYPE 2) WHITE	TYPE OF RAMP
							LIN. FT.	LIN. FT.	EACH	EACH	EACH	
5	JACKSON	67	14	398	69	JACKSON 315	20	18	1	21	21	TYPICAL DIAMOND
5	JACKSON	67	14	403	69	JACKSON 315	20	18	1	21	21	TYPICAL DIAMOND
5	JACKSON	67	14	408	74	224	20	18	1	25	25	TYPICAL DIAMOND
5	JACKSON	67	14	412	74	224	20	16	1	25	25	TYPICAL DIAMOND
5	JACKSON	67	14	417	80	14	28	20	1	26	26	TYPICAL DIAMOND
5	JACKSON	67	14	422	80	14	25	18	1	24	24	TYPICAL DIAMOND
5	JACKSON	67	14	426	82	17	18	16	1	23	23	TYPICAL DIAMOND
5	JACKSON	67	14	431	82	17	18	16	1	23	23	TYPICAL DIAMOND
5	JACKSON	67	14	436	83	384	24	18	1	25	25	TYPICAL DIAMOND
5	JACKSON	67	14	441	83	384	24	18	1	26	26	TYPICAL DIAMOND
5	JACKSON	67	14	445	85	18	25	20	1	25	25	TYPICAL DIAMOND
5	JACKSON	67	14	449	85	18	22	20	1	26	26	TYPICAL DIAMOND
5	JACKSON	67	14	454	87	CR 43	24	20	1	23	23	TYPICAL DIAMOND
5	JACKSON	67	14	458	87	CR 43	24	18	1	27	27	TYPICAL DIAMOND
5	JACKSON	67	14	463	95	37	22	18	1	25	25	TYPICAL DIAMOND
5	JACKSON	67	14	467	95	37	22	18	1	26	26	TYPICAL DIAMOND
<b>SUBTOTALS JACKSON COUNTY:</b>							<b>356</b>	<b>290</b>	<b>16</b>	<b>391</b>	<b>391</b>	
5	WHITE	67	12	241	28	HWY. 64	17	28	1	26	26	MODIFIED DIAMOND
5	WHITE	67	12	245	28	HWY. 64	31	30	1	27	27	MODIFIED DIAMOND
5	WHITE	67	12	252	29	HWY. 367S	26	30	1	30	30	TYPICAL DIAMOND
5	WHITE	67	12	501	29	HWY. 367S	24	30	1	35	35	TYPICAL DIAMOND
5	WHITE	67	12	255	31	HWY. 67B/31	21	28	1	24	24	TYPICAL DIAMOND
5	WHITE	67	12	259	31	HWY. 67B/33	28	34	1	26	26	TYPICAL DIAMOND
5	WHITE	67	12	265	35	HWY. 13	34	34	1	22	22	TYPICAL DIAMOND
5	WHITE	67	12	269	35	HWY. 13	36	34	1	22	22	TYPICAL DIAMOND
5	WHITE	67	12	275	42	HWY. 67B/367	31	36	1	27	27	TYPICAL DIAMOND
5	WHITE	67	12	279	42	HWY. 67B/367	36	36	1	28	28	TYPICAL DIAMOND
5	WHITE	67	12	287	44	HWY. 367	23	28	1	26	26	TYPICAL DIAMOND
5	WHITE	67	12	292	44	HWY. 367	23	30	1	25	25	TYPICAL DIAMOND
5	WHITE	67	12	296	45	HWY. 36	21	30	1	30	30	TYPICAL DIAMOND
5	WHITE	67	12	301	45	HWY. 36	31	28	1	26	26	TYPICAL DIAMOND
5	WHITE	67	12	305	46	HWY. 67C/36	21	21	1	28	28	TYPICAL DIAMOND
5	WHITE	67	13	309	46	HWY. 67C/36	25	17	1	34	34	TYPICAL DIAMOND
5	WHITE	67	13	314	48	HWY. 385	21	15	1	32	32	TYPICAL DIAMOND
5	WHITE	67	13	318	48	HWY. 385	19	15	1	32	32	TYPICAL DIAMOND
5	WHITE	67	13	341	51	HWY. 157	17	17	1	32	32	TYPICAL DIAMOND
5	WHITE	67	13	345	51	HWY. 157	22	16	1	31	31	TYPICAL DIAMOND
5	WHITE	67	13	359	54	BALD KNOB LAKE RD.	20	17	1	29	29	TYPICAL DIAMOND
5	WHITE	67	13	364	54	BALD KNOB LAKE RD.	22	17	1	33	33	TYPICAL DIAMOND
5	WHITE	67	13	368	55	HWY. 64/167	21	17	1	30	30	TYPICAL DIAMOND
5	WHITE	67	13	373	55	HWY. 64/167	21	16	1	31	31	TYPICAL DIAMOND
5	WHITE	67	13	378	60	3rd ST.	22	15	1	33	33	TYPICAL DIAMOND
5	WHITE	67	13	383	60	3rd ST.	21	15	1	31	31	TYPICAL DIAMOND
5	WHITE	67	13	388	65	HWY. 87	27	18	1	34	34	TYPICAL DIAMOND
5	WHITE	67	13	393	65	HWY. 87	23	20	1	32	32	TYPICAL DIAMOND
<b>SUBTOTALS WHITE COUNTY:</b>							<b>684</b>	<b>672</b>	<b>28</b>	<b>816</b>	<b>816</b>	
<b>TOTALS DISTRICT 5:</b>							<b>1040</b>	<b>962</b>	<b>44</b>	<b>1207</b>	<b>1207</b>	

NOTE: REFER TO SHS MANUAL FOR DIMENSIONS FOR THERMOPLASTIC WRONG-WAY PAVEMENT ARROWS, THERMOPLASTIC WRONG-WAY PAVEMENT ARROWS SHALL BE PAID FOR UNDER "THERMOPLASTIC PAVEMENT MARKING (ARROWS)".

LANE EXTENSIONS

DISTRICT	COUNTY	ROUTE	MAIN LANE SECTION	RAMP SECTION	EXIT NO	CROSS ROAD	LENGTH OF LANE EXTENSION
							LIN. FT.
5	WHITE	67	12	254	29	HWY. 367S	34
<b>TOTAL DISTRICT 5:</b>							<b>34</b>

NOTE: LANE EXTENSIONS SHALL BE DASHED, 4" WIDE, YELLOW PAVEMENT MARKINGS THAT GUIDE LEFT-TURNING TRAFFIC FROM THE CROSS ROAD TO THE CORRECT RAMP AT A FREEWAY INTERCHANGE. LANE EXTENSIONS SHALL BE PAID FOR UNDER "THERMOPLASTIC PAVEMENT MARKING YELLOW (6)".

BARRIER WALL DELINEATORS

DISTRICT	COUNTY	ROUTE	SECTION	EXIT NO	CROSS ROAD	BARRIER LENGTH	NUMBER OF BARRIER WALL DELINEATORS
						LIN. FT.	EACH
5	WHITE	67	12	29	ASU BLVD.	590	120
<b>TOTAL DISTRICT 5:</b>							<b>120</b>

② QUANTITIES



DISTRICT 6  
HOT SPRING COUNTY

ROUTE	SECT.	LOG MILE (EXIT NO.) DIRECTION	SIGNS	LOCATION AND SIZE			TOTAL SIGNS	
				LEFT	RIGHT	FAR RIGHT	NO.	SQ. FT.
30	21	83 E.B.	STOP	36"	36"		2	18.00
			YIELD			48"	1	7.00
			DO NOT ENTER	30"	30"	30"	3	18.75
			ONE WAY	(2) 12"x 36"	(2) 12"x 36"		4	12.00
			WRONG WAY	30"x 42"	30"x 42"		2	17.50
30	21	83 W.B.	STOP	36"	36"		2	18.00
			YIELD			48"	1	7.00
			DO NOT ENTER	30"	30"	30"	3	18.75
			ONE WAY	(2) 12"x 36"	(2) 12"x 36"		4	12.00
			WRONG WAY	30"x 42"	30"x 42"		2	17.50
30	21	91 E.B.	STOP	36"	36"		2	18.00
			YIELD					
			DO NOT ENTER	30"	30"		2	12.50
			ONE WAY	(2) 12"x 36"	(2) 12"x 36"		4	12.00
			WRONG WAY	30"x 42"	30"x 42"		2	17.50
30	21	91 W.B.	STOP	48"	48"		2	32.00
			YIELD					
			DO NOT ENTER		36"		1	9.00
			ONE WAY		(2) 18"x 54"		2	13.50
			WRONG WAY	30"x 42"	30"x 42"		2	17.50
30	21	97 E.B.	STOP	36"	36"		2	18.00
			YIELD			48"	1	7.00
			DO NOT ENTER	30"	30"	30"	3	18.75
			ONE WAY	(2) 12"x 36"	(2) 12"x 36"		4	12.00
			WRONG WAY	30"x 42"	30"x 42"		2	17.50
30	21	97 W.B.	STOP	36"	36"		2	18.00
			YIELD			48"	1	7.00
			DO NOT ENTER	30"	30"	30"	3	18.75
			ONE WAY	(2) 12"x 36"	(2) 12"x 36"		4	12.00
			WRONG WAY	30"x 42"	30"x 42"		2	17.50
SUBTOTAL:								430.00

DISTRICT 6  
HOT SPRING COUNTY

ROUTE	SECT.	LOG MILE (EXIT NO.) DIRECTION	SIGNS	LOCATION AND SIZE			TOTAL SIGNS	
				LEFT	RIGHT	FAR RIGHT	NO.	SQ. FT.
30	21	98A E.B.	STOP					
			YIELD					
			DO NOT ENTER	36"	36"		2	18.00
			ONE WAY	(2) 18"x 54"	(2) 18"x 54"		4	27.00
			WRONG WAY	30"x 42"	30"x 42"		2	17.50
			KEEP RIGHT					
30	21	98B E.B.	STOP					
			YIELD		48"		1	7.00
			DO NOT ENTER	36"	36"		2	18.00
			ONE WAY	(2) 18"x 54"	(2) 18"x 54"		4	27.00
			WRONG WAY	30"x 42"	30"x 42"		2	17.50
			KEEP RIGHT					
30	21	98A W.B.	STOP					
			YIELD		48"		1	7.00
			DO NOT ENTER	36"	36"		2	18.00
			ONE WAY	(2) 18"x 54"	(2) 18"x 54"		4	27.00
			WRONG WAY	30"x 42"	30"x 42"		2	17.50
			KEEP RIGHT					
30	21	98B W.B.	STOP					
			YIELD		48"		1	7.00
			DO NOT ENTER	36"	36"		2	18.00
			ONE WAY	(2) 18"x 54"	(2) 18"x 54"		4	27.00
			WRONG WAY	30"x 42"	30"x 42"		2	17.50
			KEEP RIGHT					
30	21	99 E.B.	STOP	36"	36"		2	18.00
			YIELD			48"	1	7.00
			DO NOT ENTER	30"	30"	30"	3	18.75
			ONE WAY	(2) 12"x 36"	(2) 12"x 36"		4	12.00
			WRONG WAY	30"x 42"	30"x 42"		2	17.50
			KEEP RIGHT					
30	21	99 W.B.	STOP	36"	36"		2	18.00
			YIELD					
			DO NOT ENTER	30"	30"		2	12.50
			ONE WAY	(2) 12"x 36"	(2) 12"x 36"		4	12.00
			WRONG WAY	30"x 42"	30"x 42"		2	17.50
			KEEP RIGHT					
SUBTOTAL:								404.25
TOTAL HOT SPRING COUNTY								834.25

DISTRICT 6  
SALINE COUNTY

ROUTE	SECT.	LOG MILE (EXIT NO.) DIRECTION	SIGNS	LOCATION AND SIZE			TOTAL SIGNS	
				LEFT	RIGHT	FAR RIGHT	NO.	SQ. FT.
30	22	106 E.B.	STOP	36"	36"		2	18.00
			YIELD			48"	1	7.00
			DO NOT ENTER	30"	30"	30"	3	18.75
			ONE WAY	(2) 12"x 36"	(2) 12"x 36"		4	12.00
			WRONG WAY	30"x 42"	30"x 42"		2	17.50
			KEEP RIGHT					
30	22	106 W.B.	STOP	36"	36"		2	18.00
			YIELD			48"	1	7.00
			DO NOT ENTER	30"	30"	30"	3	18.75
			ONE WAY	(2) 12"x 36"	(2) 12"x 36"		4	12.00
			WRONG WAY	30"x 42"	30"x 42"		2	17.50
			KEEP RIGHT					
530	2	12 N.B.	STOP	36"	36"		2	18.00
			YIELD			48"	1	7.00
			DO NOT ENTER	30"	30"	30"	3	18.75
			ONE WAY	(2) 12"x 36"	(2) 12"x 36"		4	12.00
			WRONG WAY	30"x 42"	30"x 42"		2	17.50
			KEEP RIGHT					
530	2	12 S.B.	STOP	36"	36"		2	18.00
			YIELD			48"	1	7.00
			DO NOT ENTER	30"	30"	30"	3	18.75
			ONE WAY	(2) 12"x 36"	(2) 12"x 36"		4	12.00
			WRONG WAY	30"x 42"	30"x 42"		2	17.50
			KEEP RIGHT					
TOTAL SALINE COUNTY:								293.00

\* ON INTERSECTING ROADWAY. ON ALL SLIP RAMPS TO TWO-WAY FRONTAGE ROADS, (2) 48" W6-3 SIGNS ARE REQUIRED ON THE FRONTAGE ROAD JUST BEYOND THE RAMP. I-30 EXITS 116WB, 117, 118, 121, 123, AND 126 ARE ALL SLIP RAMPS ONTO A ONE-WAY FRONTAGE ROAD AND ARE NOT SUBJECT TO THE REQUIREMENTS OF SECTION 2B.41.

NOTE: RED VERTICAL STRIPS SHALL BE PLACED ON ALL WRONG-WAY & DO NOT ENTER SIGN POSTS.

DATE REVISED	DATE FILMED	DATE REVISED	DATE FILMED	FED. RD. DIST. NO.	STATE	FED. AID PROJ. NO.	SHEET NO.	TOTAL SHEETS
				6	ARK.			
JOB NO. 012260							28	61

② QUANTITIES



DISTRICT 6  
PULASKI COUNTY

ROUTE	SECT.	LOG MILE (EXIT NO.) DIRECTION	SIGNS	LOCATION AND SIZE			TOTAL SIGNS	
				LEFT	RIGHT	FAR RIGHT	NO.	SQ. FT.
30	23	132 E.B.	STOP			48"	1	7.00
			YIELD					
			DO NOT ENTER		36"	30"	1/1	15.25
			ONE WAY		(2) 18"x 54"		2	13.50
			WRONG WAY	30"x 42"	30"x 42"		2	17.50
			KEEP RIGHT	24"x 30"			1	5.00
30	23	132 W.B.	STOP			48"	1	7.00
			YIELD					
			DO NOT ENTER		36"	30"	1/1	15.25
			ONE WAY		(2) 18"x 54"		2	13.50
			WRONG WAY	30"x 42"	30"x 42"		2	17.50
			KEEP RIGHT	24"x 30"			1	5.00
30	23	133 E.B.	STOP			48"	1	7.00
			YIELD			48"	1	7.00
			DO NOT ENTER	48"		48"	2	32.00
			ONE WAY	(2) 18"x 54"	(2) 18"x 54"		4	27.00
			WRONG WAY	30"x 42"	30"x 42"		2	17.50
			KEEP RIGHT					
30	23	133 W.B.	STOP			48"	1	7.00
			YIELD			48"	1	7.00
			DO NOT ENTER	48"		48"	2	32.00
			ONE WAY	(2) 18"x 54"	(2) 18"x 54"		4	27.00
			WRONG WAY	30"x 42"	30"x 42"		2	17.50
			KEEP RIGHT					
30	23	135 E.B.	STOP			48"	1	7.00
			YIELD			48"	1	7.00
			DO NOT ENTER	36"	48"	30"	1/1/1	31.25
			ONE WAY	(2) 18"x 54"	(2) 18"x 54"		4	27.00
			WRONG WAY	30"x 42"	30"x 42"		2	17.50
			KEEP RIGHT					
30	23	135 W.B.	STOP			48"	1	7.00
			YIELD			48"	1	7.00
			DO NOT ENTER	36"	48"	30"	1/1/1	31.25
			ONE WAY	(2) 18"x 54"	(2) 18"x 54"		4	27.00
			WRONG WAY	30"x 42"	30"x 42"		2	17.50
			KEEP RIGHT					
<b>SUBTOTAL:</b>							<b>404.50</b>	

I-30 EXITS 128, 129, 130, 131, 134, 139, 140, 141, AND 142 ARE ALL SLIP RAMPS ONTO A ONE-WAY FRONTAGE ROAD AND ARE NOT SUBJECT TO THE REQUIREMENTS OF SECTION 2B.41.

DISTRICT 6  
PULASKI COUNTY

ROUTE	SECT.	LOG MILE (EXIT NO.) DIRECTION	SIGNS	LOCATION AND SIZE			TOTAL SIGNS	
				LEFT	RIGHT	FAR RIGHT	NO.	SQ. FT.
40	33	142 E.B.	STOP	48"	48"		2	32.00
			YIELD			48"	1	7.00
			DO NOT ENTER	36"	36"	30"	2/1	24.25
			ONE WAY	(2) 18"x 54"	(2) 18"x 54"		4	27.00
			WRONG WAY	30"x 42"	30"x 42"		2	17.50
			KEEP RIGHT					
40	33	142 W.B.	STOP			48"	1	7.00
			YIELD			48"	1	7.00
			DO NOT ENTER	36"	36"	30"	2/1	24.25
			ONE WAY	(2) 18"x 54"	(2) 18"x 54"		4	27.00
			WRONG WAY	30"x 42"	30"x 42"		2	17.50
			KEEP RIGHT					
40	33	148 E.B.	STOP	48"	48"		2	32.00
			YIELD			48"	1	7.00
			DO NOT ENTER	36"	36"	30"	2/1	24.25
			ONE WAY	(2) 18"x 54"	(2) 18"x 54"		4	27.00
			WRONG WAY	30"x 42"	30"x 42"		2	17.50
			KEEP RIGHT					
40	33	148 W.B.	STOP	48"	48"		2	32.00
			YIELD			48"	1	7.00
			DO NOT ENTER	36"	36"	30"	2/1	24.25
			ONE WAY	(2) 18"x 54"	(2) 18"x 54"		4	27.00
			WRONG WAY	30"x 42"	30"x 42"		2	17.50
			KEEP RIGHT					
40	33	150 E.B.	STOP	36"	36"		2	18.00
			YIELD			48"	1	7.00
			DO NOT ENTER	30"	30"	30"	3	18.75
			ONE WAY	(2) 12"x 36"	(2) 12"x 36"		4	12.00
			WRONG WAY	30"x 42"	30"x 42"		2	17.50
			KEEP RIGHT					
40	33	150 W.B.	STOP	48"	48"		2	32.00
			YIELD			48"	1	7.00
			DO NOT ENTER		36"	30"	1/1	15.25
			ONE WAY		(2) 18"x 54"		2	13.50
			WRONG WAY	30"x 42"	30"x 42"		2	17.50
			KEEP RIGHT	24"x 30"			1	5.00
<b>SUBTOTAL:</b>							<b>562.50</b>	

DISTRICT 6  
PULASKI COUNTY

ROUTE	SECT.	LOG MILE (EXIT NO.) DIRECTION	SIGNS	LOCATION AND SIZE			TOTAL SIGNS		
				LEFT	RIGHT	FAR RIGHT	NO.	SQ. FT.	
40	33	152 E.B.	STOP		36"	36"		2	18.00
			YIELD			48"	1	7.00	
			DO NOT ENTER	30"	30"	30"	3	18.75	
			ONE WAY	(2) 12"x 36"	(2) 12"x 36"		4	12.00	
			WRONG WAY	30"x 42"	30"x 42"		2	17.50	
			KEEP RIGHT						
40	33	152A W.B.	STOP			48"	1	7.00	
			YIELD			48"	1	7.00	
			DO NOT ENTER	30"	30"	30"	3	18.75	
			ONE WAY	(2) 12"x 36"	(2) 12"x 36"		4	12.00	
			WRONG WAY	30"x 42"	30"x 42"		2	17.50	
			KEEP RIGHT						
40	33	152B W.B.	STOP						
			YIELD						
			DO NOT ENTER		36"		1	9.00	
			ONE WAY		(2) 18"x 54"		2	13.50	
			WRONG WAY	30"x 42"	30"x 42"		2	17.50	
			KEEP RIGHT	24"x 30"			1	5.00	
40	33	156 E.B.	STOP						
			YIELD						
			DO NOT ENTER						
			ONE WAY						
			WRONG WAY	30"x 42"	30"x 42"		2	17.50	
			KEEP RIGHT						
40	33	156 W.B.	STOP						
			YIELD						
			DO NOT ENTER	36"	36"		2	18.00	
			ONE WAY						
			WRONG WAY	30"x 42"	30"x 42"		2	17.50	
			KEEP RIGHT						
40	33	157 E.B.	STOP						
			YIELD						
			DO NOT ENTER	36"	36"		2	18.00	
			ONE WAY	(2) 18"x 54"	(2) 18"x 54"		4	27.00	
			WRONG WAY	30"x 42"	30"x 42"		2	17.50	
			KEEP RIGHT						
<b>SUBTOTAL:</b>							<b>289.00</b>		

I-40 EXITS 153 AND 154 ARE SLIP RAMPS ONTO A ONE-WAY FRONTAGE ROAD AND ARE NOT SUBJECT TO THE REQUIREMENTS OF SECTION 2B.41.

NOTE: RED VERTICAL STRIPS SHALL BE PLACED ON ALL WRONG-WAY & DO NOT ENTER SIGN POSTS.

DATE REVISED	DATE FILMED	DATE REVISED	DATE FILMED	FED. RD. DIST. NO.	STATE	FED. AID PROJ. NO.	SHEET NO.	TOTAL SHEETS
12/13/16				6	ARK.		29	61
				JOB NO.		012260		

2 QUANTITIES



DISTRICT 6  
PULASKI COUNTY

ROUTE	SECT.	LOG MILE (EXIT NO.) DIRECTION	SIGNS	LOCATION AND SIZE			TOTAL SIGNS	
				LEFT	RIGHT	FAR RIGHT	NO.	SQ. FT.
40	33	157 W.B.	STOP					
			YIELD					
			DO NOT ENTER	36"	36"		2	18.00
			ONE WAY	(2) 18"x 54"	(2) 18"x 54"		4	27.00
			WRONG WAY	30"x 42"	30"x 42"		2	17.50
KEEP RIGHT								
40	33	161 E.B.	STOP	48"	48"		2	32.00
			YIELD					
			DO NOT ENTER	36"	36"		2	18.00
			ONE WAY	(2) 18"x 54"	(2) 18"x 54"		4	27.00
			WRONG WAY	30"x 42"	30"x 42"		2	17.50
KEEP RIGHT								
40	33	161 W.B.	STOP	48"	48"		2	32.00
			YIELD					
			DO NOT ENTER		36"		1	9.00
			ONE WAY		(2) 18"x 54"		2	13.50
			WRONG WAY	30"x 42"	30"x 42"		2	17.50
KEEP RIGHT	24"x 30"			1	5.00			
40	33	148 W.B.	STOP	48"	48"		2	32.00
			YIELD			48"	1	7.00
			DO NOT ENTER	36"	36"	30"	2/1	24.25
			ONE WAY	(2) 18"x 54"	(2) 18"x 54"		4	27.00
			WRONG WAY	30"x 42"	30"x 42"		2	17.50
KEEP RIGHT								
40	33	150 E.B.	STOP	36"	36"		2	18.00
			YIELD			48"	1	7.00
			DO NOT ENTER	30"	30"	30"	3	18.75
			ONE WAY	(2) 12"x 36"	(2) 12"x 36"		4	12.00
			WRONG WAY	30"x 42"	30"x 42"		2	17.50
KEEP RIGHT								
40	33	150 W.B.	STOP	48"	48"		2	32.00
			YIELD			48"	1	8.00
			DO NOT ENTER		36"	30"	1/1	15.25
			ONE WAY		(2) 18"x 54"		2	13.50
			WRONG WAY	30"x 42"	30"x 42"		2	17.50
KEEP RIGHT	24"x 30"			1	5.00			
<b>SUBTOTAL:</b>							<b>506.25</b>	

DISTRICT 6  
PULASKI COUNTY

ROUTE	SECT.	LOG MILE (EXIT NO.) DIRECTION	SIGNS	LOCATION AND SIZE			TOTAL SIGNS	
				LEFT	RIGHT	FAR RIGHT	NO.	SQ. FT.
67	10	1A N.B.	STOP					
			YIELD					
			DO NOT ENTER	36"	36"		2	18.00
			ONE WAY	(2) 18"x 54"	(2) 18"x 54"		4	27.00
			WRONG WAY	30"x 42"	30"x 42"		2	17.50
KEEP RIGHT								
67	10	1B N.B.	STOP					
			YIELD					
			DO NOT ENTER	36"	36"	36"	2/1	24.25
			ONE WAY	(2) 18"x 54"	(2) 18"x 54"		4	27.00
			WRONG WAY	30"x 42"	30"x 42"		2	17.50
KEEP RIGHT								
67	10	3 N.B.	STOP					
			YIELD					
			DO NOT ENTER	36"	36"		2	18.00
			ONE WAY	(2) 18"x 54"	(2) 18"x 54"		4	27.00
			WRONG WAY	30"x 42"	30"x 42"		2	17.50
KEEP RIGHT								
67	10	8 N.B.	STOP	36"	36"		2	18.00
			YIELD			48"	1	7.00
			DO NOT ENTER	30"	30"	30"	3	18.75
			ONE WAY	(2) 12"x 36"	(2) 12"x 36"		4	12.00
			WRONG WAY	30"x 42"	30"x 42"		2	17.50
KEEP RIGHT								
67	23	9 N.B. (SLIP RAMP)	STOP					
			YIELD	* 48"	* 48"		2	14.00
			DO NOT ENTER	48"	48"		2	32.00
			ONE WAY					
			WRONG WAY	30"x 42"	30"x 42"		2	17.50
KEEP RIGHT								
67	10	9 S.B.	STOP	36"	36"		2	18.00
			YIELD					
			DO NOT ENTER	30"	30"		2	12.50
			ONE WAY	(2) 12"x 36"	(2) 12"x 36"		4	12.00
			WRONG WAY	30"x 42"	30"x 42"		2	17.50
KEEP RIGHT								
<b>SUBTOTAL:</b>							<b>390.50</b>	

HWY. 67 EXITS 2, 3 (S.B.), 4 (N.B.), AND 5 ARE ALL SLIP RAMPS ONTO A ONE-WAY FRONTAGE ROAD AND ARE NOT SUBJECT TO THE REQUIREMENTS OF SECTION 2B.41.

DISTRICT 6  
PULASKI COUNTY

ROUTE	SECT.	LOG MILE (EXIT NO.) DIRECTION	SIGNS	LOCATION AND SIZE			TOTAL SIGNS	
				LEFT	RIGHT	FAR RIGHT	NO.	SQ. FT.
67	10	10A N.B.	STOP	36"	36"		2	18.00
			YIELD					
			DO NOT ENTER	30"	30"		2	12.50
			ONE WAY	(2) 12"x 36"	(2) 12"x 36"		4	12.00
			WRONG WAY	30"x 42"	30"x 42"		2	17.50
KEEP RIGHT								
67	10	10A S.B.	STOP	36"	36"		2	18.00
			YIELD					
			DO NOT ENTER	30"	30"		2	12.50
			ONE WAY	(2) 12"x 36"	(2) 12"x 36"		4	12.00
			WRONG WAY	30"x 42"	30"x 42"		2	17.50
KEEP RIGHT								
67	10	10B N.B.	STOP	36"	36"		2	18.00
			YIELD					
			DO NOT ENTER	30"	30"		2	12.50
			ONE WAY	(2) 12"x 36"	(2) 12"x 36"		4	12.00
			WRONG WAY	30"x 42"	30"x 42"		2	17.50
KEEP RIGHT								
67	10	10B S.B.	STOP	36"	36"		2	18.00
			YIELD					
			DO NOT ENTER	30"	30"		2	12.50
			ONE WAY	(2) 12"x 36"	(2) 12"x 36"		4	12.00
			WRONG WAY	30"x 42"	30"x 42"		2	17.50
KEEP RIGHT								
67	10	11 N.B.	STOP	36"	36"		2	18.00
			YIELD					
			DO NOT ENTER	30"	30"		2	12.50
			ONE WAY	(2) 12"x 36"	(2) 12"x 36"		4	12.00
			WRONG WAY	30"x 42"	30"x 42"		2	17.50
KEEP RIGHT								
<b>SUBTOTAL:</b>							<b>300.00</b>	

NOTE: RED VERTICAL STRIPS SHALL BE PLACED ON ALL WRONG-WAY & DO NOT ENTER SIGN POSTS.

DATE REVISED	DATE FILED	DATE REVISED	DATE FILED	FED. RD. DIST. NO.	STATE	FED. AID PROJ. NO.	SHEET NO.	TOTAL SHEETS
				6	ARK.			
						JOB NO. 012260	30	61

② QUANTITIES



DISTRICT 6  
PULASKI COUNTY

ROUTE	SECT.	LOG MILE (EXIT NO.)	DIRECTION	SIGNS	LOCATION AND SIZE			TOTAL SIGNS	
					LEFT	RIGHT	FAR RIGHT	NO.	SQ. FT.
430	21	1	N.B.	STOP					
				YIELD			48"	1	7.00
				DO NOT ENTER	36"	36"	30"	2/1	24.25
				ONE WAY	(2) 18"x 54"	(2) 18"x 54"		4	27.00
				WRONG WAY	30"x 42"	30"x 42"		2	17.50
				KEEP RIGHT					
430	21	1	S.B.	STOP					
				YIELD					
				DO NOT ENTER	36"	36"	30"	2/1	24.25
				ONE WAY	(2) 18"x 54"	(2) 18"x 54"		4	27.00
				WRONG WAY	30"x 42"	30"x 42"		2	17.50
				KEEP RIGHT					
430	21	4	N.B.	STOP			48"	1	7.00
				YIELD					
				DO NOT ENTER	36"	36"	30"	2/1	24.25
				ONE WAY	(2) 18"x 54"	(2) 18"x 54"		4	27.00
				WRONG WAY	30"x 42"	30"x 42"		2	17.50
				KEEP RIGHT					
430	21	4	S.B.	STOP					
				YIELD					
				DO NOT ENTER	36"	36"	30"	2/1	24.25
				ONE WAY	(2) 18"x 54"	(2) 18"x 54"		4	27.00
				WRONG WAY	30"x 42"	30"x 42"		2	17.50
				KEEP RIGHT					
430	21	5	N.B.	STOP					
				YIELD					
				DO NOT ENTER	48"	48"	48"	3	48.00
				ONE WAY	(2) 18"x 54"	(2) 18"x 54"		4	27.00
				WRONG WAY	30"x 42"	30"x 42"		2	17.50
				KEEP RIGHT					
430	21	5	S.B.	STOP			48"	3	48.00
				YIELD					
				DO NOT ENTER	48"	48"	48"	3	48.00
				ONE WAY	(2) 18"x 54"	(2) 18"x 54"		4	27.00
				WRONG WAY	30"x 42"	30"x 42"		2	17.50
				KEEP RIGHT					
<b>SUBTOTAL:</b>								<b>474.00</b>	

DISTRICT 6  
PULASKI COUNTY

ROUTE	SECT.	LOG MILE (EXIT NO.)	DIRECTION	SIGNS	LOCATION AND SIZE			TOTAL SIGNS	
					LEFT	RIGHT	FAR RIGHT	NO.	SQ. FT.
430	21	8	N.B.	STOP					
				YIELD			48"	1	7.00
				DO NOT ENTER	48"	48"	30"	2/1	38.25
				ONE WAY	(2) 18"x 54"	(2) 18"x 54"		4	27.00
				WRONG WAY	30"x 42"	30"x 42"		2	17.50
				KEEP RIGHT					
430	21	8	S.B.	STOP					
				YIELD					
				DO NOT ENTER	48"	48"		2	32.00
				ONE WAY	(2) 18"x 54"	(2) 18"x 54"		4	27.00
				WRONG WAY	30"x 42"	30"x 42"		2	17.50
				KEEP RIGHT					
430	21	9	N.B.	STOP			48"	1	7.00
				YIELD					
				DO NOT ENTER		48"		1	16.00
				ONE WAY		(2) 18"x 54"		2	13.50
				WRONG WAY	30"x 42"	30"x 42"		2	17.50
				KEEP RIGHT	24"x 30"			1	5.00
430	21	12	N.B.	STOP					
				YIELD			48"	1	7.00
				DO NOT ENTER	36"	36"	30"	2/1	24.25
				ONE WAY	(2) 18"x 54"	(2) 18"x 54"		4	27.00
				WRONG WAY	30"x 42"	30"x 42"		2	17.50
				KEEP RIGHT					
430	21	12	S.B.	STOP	48"	48"		2	32.00
				YIELD					
				DO NOT ENTER	36"	36"		2	18.00
				ONE WAY	(2) 18"x 54"	(2) 18"x 54"		4	27.00
				WRONG WAY	30"x 42"	30"x 42"		2	17.50
				KEEP RIGHT					
440	1	1	E.B.	STOP	48"	48"		2	32.00
				YIELD			48"	1	7.00
				DO NOT ENTER		36"	30"	1/1	15.25
				ONE WAY		(2) 18"x 54"		2	13.50
				WRONG WAY	30"x 42"	30"x 42"		2	17.50
				KEEP RIGHT	24"x 30"			1	5.00
<b>SUBTOTAL:</b>								<b>485.75</b>	

DISTRICT 6  
PULASKI COUNTY

ROUTE	SECT.	LOG MILE (EXIT NO.)	DIRECTION	SIGNS	LOCATION AND SIZE			TOTAL SIGNS	
					LEFT	RIGHT	FAR RIGHT	NO.	SQ. FT.
440	1	1	W.B.	STOP	48"	48"		2	32.00
				YIELD			48"	1	7.00
				DO NOT ENTER		36"	30"	1/1	15.25
				ONE WAY		(2) 18"x 54"		2	13.50
				WRONG WAY	30"x 42"	30"x 42"		2	17.50
				KEEP RIGHT	24"x 30"			1	5.00
440	1	3	E.B.	STOP	48"	48"		2	32.00
				YIELD			48"	1	7.00
				DO NOT ENTER	36"	36"	30"	2/1	24.25
				ONE WAY	(2) 18"x 54"	(2) 18"x 54"		4	27.00
				WRONG WAY	30"x 42"	30"x 42"		2	17.50
				KEEP RIGHT					
440	1	3	W.B.	STOP	48"	48"		2	32.00
				YIELD					
				DO NOT ENTER	36"	36"	30"	2/1	24.25
				ONE WAY	(2) 18"x 54"	(2) 18"x 54"		4	27.00
				WRONG WAY	30"x 42"	30"x 42"		2	17.50
				KEEP RIGHT					
440	1	4	E.B.	STOP	36"	36"		2	18.00
				YIELD			48"	1	7.00
				DO NOT ENTER	30"	30"	30"	3	18.75
				ONE WAY	(2) 12"x 36"	(2) 12"x 36"		4	12.00
				WRONG WAY	30"x 42"	30"x 42"		2	17.50
				KEEP RIGHT					
440	1	4	W.B.	STOP	36"	36"		2	18.00
				YIELD			48"	1	7.00
				DO NOT ENTER	30"	30"	30"	3	18.75
				ONE WAY	(2) 12"x 36"	(2) 12"x 36"		4	12.00
				WRONG WAY	30"x 42"	30"x 42"		2	17.50
				KEEP RIGHT					
440	1	5	E.B.	STOP	36"	36"		2	18.00
				YIELD			48"	1	7.00
				DO NOT ENTER	30"	30"	30"	3	18.75
				ONE WAY	(2) 12"x 36"	(2) 12"x 36"		4	12.00
				WRONG WAY	30"x 42"	30"x 42"		2	17.50
				KEEP RIGHT					
<b>SUBTOTAL:</b>								<b>518.50</b>	

\* ON INTERSECTING ROADWAY. ON ALL SLIP RAMPS TO TWO-WAY FRONTAGE ROADS, (2) 48" W6-3 SIGNS ARE REQUIRED ON THE FRONTAGE ROAD JUST BEYOND THE RAMP. I-30 EXITS 128, 129, 130, 131, 134, 139, 140, 141, AND 142 ARE ALL SLIP RAMPS ONTO A ONE-WAY FRONTAGE ROAD AND ARE NOT SUBJECT TO THE REQUIREMENTS OF SECTION 2B.41.

NOTE: RED VERTICAL STRIPS SHALL BE PLACED ON ALL WRONG-WAY & DO NOT ENTER SIGN POSTS.

DATE REVISED	DATE FILMED	DATE REVISED	DATE FILMED	FED. RD. DIST. NO.	STATE	FED. AID PROJ. NO.	SHEET NO.	TOTAL SHEETS
				6	ARK.			
JOB NO.						012260	31	61

② QUANTITIES

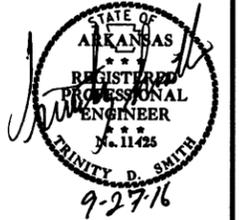

DISTRICT 6  
PULASKI COUNTY

ROUTE	SECT.	LOG MILE (EXIT NO.) DIRECTION	SIGNS	LOCATION AND SIZE			TOTAL SIGNS	
				LEFT	RIGHT	FAR RIGHT	NO.	SQ. FT.
440	1	5 W.B.	STOP	36"	36"		2	18.00
			YIELD			48"	1	7.00
			DO NOT ENTER	30"	30"	30"	3	18.75
			ONE WAY	(2) 12"x 36"	(2) 12"x 36"		4	12.00
			WRONG WAY	30"x 42"	30"x 42"		2	17.50
			KEEP RIGHT					
440	1	7 E.B.	STOP	48"	48"		2	32.00
			YIELD			48"	1	7.00
			DO NOT ENTER		36"	30"	1/1	15.25
			ONE WAY		(2) 18"x 54"		2	13.50
			WRONG WAY	30"x 42"	30"x 42"		2	17.50
			KEEP RIGHT	24"x 30"			1	5.00
440	1	7 W.B.	STOP	48"	48"		2	32.00
			YIELD			48"	1	7.00
			DO NOT ENTER		36"	30"	1/1	15.25
			ONE WAY		(2) 18"x 54"		2	13.50
			WRONG WAY	30"x 42"	30"x 42"		2	17.50
			KEEP RIGHT	24"x 30"			1	5.00
440	1	8 E.B.	STOP	36"	36"		2	18.00
			YIELD					
			DO NOT ENTER	30"	30"		2	12.50
			ONE WAY	(2) 12"x 36"	(2) 12"x 36"		4	12.00
			WRONG WAY	30"x 42"	30"x 42"		2	17.50
			KEEP RIGHT					
440	1	8 W.B.	STOP	36"	36"		2	18.00
			YIELD					
			DO NOT ENTER	30"	30"		2	12.50
			ONE WAY	(2) 12"x 36"	(2) 12"x 36"		4	12.00
			WRONG WAY	30"x 42"	30"x 42"		2	17.50
			KEEP RIGHT					
440	1	10 E.B.	STOP	48"	48"		2	32.00
			YIELD			48"	1	7.00
			DO NOT ENTER		36"	30"	1/1	15.25
			ONE WAY		(2) 18"x 54"		2	13.50
			WRONG WAY	30"x 42"	30"x 42"		2	17.50
			KEEP RIGHT	24"x 30"			1	5.00
<b>SUBTOTAL:</b>							<b>464.00</b>	

DISTRICT 6  
PULASKI COUNTY

ROUTE	SECT.	LOG MILE (EXIT NO.) DIRECTION	SIGNS	LOCATION AND SIZE			TOTAL SIGNS	
				LEFT	RIGHT	FAR RIGHT	NO.	SQ. FT.
440	1	10 W.B.	STOP	48"	48"		2	32.00
			YIELD			48"	1	7.00
			DO NOT ENTER		36"	30"	1/1	15.25
			ONE WAY		(2) 18"x 54"		2	13.50
			WRONG WAY	30"x 42"	30"x 42"		2	17.50
			KEEP RIGHT	24"x 30"			1	5.00
440	2	12 E.B.	STOP	48"	48"		2	32.00
			YIELD			48"	1	7.00
			DO NOT ENTER	36"	36"	30"	2/1	24.25
			ONE WAY	(2) 18"x 54"	(2) 18"x 54"		4	27.00
			WRONG WAY	30"x 42"	30"x 42"		2	17.50
			KEEP RIGHT					
440	2	12 W.B.	STOP	48"	48"		2	32.00
			YIELD			48"	1	7.00
			DO NOT ENTER	36"	36"	30"	2/1	24.25
			ONE WAY	(2) 18"x 54"	(2) 18"x 54"		4	27.00
			WRONG WAY	30"x 42"	30"x 42"		2	17.50
			KEEP RIGHT					
530	3	15 N.B.	STOP	36"	36"		2	18.00
			YIELD			48"	1	7.00
			DO NOT ENTER	30"	30"	30"	3	18.75
			ONE WAY	(2) 12"x 36"	(2) 12"x 36"		4	12.00
			WRONG WAY	30"x 42"	30"x 42"		2	17.50
			KEEP RIGHT					
530	3	15 S.B.	STOP	36"	36"		2	18.00
			YIELD			48"	1	7.00
			DO NOT ENTER	30"	30"	30"	3	18.75
			ONE WAY	(2) 12"x 36"	(2) 12"x 36"		4	12.00
			WRONG WAY	30"x 42"	30"x 42"		2	17.50
			KEEP RIGHT					
530	1	9 N.B.	STOP	36"	36"		2	18.00
			YIELD			48"	1	7.00
			DO NOT ENTER	30"	30"	30"	3	18.75
			ONE WAY	(2) 12"x 36"	(2) 12"x 36"		4	12.00
			WRONG WAY	30"x 42"	30"x 42"		2	17.50
			KEEP RIGHT					
<b>SUBTOTAL:</b>							<b>525.50</b>	

DISTRICT 6  
PULASKI COUNTY

ROUTE	SECT.	LOG MILE (EXIT NO.) DIRECTION	SIGNS	LOCATION AND SIZE			TOTAL SIGNS	
				LEFT	RIGHT	FAR RIGHT	NO.	SQ. FT.
530	1	9 S.B.	STOP	36"	36"		2	18.00
			YIELD			48"	1	7.00
			DO NOT ENTER	30"	30"	30"	3	18.75
			ONE WAY	(2) 12"x 36"	(2) 12"x 36"		4	12.00
			WRONG WAY	30"x 42"	30"x 42"		2	17.50
			KEEP RIGHT					
530	1	7 N.B.	STOP	36"	36"		2	18.00
			YIELD			48"	1	7.00
			DO NOT ENTER	30"	30"	30"	3	18.75
			ONE WAY	(2) 12"x 36"	(2) 12"x 36"		4	12.00
			WRONG WAY	30"x 42"	30"x 42"		2	17.50
			KEEP RIGHT					
530	1	7 S.B.	STOP	36"	36"		2	18.00
			YIELD			48"	1	7.00
			DO NOT ENTER	30"	30"	30"	3	18.75
			ONE WAY	(2) 12"x 36"	(2) 12"x 36"		4	12.00
			WRONG WAY	30"x 42"	30"x 42"		2	17.50
			KEEP RIGHT					
530	1	3 N.B.	STOP				2	14.00
			YIELD	* 48"	* 48"		2	14.00
			DO NOT ENTER	48"	48"		2	32.00
			ONE WAY					
			WRONG WAY	30"x 42"	30"x 42"		2	17.50
			KEEP RIGHT					
530	1	3 S.B.	STOP	36"	36"		2	18.00
			YIELD			48"	1	7.00
			DO NOT ENTER	30"	30"	30"	3	18.75
			ONE WAY	(2) 12"x 36"	(2) 12"x 36"		4	12.00
			WRONG WAY	30"x 42"	30"x 42"		2	17.50
			KEEP RIGHT					
630	21	1A W.B.	STOP				1	7.00
			YIELD	48"			1	7.00
			DO NOT ENTER		36"	30"	1/1	15.25
			ONE WAY		(2) 18"x 54"	(2) 18"x 54"	4	27.00
			WRONG WAY		30"x 42"	30"x 42"	2	17.50
			KEEP RIGHT					
<b>SUBTOTAL:</b>							<b>423.25</b>	

\* ON INTERSECTING ROADWAY. ON ALL SLIP RAMPS TO TWO-WAY FRONTAGE ROADS, (2) 48" W6-3 SIGNS ARE REQUIRED ON THE FRONTAGE ROAD JUST BEYOND THE RAMP.

NOTE: RED VERTICAL STRIPS SHALL BE PLACED ON ALL WRONG-WAY & DO NOT ENTER SIGN POSTS.

② QUANTITIES



DISTRICT 6  
PULASKI COUNTY

ROUTE	SECT.	LOG MILE (EXIT NO.) DIRECTION	SIGNS	LOCATION AND SIZE			TOTAL SIGNS	
				LEFT	RIGHT	FAR RIGHT	NO.	SQ. FT.
630	21	2A W.B.	STOP			48"	1	7.00
			YIELD					
			DO NOT ENTER		36"		1	9.00
			ONE WAY		(2) 18"x 54"		2	13.50
			WRONG WAY	30"x 42"	30"x 42"		2	17.50
			KEEP RIGHT	24"x 30"			1	5.00
630	21	2A E.B.	STOP			48"	1	7.00
			YIELD					
			DO NOT ENTER		36"		1	9.00
			ONE WAY		(2) 18"x 54"		2	13.50
			WRONG WAY	30"x 42"	30"x 42"		2	17.50
			KEEP RIGHT	24"x 30"			1	5.00
630	21	2B W.B.	STOP			48"	1	7.00
			YIELD					
			DO NOT ENTER	36"	36"	30"	2/1	24.25
			ONE WAY	(2) 18"x 54"	(2) 18"x 54"		4	27.00
			WRONG WAY	30"x 42"	30"x 42"		2	17.50
			KEEP RIGHT					
630	21	3A W.B.	STOP	48"	48"		2	32.00
			YIELD			48"	1	7.00
			DO NOT ENTER	36"	36"	30"	2/1	24.25
			ONE WAY	(2) 18"x 54"	(2) 18"x 54"		4	27.00
			WRONG WAY	30"x 42"	30"x 42"		2	17.50
			KEEP RIGHT					
630	21	3A E.B.	STOP	48"	48"		2	32.00
			YIELD			48"	1	7.00
			DO NOT ENTER	36"	36"	30"	2/1	24.25
			ONE WAY	(2) 18"x 54"	(2) 18"x 54"		4	27.00
			WRONG WAY	30"x 42"	30"x 42"		2	17.50
			KEEP RIGHT					
630	21	3B W.B.	STOP			48"	1	7.00
			YIELD					
			DO NOT ENTER	36"	36"	30"	2/1	24.25
			ONE WAY	(2) 18"x 54"	(2) 18"x 54"		4	27.00
			WRONG WAY	30"x 42"	30"x 42"		2	17.50
			KEEP RIGHT					
<b>SUBTOTAL:</b>							<b>471.00</b>	

\* ON INTERSECTING ROADWAY. ON ALL SLIP RAMPS TO TWO-WAY FRONTAGE ROADS, (2) 48" W6-3 SIGNS ARE REQUIRED ON THE FRONTAGE ROAD JUST BEYOND THE RAMP. I-630 EXITS 1B (W.B.), 1A (E.B.), 1B (E.B.), AND 2B (E.B.) ARE ALL SLIP RAMPS ONTO A ONE-WAY FRONTAGE ROAD AND ARE NOT SUBJECT TO THE REQUIREMENTS OF SECTION 2B.41.

DISTRICT 6  
PULASKI COUNTY

ROUTE	SECT.	LOG MILE (EXIT NO.) DIRECTION	SIGNS	LOCATION AND SIZE			TOTAL SIGNS	
				LEFT	RIGHT	FAR RIGHT	NO.	SQ. FT.
630	21	3B E.B.	STOP					
			YIELD					
			DO NOT ENTER	36"	36"		2	18.00
			ONE WAY	(2) 18"x 54"	(2) 18"x 54"		4	27.00
			WRONG WAY	30"x 42"	30"x 42"		2	17.50
			KEEP RIGHT					
630	21	4 W.B.	STOP			48"	1	7.00
			YIELD					
			DO NOT ENTER	36"	36"	30"	2/1	24.25
			ONE WAY	(2) 18"x 54"	(2) 18"x 54"		4	27.00
			WRONG WAY	30"x 42"	30"x 42"		2	17.50
			KEEP RIGHT					
630	21	4 E.B.	STOP			48"	1	7.00
			YIELD					
			DO NOT ENTER	36"	36"	30"	2/1	24.25
			ONE WAY	(2) 18"x 54"	(2) 18"x 54"		4	27.00
			WRONG WAY	30"x 42"	30"x 42"		2	17.50
			KEEP RIGHT					
<b>SUBTOTAL:</b>							<b>214.00</b>	

DISTRICT 6  
PULASKI COUNTY

ROUTE	SECT.	LOG MILE (EXIT NO.) DIRECTION	SIGNS	LOCATION AND SIZE			TOTAL SIGNS		
				LEFT	RIGHT	FAR RIGHT	NO.	SQ. FT.	
630	21	7	STOP		36"	36"		2	18.00
			YIELD						
			DO NOT ENTER	36"	36"		2	18.00	
			ONE WAY	(2) 18"x 54"	(2) 18"x 54"		4	27.00	
			WRONG WAY	30"x 42"	30"x 42"		2	17.50	
			KEEP RIGHT						
<b>SUBTOTAL:</b>							<b>80.50</b>		
<b>TOTAL PULASKI COUNTY:</b>							<b>6109.25</b>		

NOTE: RED VERTICAL STRIPS SHALL BE PLACED ON ALL WRONG-WAY & DO NOT ENTER SIGN POSTS.

r012260.dgn Quantities

9/26/16

DATE REVISED	DATE FILMED	DATE REVISED	DATE FILMED	FED. RD. DIST. NO.	STATE	FED. AID PROJ. NO.	SHEET NO.	TOTAL SHEETS
12/13/16				6	ARK.			
				JOB NO.	012260		33	61

② QUANTITIES



DISTRICT 6  
LONOKE COUNTY

ROUTE	SECT.	LOG MILE (EXIT NO.) DIRECTION	SIGNS	LOCATION AND SIZE			TOTAL SIGNS	
				LEFT	RIGHT	FAR RIGHT	NO.	SQ. FT.
40	41	165 E.B.	STOP	36"	36"		2	18.00
			YIELD			48"	1	7.00
			DO NOT ENTER	30"	30"	30"	3	18.75
			ONE WAY	(2) 12"x 36"	(2) 12"x 36"		4	12.00
			WRONG WAY	30"x 42"	30"x 42"		2	17.50
40	41	165 W.B.	STOP	36"	36"		2	18.00
			YIELD			48"	1	7.00
			DO NOT ENTER	30"	30"	30"	3	18.75
			ONE WAY	(2) 12"x 36"	(2) 12"x 36"		4	12.00
			WRONG WAY	30"x 42"	30"x 42"		2	17.50
40	41	169 E.B.	STOP	36"	36"		2	18.00
			YIELD			48"	1	7.00
			DO NOT ENTER	30"	30"	30"	3	18.75
			ONE WAY	(2) 12"x 36"	(2) 12"x 36"		4	12.00
			WRONG WAY	30"x 42"	30"x 42"		2	17.50
40	41	169 W.B.	STOP	36"	36"		2	18.00
			YIELD			48"	1	7.00
			DO NOT ENTER	30"	30"	30"	3	18.75
			ONE WAY	(2) 12"x 36"	(2) 12"x 36"		4	12.00
			WRONG WAY	30"x 42"	30"x 42"		2	17.50
40	41	175 E.B.	STOP			48"	1	7.00
			YIELD			30"	3	18.75
			DO NOT ENTER	30"	30"	30"	3	18.75
			ONE WAY	(2) 12"x 36"	(2) 12"x 36"		4	12.00
			WRONG WAY	30"x 42"	30"x 42"		2	17.50
40	41	175 W.B.	STOP	36"	36"		2	18.00
			YIELD			48"	1	7.00
			DO NOT ENTER	30"	30"	30"	3	18.75
			ONE WAY	(2) 12"x 36"	(2) 12"x 36"		4	12.00
			WRONG WAY	30"x 42"	30"x 42"		2	17.50
SUBTOTAL:								421.50

DISTRICT 6  
LONOKE COUNTY

ROUTE	SECT.	LOG MILE (EXIT NO.) DIRECTION	SIGNS	LOCATION AND SIZE			TOTAL SIGNS	
				LEFT	RIGHT	FAR RIGHT	NO.	SQ. FT.
40	41	183 E.B.	STOP	48"	48"		2	32.00
			YIELD			48"	1	7.00
			DO NOT ENTER		36"	30"	1/1	15.25
			ONE WAY		(2) 18"x 54"		2	13.50
			WRONG WAY	30"x 42"	30"x 42"		2	17.50
			KEEP RIGHT	24"x 30"			1	5.00
40	41	183 W.B.	STOP	36"	36"		2	18.00
			YIELD			48"	1	7.00
			DO NOT ENTER	30"	30"	30"	3	18.75
			ONE WAY	(2) 12"x 36"	(2) 12"x 36"		4	12.00
			WRONG WAY	30"x 42"	30"x 42"		2	17.50
			KEEP RIGHT				1	5.00
40	41	173 E.B.	STOP	36"	36"		2	18.00
			YIELD			48"	1	7.00
			DO NOT ENTER	36"	36"	36"	3	18.75
			ONE WAY					
			WRONG WAY	30"x 42"	30"x 42"		2	17.50
			KEEP RIGHT					
40	41	173 W.B.	STOP	48"	48"		2	32.00
			YIELD			48"	1	7.00
			DO NOT ENTER		36"	36"	2	18.00
			ONE WAY					
			WRONG WAY	30"x 42"	30"x 42"		2	17.50
			KEEP RIGHT	24"x 30"			1	5.00
67	11	16B N.B.	STOP					
			YIELD					
			DO NOT ENTER					
			ONE WAY					
			WRONG WAY	30"x 42"	30"x 42"		2	17.50
			KEEP RIGHT					
SUBTOTAL:								321.75

DISTRICT 6  
LONOKE COUNTY

ROUTE	SECT.	LOG MILE (EXIT NO.) DIRECTION	SIGNS	LOCATION AND SIZE			TOTAL SIGNS		
				LEFT	RIGHT	FAR RIGHT	NO.	SQ. FT.	
67	11	16 S.B.	STOP	36"	36"		2	18.00	
			YIELD			48"	1	7.00	
			DO NOT ENTER	30"	30"	30"	3	18.75	
			ONE WAY	(2) 12"x 36"	(2) 12"x 36"		4	12.00	
			WRONG WAY	30"x 42"	30"x 42"		2	17.50	
			KEEP RIGHT						
67	11	19 N.B.	STOP			(2) 48"	2	32.00	
			YIELD			36"	(2) 30"	1/2	15.25
			DO NOT ENTER						
			ONE WAY		(2) 18"x 54"		2	13.50	
			WRONG WAY	30"x 42"	30"x 42"		2	17.50	
			KEEP RIGHT	24"x 30"			1	5.00	
67	11	19 S.B.	STOP			(2) 48"	2	14.00	
			YIELD			36"	(2) 30"	2/2	30.50
			DO NOT ENTER	36"	36"				
			ONE WAY	(2) 12"x 36"	(2) 12"x 36"		4	12.00	
			WRONG WAY	30"x 42"	30"x 42"		2	17.50	
			KEEP RIGHT						
67	11	22 N.B.	STOP	36"	36"		2	18.00	
			YIELD			48"	1	7.00	
			DO NOT ENTER	30"	30"	30"	3	18.75	
			ONE WAY	(2) 12"x 36"	(2) 12"x 36"		4	12.00	
			WRONG WAY	30"x 42"	30"x 42"		2	17.50	
			KEEP RIGHT						
67	11	22 S.B.	STOP	36"	36"		2	18.00	
			YIELD			48"	1	7.00	
			DO NOT ENTER	30"	30"	30"	3	18.75	
			ONE WAY	(2) 12"x 36"	(2) 12"x 36"		4	12.00	
			WRONG WAY	30"x 42"	30"x 42"		2	17.50	
			KEEP RIGHT						
67	11	25 N.B.	STOP	36"	36"		2	18.00	
			YIELD			48"	1	7.00	
			DO NOT ENTER	30"	30"	30"	3	18.75	
			ONE WAY	(2) 12"x 36"	(2) 12"x 36"		4	12.00	
			WRONG WAY	30"x 42"	30"x 42"		2	17.50	
			KEEP RIGHT						
67	11	25 S.B.	STOP	36"	36"		2	18.00	
			YIELD			48"	1	7.00	
			DO NOT ENTER	30"	30"	30"	3	18.75	
			ONE WAY	(2) 12"x 36"	(2) 12"x 36"		4	12.00	
			WRONG WAY	30"x 42"	30"x 42"		2	17.50	
			KEEP RIGHT						
SUBTOTAL:								523.50	
TOTAL LONOKE COUNTY:								1329.25	

NOTE: RED VERTICAL STRIPS SHALL BE PLACED ON ALL WRONG-WAY & DO NOT ENTER SIGN POSTS.

DATE REVISED	DATE FILMED	DATE REVISED	DATE FILMED	FED. RD. DIST. NO.	STATE	FED. AID PROJ. NO.	SHEET NO.	TOTAL SHEETS
12/13/16				6	ARK.			
						JOB NO. 012260	34	61

② QUANTITIES



DISTRICT 6  
PRAIRIE COUNTY

ROUTE	SECT.	LOG MILE (EXIT NO.) DIRECTION	SIGNS	LOCATION AND SIZE			TOTAL SIGNS	
				LEFT	RIGHT	FAR RIGHT	NO.	SQ. FT.
40	42	193 E.B.	STOP	36"	36"		2	18.00
			YIELD					
			DO NOT ENTER	30"	30"		2	12.50
			ONE WAY	(2) 12"x 36"	(2) 12"x 36"		4	12.00
			WRONG WAY	30"x 42"	30"x 42"		2	17.50
40	42	193 W.B.	STOP	36"	36"		2	18.00
			YIELD					
			DO NOT ENTER	30"	30"		2	12.50
			ONE WAY	(2) 12"x 36"	(2) 12"x 36"		4	12.00
			WRONG WAY	30"x 42"	30"x 42"		2	17.50
40	42	202 E.B.	STOP	36"	36"		2	18.00
			YIELD					
			DO NOT ENTER	30"	30"		2	12.50
			ONE WAY	(2) 12"x 36"	(2) 12"x 36"		4	12.00
			WRONG WAY	30"x 42"	30"x 42"		2	17.50
40	42	202 W.B.	STOP	36"	36"		2	18.00
			YIELD					
			DO NOT ENTER	30"	30"		2	12.50
			ONE WAY	(2) 12"x 36"	(2) 12"x 36"		4	12.00
			WRONG WAY	30"x 42"	30"x 42"		2	17.50
TOTAL PRAIRIE COUNTY:							240.00	

DISTRICT 6  
GARLAND COUNTY

ROUTE	SECT.	LOG MILE (EXIT NO.) DIRECTION	SIGNS	LOCATION AND SIZE			TOTAL SIGNS	
				LEFT	RIGHT	FAR RIGHT	NO.	SQ. FT.
270	5	1 W.B. (270 @ WESTON RD. INT.)	STOP	48"	48"		2	32.00
			YIELD					
			DO NOT ENTER	36"	36"		2	18.00
			ONE WAY	(2) 18"x 54"	(2) 18"x 54"		4	27.00
			WRONG WAY	30"x 42"	30"x 42"		2	17.50
270	5	1 W.B.	STOP	48"	48"		2	14.00
			YIELD	48"	48"		2	18.00
			DO NOT ENTER	36"	36"		4	27.00
			ONE WAY	(2) 18"x 54"	(2) 18"x 54"		2	17.50
			WRONG WAY	30"x 42"	30"x 42"		2	17.50
270	5	2 E.B.	STOP	48"	48"		2	32.00
			YIELD			48"	1	7.00
			DO NOT ENTER	36"	36"	30"	2/1	24.25
			ONE WAY	(2) 18"x 54"	(2) 18"x 54"		4	27.00
			WRONG WAY	30"x 42"	30"x 42"		2	17.50
270	5	2 W.B.	STOP			48"	1	7.00
			YIELD			48"	2/1	24.25
			DO NOT ENTER	36"	36"	30"	4	27.00
			ONE WAY	(2) 18"x 54"	(2) 18"x 54"		2	17.50
			WRONG WAY	30"x 42"	30"x 42"		2	17.50
270	5	3 E.B.	STOP	36"	36"		2	18.00
			YIELD			48"	1	7.00
			DO NOT ENTER	30"	30"	30"	3	18.75
			ONE WAY	(2) 12"x 36"	(2) 12"x 36"		4	12.00
			WRONG WAY	30"x 42"	30"x 42"		2	17.50
270	5	3 W.B.	STOP	36"	36"		2	18.00
			YIELD			48"	1	7.00
			DO NOT ENTER	30"	30"	30"	3	18.75
			ONE WAY	(2) 12"x 36"	(2) 12"x 36"		4	12.00
			WRONG WAY	30"x 42"	30"x 42"		2	17.50
SUBTOTAL:							501.00	

NOTE: RED VERTICAL STRIPS SHALL BE PLACED ON ALL WRONG-WAY & DO NOT ENTER SIGN POSTS.

DATE REVISED	DATE FILMED	DATE REVISED	DATE FILMED	FED. RD. DIST. NO.	STATE	FED. AID PROJ. NO.	SHEET NO.	TOTAL SHEETS
12/13/16				6	ARK.			
				JOB NO.		012260	35	61

② QUANTITIES



DISTRICT 6  
GARLAND COUNTY

ROUTE	SECT.	LOG MILE (EXIT NO.) DIRECTION	SIGNS	LOCATION AND SIZE			TOTAL SIGNS	
				LEFT	RIGHT	FAR RIGHT	NO.	SQ. FT.
270	5	4 E.B.	STOP			48"	1	7.00
			YIELD					
			DO NOT ENTER	36"	36"	30"	2/1	24.25
			ONE WAY	(2) 18"x 54"	(2) 18"x 54"		4	27.00
			WRONG WAY	30"x 42"	30"x 42"		2	17.50
			KEEP RIGHT					
270	5	4 W.B.	STOP			48"	1	7.00
			YIELD					
			DO NOT ENTER	36"	36"	30"	2/1	24.25
			ONE WAY	(2) 18"x 54"	(2) 18"x 54"		4	27.00
			WRONG WAY	30"x 42"	30"x 42"		2	17.50
			KEEP RIGHT					
270	5	5A E.B.	STOP			48"	2	14.00
			YIELD	48"	48"			
			DO NOT ENTER	36"	36"		2	18.00
			ONE WAY	(2) 18"x 54"	(2) 18"x 54"		4	27.00
			WRONG WAY	30"x 42"	30"x 42"		2	17.50
			KEEP RIGHT					
270	6	5B E.B.	STOP	48"	48"		2	32.00
			YIELD					
			DO NOT ENTER		36"		1	9.00
			ONE WAY		(2) 18"x 54"		2	13.50
			WRONG WAY	30"x 42"	30"x 42"		2	17.50
			KEEP RIGHT	24"x 30"			1	5.00
270	5	5A W.B.	STOP	48"	48"		2	32.00
			YIELD					
			DO NOT ENTER	36"	36"		2	18.00
			ONE WAY	(2) 18"x 54"	(2) 18"x 54"		4	27.00
			WRONG WAY	30"x 42"	30"x 42"		2	17.50
			KEEP RIGHT	24"x 30"			1	5.00
270	6	5B W.B.	STOP			48"	2	14.00
			YIELD	48"	48"			
			DO NOT ENTER	36"	36"		2	18.00
			ONE WAY	(2) 18"x 54"	(2) 18"x 54"		4	27.00
			WRONG WAY	30"x 42"	30"x 42"		2	17.50
			KEEP RIGHT					
							481.00	

DISTRICT 6  
GARLAND COUNTY

ROUTE	SECT.	LOG MILE (EXIT NO.) DIRECTION	SIGNS	LOCATION AND SIZE			TOTAL SIGNS	
				LEFT	RIGHT	FAR RIGHT	NO.	SQ. FT.
270	6	7 E.B.	STOP			48"	1	7.00
			YIELD					
			DO NOT ENTER	36"	36"	30"	2/1	24.25
			ONE WAY	(2) 18"x 54"	(2) 18"x 54"		4	27.00
			WRONG WAY	30"x 42"	30"x 42"		2	17.50
			KEEP RIGHT					
270	6	7 W.B.	STOP			48"	1	7.00
			YIELD					
			DO NOT ENTER	36"	36"	30"	2/1	24.25
			ONE WAY	(2) 18"x 54"	(2) 18"x 54"		4	27.00
			WRONG WAY	30"x 42"	30"x 42"		2	17.50
			KEEP RIGHT					
270	6	9 E.B.	STOP	48"	48"		2	32.00
			YIELD			48"	1	7.00
			DO NOT ENTER	36"	36"	30"	2/1	24.25
			ONE WAY	(2) 18"x 54"	(2) 18"x 54"		4	27.00
			WRONG WAY	30"x 42"	30"x 42"		2	17.50
			KEEP RIGHT					
270	6	9 W.B.	STOP			48"	1	7.00
			YIELD					
			DO NOT ENTER	36"	36"	30"	2/1	24.25
			ONE WAY	(2) 18"x 54"	(2) 18"x 54"		4	27.00
			WRONG WAY	30"x 42"	30"x 42"		2	17.50
			KEEP RIGHT					
270	6	E.B. (U.S. 70E INT.)	STOP	48"	48"		2	32.00
			YIELD					
			DO NOT ENTER	36"	36"		2	18.00
			ONE WAY	(2) 18"x 54"	(2) 18"x 54"		4	27.00
			WRONG WAY	30"x 42"	30"x 42"		2	17.50
			KEEP RIGHT					
SUBTOTAL:							429.50	
TOTAL GARLAND COUNTY:							1411.50	
TOTAL DISTRICT 6:							10872.00	

NOTE: RED VERTICAL STRIPS SHALL BE PLACED ON ALL WRONG-WAY & DO NOT ENTER SIGN POSTS.

DATE REVISED	DATE FILMED	DATE REVISED	DATE FILMED	FED. RD. DIST. NO.	STATE	FED. AID PROJ. NO.	SHEET NO.	TOTAL SHEETS
12/13/16				6	ARK.			
				JOB NO. 012260		36	61	

② QUANTITIES



STOP LINES, WRONG-WAY ARROWS, AND RAMP DELINEATORS (BOX 1 OF 4)

DISTRICT	COUNTY	ROUTE	MAIN LANE SECTION	RAMP SECTION	EXIT NUMBER	CROSS ROAD	STOP LINES	YIELD LINES	THERMO. WRONG-WAY PAVEMENT ARROWS	DELINEATOR (TYPE 2) YELLOW	DELINEATOR (TYPE 2) WHITE	TYPE OF RAMP
							LIN. FT.	LIN. FT.	EACH	EACH	EACH	
6	GARLAND	70	9B	111	2	7S			1	6	11	TYPICAL DIAMOND
6	GARLAND	70	6	169	9	270/270B	21	17	1	14	12	TYPICAL DIAMOND
6	GARLAND	70	9B	24B	2	E GRAND AVE.	21		1	15	22	SLIP
6	GARLAND	70	9B	26B	3	E GRAND AVE.			1	11	13	SLIP
6	GARLAND	70	9B	28B	3	E GRAND AVE.			1	3	10	SLIP
6	GARLAND	70	9B	31B	4	E GRAND AVE.			1	7	11	SLIP
6	GARLAND	70	9B	33B	5	WESTINGHOUSE DR.	22		1	35	38	LOOP
6	GARLAND	70	9B	34B	5	WESTINGHOUSE DR.	35		1	13	18	MODIFIED DIAMOND
6	GARLAND	270	5	112	1	270/ALBERT PIKE RD.			1	10	9	TYPICAL DIAMOND
6	GARLAND	270	5	113	N/A	270/ALBERT PIKE RD.	45		1	9	3	MODIFIED DIAMOND
6	GARLAND	270	5	115	N/A	270/ALBERT PIKE RD.			1	54	14	LOOP
6	GARLAND	270	5	116	2	70B	22	17	1	20	19	TYPICAL DIAMOND
6	GARLAND	270	5	121	2	70B	27	16	1	13	11	TYPICAL DIAMOND
6	GARLAND	270	5	125	3	McLEOD ST.	28	25	1	14	13	TYPICAL DIAMOND
6	GARLAND	270	5	128	3	McLEOD ST.	17	15	1	13	11	TYPICAL DIAMOND
6	GARLAND	270	5	135	4	88	26	20	1	16	15	TYPICAL DIAMOND
6	GARLAND	270	6	145	5B	7			1	8	7	TYPICAL DIAMOND
6	GARLAND	270	6	147	5A	7		22	1	15	15	TYPICAL DIAMOND
6	GARLAND	270	6	151	5B	7		28	1	14	13	TYPICAL DIAMOND
6	GARLAND	270	6	153	5A	7			1	9	7	TYPICAL DIAMOND
6	GARLAND	270	6	157	7	128		28	1	14	12	TYPICAL DIAMOND
6	GARLAND	270	5	176	4	88		15	1	10	11	TYPICAL DIAMOND
6	GARLAND	270	6	183	7	128	17	15	1	16	15	TYPICAL DIAMOND
6	GARLAND	270	6	EB off ramp	9	270/270B		22	1	18	17	TYPICAL DIAMOND
SUBTOTALS GARLAND COUNTY:							281	240	24	357	327	
6	HOT SPRING	30	21	268	83	283	17	17	1	17	16	TYPICAL DIAMOND
6	HOT SPRING	30	21	273	83	283	18	17	1	17	18	TYPICAL DIAMOND
6	HOT SPRING	30	21	278	91	84/MIDWAY RD.	35		1	30	28	MODIFIED DIAMOND
6	HOT SPRING	30	21	282	91	84/MIDWAY RD.	23		1	15	22	LOOP
6	HOT SPRING	30	21	292	97	84	18	15	1	29	28	MODIFIED DIAMOND
6	HOT SPRING	30	21	296	97	84	19	15	1	19	18	TYPICAL DIAMOND
6	HOT SPRING	30	21	301	98 A	270 B			1	17	22	LOOP
6	HOT SPRING	30	21	304	98 B	270 B			1	19	35	LOOP
6	HOT SPRING	30	21	305	98 B	270 B		16	1	25	36	LOOP
6	HOT SPRING	30	21	308	98 A	270 B			1	15	19	LOOP
6	HOT SPRING	30	21	309	99	270	32	16	1	30	32	MODIFIED DIAMOND
6	HOT SPRING	30	21	313	99	270	34		1	28	30	MODIFIED DIAMOND
6	HOT SPRING	30	21	588	REST AREA	REST AREA			1	11	20	MODIFIED DIAMOND
6	HOT SPRING	30	21	591	REST AREA	REST AREA			1	9	13	TYPICAL DIAMOND
SUBTOTALS HOT SPRING COUNTY:							196	96	14	281	337	
6	LONOKE	40	41	559	165	501	27	30	1	19	19	MODIFIED DIAMOND
6	LONOKE	40	41	561	173	89	15	54	1	20	20	MODIFIED DIAMOND
6	LONOKE	40	41	563	165	501	30	36	1	22	22	MODIFIED DIAMOND
6	LONOKE	40	41	566	169	15	26	26	1	25	25	MODIFIED DIAMOND
6	LONOKE	40	41	571	169	15	22	34	1	24	24	MODIFIED DIAMOND
6	LONOKE	40	41	575	N/A	WEIGH STATION						TYPICAL DIAMOND
6	LONOKE	40	41	576	N/A	WEIGH STATION						TYPICAL DIAMOND
6	LONOKE	40	41	577	175	31	18	18	1	19	19	MODIFIED DIAMOND
6	LONOKE	40	41	581	175	31	30	45	1	28	28	MODIFIED DIAMOND
6	LONOKE	40	41	585	183	13	24	30	1	21	21	LOOP
6	LONOKE	40	41	589	183	13	16	25	1	40	40	MODIFIED DIAMOND
6	LONOKE	40	41	593	173	89	38	32	1	25	25	MODIFIED DIAMOND
6	LONOKE	67	11	204	16A	5	*	*	*	*	*	TYPICAL DIAMOND
6	LONOKE	67	11	205	16B	5			1	16	16	LOOP
6	LONOKE	67	11	208	16	5	50	40	1	16	16	TYPICAL DIAMOND
6	LONOKE	67	11	213	19	89		70	1	21	21	TYPICAL DIAMOND
6	LONOKE	67	11	214	19	89	26	54	1	55	55	TYPICAL DIAMOND
6	LONOKE	67	11	217	19	89	30		1	16	16	LOOP
6	LONOKE	67	11	222	22	305	26	40	1	26	26	TYPICAL DIAMOND
6	LONOKE	67	11	226	22	305	34	60	1	25	25	TYPICAL DIAMOND
6	LONOKE	67	11	232	25	319	32	32	1	23	23	TYPICAL DIAMOND
6	LONOKE	67	11	236	25	319	26	44	1	22	22	TYPICAL DIAMOND
SUBTOTALS LONOKE COUNTY:							470	670	19	463	463	
6	PRAIRIE	40	42	599	193	63	50	16	1	19	19	MODIFIED DIAMOND
6	PRAIRIE	40	42	602	193	11	40	22	1	20	20	MODIFIED DIAMOND
6	PRAIRIE	40	42	615	202	33	48	24	1	23	23	MODIFIED DIAMOND
6	PRAIRIE	40	42	617	202	33	44	18	1	23	23	MODIFIED DIAMOND
SUBTOTALS PRAIRIE COUNTY:							182	80	4	85	85	

NOTE: REFER TO SHS MANUAL FOR DIMENSIONS FOR THERMOPLASTIC WRONG-WAY PAVEMENT ARROWS, THERMOPLASTIC WRONG-WAY PAVEMENT ARROWS SHALL BE PAID FOR UNDER "THERMOPLASTIC PAVEMENT MARKING (ARROWS)".  
 \* NO COUNTERMEASURES TO BE PLACED HERE DUE TO UPCOMING JOB

r012260.dgn Quantities

12/8/16

DISTRICT 6  
QUANTITIES

DATE REVISED	DATE FILMED	DATE REVISED	DATE FILMED	FED. RD. DIST. NO.	STATE	FED. AID PROJ. NO.	SHEET NO.	TOTAL SHEETS
12/13/16				6	ARK.			
				JOB NO.		012260	37	61

② QUANTITIES



STOP LINES, WRONG-WAY ARROWS, AND RAMP DELINEATORS (BOX 2 OF 4)

DISTRICT	COUNTY	ROUTE	MAIN LANE SECTION	RAMP SECTION	EXIT NUMBER	CROSS ROAD	STOP LINES	YIELD LINES	THERMO. WRONG-WAY PAVEMENT ARROWS	DELINEATOR (TYPE 2) YELLOW	DELINEATOR (TYPE 2) WHITE	TYPE OF RAMP
							LIN. FT.	LIN. FT.	EACH	EACH	EACH	
6	PULASKI	30	23	407	126	ALEXANDER RD.			1	144	140	SLIP
6	PULASKI	30	23	426	128	MABELVALE W. RD./ OTTER CREEK			1	32	26	SLIP
6	PULASKI	30	23	442	130	338			1	29	24	SLIP
6	PULASKI	30	23	453	130	338			1	29	16	SLIP
6	PULASKI	30	23	454	131	CHICOT RD.			1	30	22	SLIP
6	PULASKI	30	23	455	131	McDANIEL DR.			1	21	16	SLIP
6	PULASKI	30	23	468	133	GEYER SPRINGS RD.			1	21	16	SLIP
6	PULASKI	30	23	471	132	70/UNIVERSITY AVE.	12	12	1	69	59	LOOP
6	PULASKI	30	23	479	133	GEYER SPRINGS RD.	32	24	1	100	98	TYPICAL DIAMOND
6	PULASKI	30	23	483	134	SCOTT HAMILTON DR.			1	35	30	SLIP
6	PULASKI	30	23	493	134	SCOTT HAMILTON DR.			1	40	30	SLIP
6	PULASKI	30	23	494	135	65th ST.	32	24	1	62	60	SLIP
6	PULASKI	30	23	501	135	65th ST.	32	24	1	38	34	TYPICAL DIAMOND
6	PULASKI	30	23	508	139 A	ROOSEVELT RD.		24	1	34	30	SLIP
6	PULASKI	30	23	511	139 A	ROOSEVELT RD.			1	31	29	SLIP
6	PULASKI	30	23	514	140 A	9th ST.		24	1	40	37	SLIP
6	PULASKI	30	23	518	140 A	9th ST.		24	1	24	22	SLIP
6	PULASKI	30	23	521	140 B	6th ST.		24	1	25	23	SLIP
6	PULASKI	30	23	525	141 A	10		12	1	106	102	LOOP
6	PULASKI	30	23	534	141 B	70/BROADWAY ST.		16	1	38	36	SLIP
6	PULASKI	30	23	536	141 B	70/BROADWAY ST.	12	24	1	34	32	SLIP
6	PULASKI	30	23	539	142	CURTIS SYKES DR.		12	1	36	34	SLIP
6	PULASKI	30	23	604	142	CURTIS SYKES DR.		12	1	46	42	SLIP
6	PULASKI	30	23	609	141 A	2nd ST.	15	25	1			LOOP
6	PULASKI	30	23	612	132	70/UNIVERSITY AVE.			1			MODIFIED DIAMOND
6	PULASKI	40	33	461	142	365	22	40	1	19	19	MODIFIED DIAMOND
6	PULASKI	40	33	465	142	365	22	55	1	18	18	MODIFIED DIAMOND
6	PULASKI	40	33	483	148	CRYSTAL HILL RD.	26	22	1	9	9	TYPICAL DIAMOND
6	PULASKI	40	33	487	148	CRYSTAL HILL RD.	22	26	1	15	15	TYPICAL DIAMOND
6	PULASKI	40	33	492	150	MILITARY DR.	23	38	1	12	12	TYPICAL DIAMOND
6	PULASKI	40	33	496	150	MILITARY DR.	20	28	1	16	16	TYPICAL DIAMOND
6	PULASKI	40	33	501	152	365	28	25	1	9	9	TYPICAL DIAMOND
6	PULASKI	40	33	505	152A	W 33rd	26	40	1	22	22	MODIFIED DIAMOND
6	PULASKI	40	33	507	152B	365	33		1	31	31	LOOP
6	PULASKI	40	33	509	153A	107	12	32	1	15	15	MODIFIED DIAMOND
6	PULASKI	40	33	536	157	AR 161	60	48	1	20	20	TYPICAL DIAMOND
6	PULASKI	40	33	539	157	AR 161	24	32	1	16	16	TYPICAL DIAMOND
6	PULASKI	40	33	554	161	AR 391	93		1	23	23	MODIFIED DIAMOND
6	PULASKI	40	33	556	161	AR 391	50		1	20	20	MODIFIED DIAMOND
6	PULASKI	40	23	806	153A	107	64		1	14	14	TYPICAL DIAMOND
6	PULASKI	67	10	114	1A	McCAIN BLVD.		16	1	11	11	TYPICAL DIAMOND
6	PULASKI	67	10	115	1B	McCAIN BLVD.	26		1	7	7	MODIFIED DIAMOND
6	PULASKI	67	10	122	2	NB FRONTAGE			1	3	3	TYPICAL DIAMOND
6	PULASKI	67	10	123	1	SB FRONTAGE			1	3	3	TYPICAL DIAMOND
6	PULASKI	67	10	131	3	NB FRONTAGE	28		1	8	8	TYPICAL DIAMOND
6	PULASKI	67	10	134	3	SB FRONTAGE			1	4	4	TYPICAL DIAMOND
6	PULASKI	67	10	135	4	NB FRONTAGE			1	4	4	TYPICAL DIAMOND
6	PULASKI	67	10	139	5	NB FRONTAGE			1	4	4	TYPICAL DIAMOND
6	PULASKI	67	10	146	5	SB FRONTAGE			1	4	4	TYPICAL DIAMOND
6	PULASKI	67	10	157	8	REDMOND RD.	24	50	1	13	13	TYPICAL DIAMOND
6	PULASKI	67	10	162	9	W MAIN STREET			1	5	5	TYPICAL DIAMOND
6	PULASKI	67	10	172	9	WEST FRONTAGE			1	4	4	TYPICAL DIAMOND
6	PULASKI	67	10	181	10A	WEST FRONTAGE	26		1	4	4	TYPICAL DIAMOND
6	PULASKI	67	10	185	10B	EAST FONTAGE	30		1	4	4	TYPICAL DIAMOND
6	PULASKI	67	10	186	10B	WEST FRONTAGE	26		1	4	4	TYPICAL DIAMOND
6	PULASKI	67	10	189	11	EAST FRONTAGE	30		1	8	8	TYPICAL DIAMOND
6	PULASKI	67	10	194	11	WEST FRONTAGE	*	*	*	*	*	TYPICAL DIAMOND
<b>SUBTOTALS:</b>							850	733	56	1413	1307	

NOTE: REFER TO SHS MANUAL FOR DIMENSIONS FOR THERMOPLASTIC WRONG-WAY PAVEMENT ARROWS, THERMOPLASTIC WRONG-WAY PAVEMENT ARROWS SHALL BE PAID FOR UNDER "THERMOPLASTIC PAVEMENT MARKING (ARROWS)".  
 \* NO COUNTERMEASURES TO BE PLACED HERE DUE TO UPCOMING JOB

r012260.dgn Quantities

12/8/16

DISTRICT 6  
QUANTITIES

DATE REVISED	DATE FILMED	DATE REVISED	DATE FILMED	FED. RD. DIST. NO.	STATE	FED. AID PROJ. NO.	SHEET NO.	TOTAL SHEETS
12/13/16				6	ARK.		38	61
				JOB NO.		012260	38	61

② QUANTITIES



STOP LINES, WRONG-WAY ARROWS, AND RAMP DELINEATORS (BOX 3 OF 4)

DISTRICT	COUNTY	ROUTE	MAIN LANE SECTION	RAMP SECTION	EXIT NUMBER	CROSS ROAD	STOP LINES	YIELD LINES	THERMO. WRONG-WAY PAVEMENT ARROWS	DELINEATOR (TYPE 2) YELLOW	DELINEATOR (TYPE 2) WHITE	TYPE OF RAMP
							LIN. FT.	LIN. FT.	EACH	EACH	EACH	
6	PULASKI	430	21	113	1	5	20	24	1	38	34	MODIFIED DIAMOND
6	PULASKI	430	21	117	1	5	20	12	1	39	35	MODIFIED DIAMOND
6	PULASKI	430	21	122	4	300	12	25	1	73	68	TYPICAL DIAMOND
6	PULASKI	430	21	126	4	300	15	12	1	39	34	TYPICAL DIAMOND
6	PULASKI	430	21	131	5	SHACKLEFORD		42	1	44	38	TYPICAL DIAMOND
6	PULASKI	430	21	135	5	SHACKLEFORD	25	32	2	38	32	TYPICAL DIAMOND
6	PULASKI	430	21	163	8	RODNEY PARHAM RD.	24	24	2	66	62	TYPICAL DIAMOND
6	PULASKI	430	21	167	8	RODNEY PARHAM RD.	24		1	38	34	TYPICAL DIAMOND
6	PULASKI	430	21	171	9	10	25	14	1	25	20	TYPICAL DIAMOND
6	PULASKI	430	21	175	9	10			1	26	22	TYPICAL DIAMOND
6	PULASKI	430	21	177	9	10			1	28	27	TYPICAL DIAMOND
6	PULASKI	430	21	181	12	100	24	16	1	44	40	TYPICAL DIAMOND
6	PULASKI	430	21	185	12	100	12		1	44	40	TYPICAL DIAMOND
6	PULASKI	430	21	148	6B	SHACKLEFORD			1	34	28	TYPICAL DIAMOND
6	PULASKI	430	21	194	6B	SHACKLEFORD	30		1	32	26	TYPICAL DIAMOND
6	PULASKI	430	21	614	7	630 EB/BAPTIST HEALTH DR.			2			MODIFIED DIAMOND
6	PULASKI	440	1	116	1	SPRINGER BLVD.	15	15	1			LOOP
6	PULASKI	440	1	118	1	SPRINGER BLVD.	15	15	1			MODIFIED DIAMOND
6	PULASKI	440	1	122	3	BANKHEAD DRIVE	15	15	1	16	7	TYPICAL DIAMOND
6	PULASKI	440	1	126	3	BANKHEAD DRIVE	15	15	1	12	13	TYPICAL DIAMOND
6	PULASKI	440	1	131	4	LINDSEY RD.	15	15	1	18	18	TYPICAL DIAMOND
6	PULASKI	440	1	135	4	LINDSEY RD.	15	15	1	18	18	TYPICAL DIAMOND
6	PULASKI	440	1	139	5	FOURCHE DAM PIKE	15	15	1	13	13	TYPICAL DIAMOND
6	PULASKI	440	1	143	5	FOURCHE DAM PIKE	15	15	1	13	13	TYPICAL DIAMOND
6	PULASKI	440	1	146	7	US 165	15	15	1	26	32	MODIFIED DIAMOND
6	PULASKI	440	1	152	7	US 165	15	15	1	34	47	LOOP
6	PULASKI	440	1	156	8	FAULKNER LAKE RD.	15		1	16	16	TYPICAL DIAMOND
6	PULASKI	440	1	158	8	FAULKNER LAKE RD.	15		1	15	15	TYPICAL DIAMOND
6	PULASKI	440	1	161	10	US 70	15	15	1	20	33	MODIFIED DIAMOND
6	PULASKI	440	1	165	10	US 70	15	15	1	32	54	LOOP
6	PULASKI	440	1	174	12	AR 161	15	15	1	18	19	TYPICAL DIAMOND
6	PULASKI	440	1	178	12	AR 161	15	15	1	18	20	TYPICAL DIAMOND
6	PULASKI	530	1	114	3	338	15	15	1	18	18	TYPICAL DIAMOND
6	PULASKI	530	1	117	3	338	15	45	1	10	10	TYPICAL DIAMOND
6	PULASKI	530	1	128	7	PRATT RD./ 145th ST.	15	15	1	24	26	MODIFIED DIAMOND
6	PULASKI	530	1	132	7	PRATT RD./ 145th ST.	15	15	1	25	26	MODIFIED DIAMOND
6	PULASKI	530	1	136	9	BINGHAM RD.	15	15	1	16	16	TYPICAL DIAMOND
6	PULASKI	530	1	139	9	BINGHAM RD.	15	15	1	15	16	TYPICAL DIAMOND
6	PULASKI	530	3	153	15	HENSLEY ROAD	15	15	1	15	15	TYPICAL DIAMOND
6	PULASKI	530	3	156	15	HENSLEY ROAD	15	15	1	13	13	TYPICAL DIAMOND
6	PULASKI	630	21	116	1A	CUMBERLAND STREET	30	15	1	14	4	SLIP
6	PULASKI	630	21	121	1B	LOUISIANA ST.	45	15	1	11	4	SLIP
6	PULASKI	630	21	126	1A	CENTER ST.		15	1	11	4	SLIP
6	PULASKI	630	21	127	1B	US 70B	45	15	1	10	12	SLIP
6	PULASKI	630	21	131	2A	S CHESTER STREET	30	15	1	13	17	LOOP
6	PULASKI	630	21	135	2A	S CHESTER STREET	30	15	1	8	20	MODIFIED DIAMOND
6	PULASKI	630	21	141	2B	M L KING	15	15	1	12	12	TYPICAL DIAMOND
6	PULASKI	630	21	146	2B	MARSHALL ST.	45	30	1	10	10	SLIP
6	PULASKI	630	21	147	3A	S WOODROW STREET	15	15	1	13	14	TYPICAL DIAMOND
6	PULASKI	630	21	151	3A	S WOODROW STREET	15	15	1		9	TYPICAL DIAMOND
6	PULASKI	630	21	153	3B	S PINE STREET	45	15	1	7	15	SLIP
6	PULASKI	630	21	158	3B	S CEDAR STREET	30	15	1	7	18	SLIP
6	PULASKI	630	21	159	4	FAIR PARK BLVD.	15	15	1	7	16	TYPICAL DIAMOND
6	PULASKI	630	21	164	4	FIR PARK BLVD.	15	15	1	11	24	TYPICAL DIAMOND
6	PULASKI	630	21	168	5A	S UNIVERSITY AVE.			1	12	19	TYPICAL DIAMOND
6	PULASKI	630	21	169	5B	S UNIVERSITY AVE.		15	1	8	18	LOOP
6	PULASKI	630	21	174	5	S UNIVERSITY AVE.	*	*	*	*	*	MODIFIED DIAMOND
6	PULASKI	630	21	176	6A	MISSISSIPPI ST.	*	*	*	*	*	SLIP
6	PULASKI	630	21	177	6A	RODNEY PARHAM RD.	*	*	*	*	*	LOOP
6	PULASKI	630	21	183	6B	JOHN BARROW ROAD	*	*	*	*	*	TYPICAL DIAMOND
6	PULASKI	630	21	187	6B	JOHN BARROW ROAD	*	*	*	*	*	TYPICAL DIAMOND
6	PULASKI	630	21	192	7	630 WB/BAPTIST HEALTH DR.	*	*	*	*	*	MODIFIED DIAMOND
6	PULASKI	630	21	214	N/A	SHACKLEFORD	*	*	*	*	*	TYPICAL DIAMOND
<b>SUBTOTALS:</b>							966	801	59	1167	1214	
<b>SUBTOTALS PULASKI COUNTY:</b>							1816	1534	115	2580	2521	

NOTE: REFER TO SHS MANUAL FOR DIMENSIONS FOR THERMOPLASTIC WRONG-WAY PAVEMENT ARROWS, THERMOPLASTIC WRONG-WAY PAVEMENT ARROWS SHALL BE PAID FOR UNDER "THERMOPLASTIC PAVEMENT MARKING (ARROWS)".

\* NO COUNTERMEASURES TO BE PLACED HERE DUE TO UPCOMING JOB

DATE REVISED	DATE FILMED	DATE REVISED	DATE FILMED	FED. RD. DIST. NO.	STATE	FED. AID PROJ. NO.	SHEET NO.	TOTAL SHEETS
12/13/16				6	ARK.			
				JOB NO.		012260	38A	61

② QUANTITIES



BARRIER WALL DELINEATORS

DISTRICT	COUNTY	ROUTE	SECTION	EXIT NO	CROSS ROAD	BARRIER LENGTH	NUMBER OF BARRIER WALL DELINEATORS
						LIN. FT.	EACH
6	GARLAND	70	9B	5	WESTINGHOUSE DR.	427	43
6	GARLAND	70	9B	5	WESTINGHOUSE DR.	330	33
<b>SUBTOTAL GARLAND COUNTY:</b>							76
6	LONOKE	40	41	173	HWY. 89	376	38
6	LONOKE	67	11	16B	HWY. 5/HWY. 321	443	44
6	LONOKE	67	11	19	HWY. 89	495	49
<b>SUBTOTAL LONOKE COUNTY:</b>							131
6	PULASKI	30	23	132	UNIVERSITY AVE.	190	19
6	PULASKI	30	23	132	UNIVERSITY AVE.	516	52
6	PULASKI	40	33	152B	MACARTHUR/DOYLE VENABLE	325	32
6	PULASKI	40	33	161	HWY. 391	160	16
6	PULASKI	430	21	12	HWY. 100	466	47
6	PULASKI	430	21	12	HWY. 100	447	45
6	PULASKI	440	1	1	HWY. 365/SPRINGER BLVD.	2432	243
6	PULASKI	440	1	1	HWY. 365/SPRINGER BLVD.	3710	371
6	PULASKI	440	1	7	HWY. 165	430	43
6	PULASKI	440	1	7	HWY. 165	517	51
6	PULASKI	440	1	10	HWY. 70	743	74
6	PULASKI	440	1	10	HWY. 70	392	39
<b>SUBTOTAL PULASKI COUNTY:</b>							1032
<b>TOTAL DISTRICT 6:</b>							1239

LANE USE ARROWS

DISTRICT	COUNTY	ROUTE	SECTION	DIRECTION	EXIT NO.	LANE USE ARROWS	TO
						EACH	
6	GARLAND	70	09B	WB	4	2	NORTH FRONTAGE ROAD
6	GARLAND	70	09B	EB	4	2	SOUTH FRONTAGE ROAD
6	GARLAND	70	09B	WB	3	2	NORTH FRONTAGE ROAD
6	GARLAND	70	09B	WB	2	2	NORTH FRONTAGE ROAD
6	GARLAND	70	09B	WB	2	2	SOUTH FRONTAGE ROAD
6	PULASKI	67	10	NB	9	2	MAIN ST./ TP WHITE DR.
6	PULASKI	530	1	NB	3	2	AR 338/WILLY THOMAS RD./DIXON RD.
<b>TOTAL DISTRICT 6:</b>						14	

NOTE: LANE USE ARROWS WILL BE PLACED IN A PAIR (AS SHOWN ON SHEET 6) TO SHOW THE CORRECT TRAFFIC MOVEMENT FOR VEHICLES EXITING THE FREEWAY AND VEHICLES ON THE FRONTAGE ROADS. THE CONTRACTOR SHALL PLACE THE ARROWS, ONE FOR EACH DIRECTION OF TRAVEL, ON TWO-WAY FRONTAGE ROADS DOWNSTREAM FROM A FREEWAY EXIT RAMP. SEE DETAIL ON SHEET NO. 6. LANE USE ARROWS SHALL BE PAID FOR UNDER "THERMOPLASTIC PAVEMENT MARKING (ARROWS)".

LANE EXTENSIONS

DISTRICT	COUNTY	ROUTE	MAIN LANE SECTION	RAMP SECTION	EXIT NO	CROSS ROAD	LENGTH OF LANE EXTENSION
							LIN. FT.
6	GARLAND	270	6	145	5B	7	40
6	GARLAND	270	5	153	5A	7	40
6	GARLAND	70B	9B	33B	5	WESTINGHOUSE DR.	60
6	GARLAND	70B	9B	35B	5	WESTINGHOUSE DR.	45
<b>TOTAL GARLAND COUNTY:</b>							185
6	HOT SPRING	30	21	283	91	84/MIDWAY RD.	70
<b>TOTAL HOT SPRING COUNTY:</b>							70
6	LONOKE	40	41	564	173	89	92
6	LONOKE	40	41	585	183	13	30
6	LONOKE	67	11	215	19	89	56
6	LONOKE	67	11	217	19	89	125
<b>TOTAL LONOKE COUNTY:</b>							303
6	PULASKI	30	23	465	132	70	65
6	PULASKI	30	23	471	132	70	117
6	PULASKI	30	23	525	141A	10	63
6	PULASKI	40	33	498	150	MILITARY DR.	40
6	PULASKI	40	53	507	152B	365	84
6	PULASKI	40	33	557	161	391	50
6	PULASKI	430	21	174	9	10	98
6	PULASKI	440	1	116	1	SPRINGER BLVD.	55
6	PULASKI	440	1	121	1	SPRINGER BLVD.	45
6	PULASKI	440	1	149	7	US 165	60
6	PULASKI	440	1	152	7	US 165	59
6	PULASKI	440	1	163	10	US 70	52
6	PULASKI	440	1	165	10	US 70	53
6	PULASKI	630	21	131	2A	S CHESTER STREET	68
6	PULASKI	630	21	138	2A	S CHESTER STREET	63
6	PULASKI	630	21	177	6A	S RODNEY PARHAM	56
<b>TOTAL PULASKI COUNTY:</b>							1028
<b>TOTAL DISTRICT 6:</b>							1586

NOTE: LANE EXTENSIONS SHALL BE DASHED, 4" WIDE, YELLOW PAVEMENT MARKINGS THAT GUIDE LEFT-TURNING TRAFFIC FROM THE CROSS ROAD TO THE CORRECT RAMP AT A FREEWAY INTERCHANGE. LANE EXTENSIONS SHALL BE PAID FOR UNDER "ENHANCED THERMOPLASTIC PAVEMENT MARKING YELLOW (6)".

STOP LINES, WRONG-WAY ARROWS, AND RAMP DELINEATORS (BOX 4 OF 4)

DISTRICT	COUNTY	ROUTE	MAIN LANE SECTION	RAMP SECTION	EXIT NUMBER	CROSS ROAD	STOP LINES	YIELD LINES	THERMO. WRONG-WAY PAVEMENT ARROWS	DELINEATOR (TYPE 2) YELLOW	DELINEATOR (TYPE 2) WHITE	TYPE OF RAMP
							LIN. FT.	LIN. FT.	EACH	EACH	EACH	
6	SALINE	30	22	318	106	HWY. 67/FAIRPLAY RD.	30	15	1	44	46	MODIFIED DIAMOND
6	SALINE	30	22	323	106	HWY. 67/FAIRPLAY RD.	22	15	1	30	38	MODIFIED DIAMOND
6	SALINE	30	22	337	114	HWY. 67	*	*	*	*	*	SLIP
6	SALINE	30	22	342	114	HWY. 67	*	*	*	*	*	MODIFIED DIAMOND
6	SALINE	30	22	346	116	SOUTH ST.	*	*	*	*	*	SLIP
6	SALINE	30	22	353	116	SOUTH ST.			1	39	43	SLIP
6	SALINE	30	22	355	117	HWY. 35			1	30	34	SLIP
6	SALINE	30	22	364	117	HWY. 35			1	35	39	SLIP
6	SALINE	30	22	365	118	CONGO RD.			1	35	39	SLIP
6	SALINE	30	22	376	118	CONGO RD.			1	42	40	SLIP
6	SALINE	30	22	377	121	ALCOA RD.			1	44	44	SLIP
6	SALINE	30	22	388	121	ALCOA RD.			1	49	49	SLIP
6	SALINE	30	22	392	123	HWY. 183/REYNOLDS RD.			1	40	40	SLIP
6	SALINE	30	22	403	123	HWY. 183/REYNOLDS RD.			1	54	53	SLIP
6	SALINE	30	22	608	126	HWY. 111/ALEXANDER RD.			1	31	29	SLIP
6	SALINE	530	2	146	12	WOODSON LATERAL RD.	15	15	1	17	18	TYPICAL DIAMOND
6	SALINE	530	2	149	12	WOODSON LATERAL RD.	15	15	1	18	18	TYPICAL DIAMOND
<b>SUBTOTALS SALINE COUNTY:</b>							82	60	14	508	530	
<b>TOTALS DISTRICT 6:</b>							3027	2680	190	4274	4263	

NOTE: REFER TO SHS MANUAL FOR DIMENSIONS FOR THERMOPLASTIC WRONG-WAY PAVEMENT ARROWS, THERMOPLASTIC WRONG-WAY PAVEMENT ARROWS SHALL BE PAID FOR UNDER "THERMOPLASTIC PAVEMENT MARKING (ARROWS)".  
\* NO COUNTERMEASURES TO BE PLACED HERE DUE TO UPCOMING JOB

r012260.dgn Quantities

8/1/16

DISTRICT 6 QUANTITIES

DATE REVISED	DATE FILMED	DATE REVISED	DATE FILMED	FED. DIST. NO.	STATE	FED. AID PROJ. NO.	SHEET NO.	TOTAL SHEETS
				6	ARK.			
						JOB NO.	012260	39 61

② QUANTITIES



DISTRICT 7  
CLARK COUNTY

ROUTE	SECT.	LOG MILE (EXIT NO.) DIRECTION	SIGNS	LOCATION AND SIZE			TOTAL SIGNS	
				LEFT	RIGHT	FAR RIGHT	NO.	SQ. FT.
30	14	54 E.B.	STOP	36"	36"		2	18.00
			YIELD			48"	1	7.00
			DO NOT ENTER	30"	30"	30"	3	18.75
			ONE WAY	(2) 12"x 36"	(2) 12"x 36"		4	12.00
			WRONG WAY	30"x 42"	30"x 42"		2	17.50
			KEEP RIGHT					
30	14	54 W.B.	STOP	36"	36"		2	18.00
			YIELD			48"	1	7.00
			DO NOT ENTER	30"	30"	30"	3	18.75
			ONE WAY	(2) 12"x 36"	(2) 12"x 36"		4	12.00
			WRONG WAY	30"x 42"	30"x 42"		2	17.50
			KEEP RIGHT					
30	14	63 E.B.	STOP	48"	48"		2	32.00
			YIELD			48"	1	7.00
			DO NOT ENTER		36"	30"	1/1	15.25
			ONE WAY		(2) 18"x 54"		2	6.00
			WRONG WAY	30"x 42"	30"x 42"		2	17.50
			KEEP RIGHT	24"x 30"			1	5.00
30	14	63 W.B.	STOP	48"	48"		2	32.00
			YIELD			48"	1	7.00
			DO NOT ENTER		36"	30"	1/1	15.25
			ONE WAY		(2) 18"x 54"		2	6.00
			WRONG WAY	30"x 42"	30"x 42"		2	17.50
			KEEP RIGHT	24"x 30"			1	5.00
30	14	69 E.B.	STOP	36"	36"		2	18.00
			YIELD			48"	1	7.00
			DO NOT ENTER	30"	30"	30"	3	18.75
			ONE WAY	(2) 12"x 36"	(2) 12"x 36"		4	12.00
			WRONG WAY	30"x 42"	30"x 42"		2	17.50
			KEEP RIGHT					
30	14	69 W.B.	STOP	36"	36"		2	18.00
			YIELD			48"	1	7.00
			DO NOT ENTER	30"	30"	30"	3	18.75
			ONE WAY	(2) 12"x 36"	(2) 12"x 36"		4	12.00
			WRONG WAY	30"x 42"	30"x 42"		2	17.50
			KEEP RIGHT					
<b>SUBTOTAL:</b>								458.50

DISTRICT 7  
CLARK COUNTY

ROUTE	SECT.	LOG MILE (EXIT NO.) DIRECTION	SIGNS	LOCATION AND SIZE			TOTAL SIGNS	
				LEFT	RIGHT	FAR RIGHT	NO.	SQ. FT.
30	14	73 E.B.	STOP	48"	48"		2	32.00
			YIELD			48"	1	7.00
			DO NOT ENTER	36"	36"	30"	2/1	24.25
			ONE WAY	(2) 18"x 54"	(2) 18"x 54"		4	27.00
			WRONG WAY	30"x 42"	30"x 42"		2	17.50
			KEEP RIGHT					
30	14	73 W.B.	STOP			48"	1	7.00
			YIELD			48"	1	7.00
			DO NOT ENTER	36"	36"	30"	2/1	24.25
			ONE WAY	(2) 18"x 54"	(2) 18"x 54"		4	27.00
			WRONG WAY	30"x 42"	30"x 42"		2	17.50
			KEEP RIGHT					
30	14	78 E.B.	STOP			48"	1	7.00
			YIELD			48"	1	7.00
			DO NOT ENTER	36"	36"	30"	2/1	24.25
			ONE WAY	(2) 18"x 54"	(2) 18"x 54"		4	27.00
			WRONG WAY	30"x 42"	30"x 42"		2	17.50
			KEEP RIGHT					
30	14	78 W.B.	STOP			48"	1	7.00
			YIELD			48"	1	7.00
			DO NOT ENTER	36"	36"	30"	2/1	24.25
			ONE WAY	(2) 18"x 54"	(2) 18"x 54"		4	27.00
			WRONG WAY	30"x 42"	30"x 42"		2	17.50
			KEEP RIGHT					
<b>SUBTOTAL:</b>								335.00
<b>TOTAL CLARK COUNTY:</b>								793.50

DISTRICT 7  
UNION COUNTY

ROUTE	SECT.	LOG MILE (EXIT NO.) DIRECTION	SIGNS	LOCATION AND SIZE			TOTAL SIGNS	
				LEFT	RIGHT	FAR RIGHT	NO.	SQ. FT.
82	5	17 W.B.	STOP	48"	48"		2	32.00
			YIELD			48"	1	7.00
			DO NOT ENTER	36"	36"	30"	2/1	24.25
			ONE WAY	(2) 18"x 54"	(2) 18"x 54"		4	27.00
			WRONG WAY	30"x 42"	30"x 42"		2	17.50
			KEEP RIGHT					
82	5	18 E.B.	STOP	36"	36"		2	18.00
			YIELD			48"	1	7.00
			DO NOT ENTER	30"	30"	30"	3	18.75
			ONE WAY	(2) 12"x 36"	(2) 12"x 36"		4	27.00
			WRONG WAY	30"x 42"	30"x 42"		2	17.50
			KEEP RIGHT					
82	5	18 W.B.	STOP	36"	36"		2	18.00
			YIELD			48"	1	7.00
			DO NOT ENTER	30"	30"	30"	3	18.75
			ONE WAY	(2) 12"x 36"	(2) 12"x 36"		4	27.00
			WRONG WAY	30"x 42"	30"x 42"		2	17.50
			KEEP RIGHT					
82	5	19 E.B.	STOP	36"	36"		2	18.00
			YIELD			48"	1	7.00
			DO NOT ENTER	30"	30"	30"	3	18.75
			ONE WAY	(2) 12"x 36"	(2) 12"x 36"		4	27.00
			WRONG WAY	30"x 42"	30"x 42"		2	17.50
			KEEP RIGHT					
82	5	19 W.B.	STOP	36"	36"		2	18.00
			YIELD			48"	1	7.00
			DO NOT ENTER	30"	30"	30"	3	18.75
			ONE WAY	(2) 12"x 36"	(2) 12"x 36"		4	27.00
			WRONG WAY	30"x 42"	30"x 42"		2	17.50
			KEEP RIGHT					
82	5	22 E.B.	STOP			48"	1	7.00
			YIELD			48"	1	7.00
			DO NOT ENTER	36"	36"	30"	2/1	24.25
			ONE WAY	(2) 18"x 54"	(2) 18"x 54"		4	27.00
			WRONG WAY	30"x 42"	30"x 42"		2	17.50
			KEEP RIGHT					
<b>SUBTOTAL:</b>								536.50

NOTE: RED VERTICAL STRIPS SHALL BE PLACED ON ALL WRONG-WAY & DO NOT ENTER SIGN POSTS.

DATE REVISED	DATE FILMED	DATE REVISED	DATE FILMED	FED. RD. DIST. NO.	STATE	FED. AID PROJ. NO.	SHEET NO.	TOTAL SHEETS
12/13/16				6	ARK.			
				JOB NO.		012260	40	61

② QUANTITIES



**BARRIER WALL DELINEATORS**

DISTRICT	COUNTY	ROUTE	SECTION	EXIT NO	CROSS ROAD	BARRIER LENGTH	NUMBER OF BARRIER WALL DELINEATORS
						LIN. FT.	EACH
7	UNION	167	1	N/A	HWY. 167/HWY. 167B	981	98
<b>TOTAL DISTRICT 7:</b>							98

**DISTRICT 7  
UNION COUNTY**

ROUTE	SECT.	LOG MILE (EXIT NO.) DIRECTION	SIGNS	LOCATION AND SIZE			TOTAL SIGNS	
				LEFT	RIGHT	FAR RIGHT	NO.	SQ. FT.
82	5	22 W.B.	STOP			48"	1	7.00
			YIELD			30"	2	14.00
			DO NOT ENTER	36"	36"	30"	2/1	24.25
			ONE WAY	(2) 18"x 54"	(2) 18"x 54"		4	27.00
			WRONG WAY	30"x 42"	30"x 42"		2	17.50
167	1	167B & 82B N.B.	STOP	48"	48"		2	32.00
			YIELD			48"	1	7.00
			DO NOT ENTER	36"	36"	30"	2/1	24.25
			ONE WAY	(2) 18"x 54"	(2) 18"x 54"		4	27.00
			WRONG WAY	30"x 42"	30"x 42"		2	17.50
167	1	167B & 82B S.B.	STOP	48"	48"		2	32.00
			YIELD			48"	1	7.00
			DO NOT ENTER	36"	36"	30"	2/1	24.25
			ONE WAY	(2) 18"x 54"	(2) 18"x 54"		4	27.00
			WRONG WAY	30"x 42"	30"x 42"		2	17.50
167	1	U.S. 63 N.B.	STOP	48"	48"		2	32.00
			YIELD					
			DO NOT ENTER	36"	36"		2	18.00
			ONE WAY	(2) 18"x 54"	(2) 18"x 54"		4	27.00
			WRONG WAY	30"x 42"	30"x 42"		3	26.25
167	1	U.S. 63 S.B.	STOP	48"	48"		2	32.00
			YIELD					
			DO NOT ENTER	36"	36"		2	18.00
			ONE WAY	(2) 18"x 54"	(2) 18"x 54"		4	27.00
			WRONG WAY	30"x 42"	30"x 42"		2	17.50
<b>SUBTOTAL:</b>							<b>489.00</b>	
<b>TOTAL UNION COUNTY:</b>							<b>1025.50</b>	
<b>TOTAL DISTRICT 7:</b>							<b>1819.00</b>	

**LANE EXTENSIONS**

DISTRICT	COUNTY	ROUTE	MAIN LANE SECTION	RAMP SECTION	EXIT NO	CROSS ROAD	LENGTH OF LANE EXTENSION
							LIN. FT.
7	CLARK	30	14	224	63	53	20
7	CLARK	30	14	226	63	53	20
7	UNION	167	1	173	N/A	7	25
<b>TOTAL DISTRICT 7:</b>							65

NOTE: LANE EXTENSIONS SHALL BE DASHED, 4" WIDE, YELLOW PAVEMENT MARKINGS THAT GUIDE LEFT-TURNING TRAFFIC FROM THE CROSS ROAD TO THE CORRECT RAMP AT A FREEWAY INTERCHANGE. LANE EXTENSIONS SHALL BE PAID FOR UNDER "THERMOPLASTIC PAVEMENT MARKING YELLOW (6")."

**STOP LINES, WRONG-WAY ARROWS, AND RAMP DELINEATORS**

DISTRICT	COUNTY	ROUTE	MAIN LANE SECTION	RAMP SECTION	EXIT NUMBER	CROSS ROAD	STOP LINES	YIELD LINES	THERMO. WRONG-WAY PAVEMENT ARROWS	DELINEATOR (TYPE 2) YELLOW	DELINEATOR (TYPE 2) WHITE	TYPE OF RAMP
							LIN. FT.	LIN. FT.	EACH	EACH	EACH	
7	CLARK	30	14	209	54	51	30	15	1	26	23	MODIFIED DIAMOND
7	CLARK	30	14	213	54	51	30	15	1	28	25	MODIFIED DIAMOND
7	CLARK	30	14	222	63	53	17	17	1	27	24	MODIFIED DIAMOND
7	CLARK	30	14	226	63	53	17	17	1	9	35	LOOP
7	CLARK	30	14	233	69	26	17	14	1	20	23	MODIFIED DIAMOND
7	CLARK	30	14	237	69	26	16	15	1	20	23	MODIFIED DIAMOND
7	CLARK	30	14	244	73	8	30	12	1	22	21	TYPICAL DIAMOND
7	CLARK	30	14	249	73	8	20	20	1	21	20	TYPICAL DIAMOND
7	CLARK	30	14	254	78	7	14	14	1	13	12	TYPICAL DIAMOND
7	CLARK	30	14	258	78	7	14	14	1	16	16	TYPICAL DIAMOND
7	CLARK	30	12	583	REST AREA	REST AREA			1			TYPICAL DIAMOND
7	CLARK	30	14	605	REST AREA	REST AREA			1			TYPICAL DIAMOND
<b>SUBTOTALS CLARK COUNTY:</b>							205	153	12	202	222	
7	UNION	82	5	314	17	82B	17	21	1	17	16	TYPICAL DIAMOND
7	UNION	82	5	315	18	15	20	16	1	16	16	TYPICAL DIAMOND
7	UNION	82	5	319	18	15	17	24	1	16	15	TYPICAL DIAMOND
7	UNION	82	5	324	19	SOUTHFIELD RD.	19	17	1	12	12	TYPICAL DIAMOND
7	UNION	82	5	328	19	SOUTHFIELD RD.	19	17	1	17	16	TYPICAL DIAMOND
7	UNION	82	5	333	22	167	20	20	1	14	13	TYPICAL DIAMOND
7	UNION	82	5	337	22	167	16	16	1	15	15	TYPICAL DIAMOND
7	UNION	167	1	165	17	CHAMPAGNOLLE RD.	50	15	1	21	20	TYPICAL DIAMOND
7	UNION	167	1	167	17	CHAMPAGNOLLE RD.	32	12	1	20	20	TYPICAL DIAMOND
7	UNION	167	1	174	N/A	7/167/167B	15	22	1	15	25	MODIFIED DIAMOND
7	UNION	167	1	176	N/A	7/167/167B	14	21	1	24	28	TYPICAL DIAMOND
7	UNION	167	1	518	16	63	62		1	15	14	TYPICAL DIAMOND
7	UNION	167	1	522	16	63	62		1	16	15	TYPICAL DIAMOND
7	UNION	167	1	523	15	BUS 82	22	15	1	13	12	TYPICAL DIAMOND
7	UNION	167	1	525	15	BUS 82	32		1	11	11	TYPICAL DIAMOND
<b>SUBTOTALS UNION COUNTY:</b>							417	216	15	242	248	
<b>TOTALS DISTRICT 7:</b>							622	369	27	444	470	

NOTE: REFER TO SHS MANUAL FOR DIMENSIONS FOR THERMOPLASTIC WRONG-WAY PAVEMENT ARROWS, THERMOPLASTIC WRONG-WAY PAVEMENT ARROWS SHALL BE PAID FOR UNDER "THERMOPLASTIC PAVEMENT MARKING (ARROWS)".

NOTE: RED VERTICAL STRIPS SHALL BE PLACED ON ALL WRONG-WAY & DO NOT ENTER SIGN POSTS.

r012260.dgn Quantities

12/8/16

DISTRICT 7  
QUANTITIES

DATE REVISED	DATE FILMED	DATE REVISED	DATE FILMED	FED. RD. DIST. NO.	STATE	FED. AID PROJ. NO.	SHEET NO.	TOTAL SHEETS
				6	ARK.			
				JOB NO.	012260		41	61

② QUANTITIES



DISTRICT 8  
POPE COUNTY

ROUTE	SECT.	LOG MILE (EXIT NO.) DIRECTION	SIGNS	LOCATION AND SIZE			TOTAL SIGNS	
				LEFT	RIGHT	FAR RIGHT	NO.	SQ. FT.
40	22	74 E.B.	STOP	36"	36"		2	18.00
			YIELD			48"	1	7.00
			DO NOT ENTER	30"	30"	30"	3	18.75
			ONE WAY	(2) 12"x 36"	(2) 12"x 36"		4	12.00
			WRONG WAY	30"x 42"	30"x 42"		2	17.50
			KEEP RIGHT					
40	22	74 W.B.	STOP	36"	36"		2	18.00
			YIELD			(2) 48"	2	14.00
			DO NOT ENTER	30"	30"	(2) 30"	4	25.00
			ONE WAY	(2) 12"x 36"	(2) 12"x 36"	(2) 12"x 36"	6	18.00
			WRONG WAY	30"x 42"	30"x 42"		2	17.50
			KEEP RIGHT					
40	22	78 E.B.	STOP	36"	36"		2	18.00
			YIELD					
			DO NOT ENTER	30"	30"		2	12.50
			ONE WAY	(2) 12"x 36"	(2) 12"x 36"		4	12.00
			WRONG WAY	30"x 42"	30"x 42"		2	17.50
			KEEP RIGHT					
40	22	78 W.B.	STOP	36"	36"		2	18.00
			YIELD					
			DO NOT ENTER	30"	30"		2	12.50
			ONE WAY	(2) 12"x 36"	(2) 12"x 36"		4	12.00
			WRONG WAY	30"x 42"	30"x 42"		2	17.50
			KEEP RIGHT					
40	22	81 E.B.	STOP			48"	1	7.00
			YIELD					
			DO NOT ENTER	36"	36"	30"	2/1	24.25
			ONE WAY	(2) 18"x 54"	(2) 18"x 54"		4	12.00
			WRONG WAY	30"x 42"	30"x 42"		2	17.50
			KEEP RIGHT					
40	22	81 W.B.	STOP	36"	36"		2	18.00
			YIELD			48"	1	7.00
			DO NOT ENTER	30"	30"	30"	3	18.75
			ONE WAY	(2) 12"x 36"	(2) 12"x 36"		4	12.00
			WRONG WAY	30"x 42"	30"x 42"		2	17.50
			KEEP RIGHT					
<b>SUBTOTAL:</b>							<b>419.75</b>	

DISTRICT 8  
POPE COUNTY

ROUTE	SECT.	LOG MILE (EXIT NO.) DIRECTION	SIGNS	LOCATION AND SIZE			TOTAL SIGNS	
				LEFT	RIGHT	FAR RIGHT	NO.	SQ. FT.
40	22	83 E.B.	STOP	48"	48"		2	32.00
			YIELD			48"	1	7.00
			DO NOT ENTER	36"	36"	30"	2/1	24.25
			ONE WAY	(2) 18"x 54"	(2) 18"x 54"		4	27.00
			WRONG WAY	30"x 42"	30"x 42"		2	17.50
			KEEP RIGHT					
40	22	83 W.B.	STOP	48"	48"		2	32.00
			YIELD			48"	1	7.00
			DO NOT ENTER	36"	36"	30"	2/1	24.25
			ONE WAY	(2) 18"x 54"	(2) 18"x 54"		4	27.00
			WRONG WAY	30"x 42"	30"x 42"		2	17.50
			KEEP RIGHT					
40	22	84 E.B.	STOP	48"	48"		2	32.00
			YIELD			48"	1	7.00
			DO NOT ENTER	36"	36"	30"	2/1	24.25
			ONE WAY	(2) 18"x 54"	(2) 18"x 54"		4	27.00
			WRONG WAY	30"x 42"	30"x 42"		2	17.50
			KEEP RIGHT					
40	22	84 W.B.	STOP	48"	48"		2	32.00
			YIELD			48"	1	7.00
			DO NOT ENTER	36"	36"	30"	2/1	24.25
			ONE WAY	(2) 18"x 54"	(2) 18"x 54"		4	27.00
			WRONG WAY	30"x 42"	30"x 42"		2	17.50
			KEEP RIGHT					
40	22	88 E.B.	STOP	36"	36"		2	18.00
			YIELD			48"	1	7.00
			DO NOT ENTER	30"	30"	30"	3	18.75
			ONE WAY	(2) 12"x 36"	(2) 12"x 36"		4	12.00
			WRONG WAY	30"x 42"	30"x 42"		2	17.50
			KEEP RIGHT					
40	22	88 W.B.	STOP	48"	48"		2	32.00
			YIELD					
			DO NOT ENTER		36"		1	9.00
			ONE WAY		(2) 18"x 54"		2	13.50
			WRONG WAY	30"x 42"	30"x 42"		2	17.50
			KEEP RIGHT	24"x 30"			1	5.00
<b>SUBTOTAL:</b>							<b>581.25</b>	

DISTRICT 8  
POPE COUNTY

ROUTE	SECT.	LOG MILE (EXIT NO.) DIRECTION	SIGNS	LOCATION AND SIZE			TOTAL SIGNS	
				LEFT	RIGHT	FAR RIGHT	NO.	SQ. FT.
40	22	94 E.B.	STOP	48"	48"		2	32.00
			YIELD					
			DO NOT ENTER		36"		1	9.00
			ONE WAY		(2) 18"x 54"		2	13.50
			WRONG WAY	30"x 42"	30"x 42"		2	17.50
			KEEP RIGHT	24"x 30"			1	5.00
40	22	94 W.B.	STOP	48"	48"		2	32.00
			YIELD					
			DO NOT ENTER		36"		1	9.00
			ONE WAY		(2) 18"x 54"		2	13.50
			WRONG WAY	30"x 42"	30"x 42"		2	17.50
			KEEP RIGHT	24"x 30"			1	5.00
<b>SUBTOTAL:</b>							<b>154.00</b>	
<b>TOTAL POPE COUNTY:</b>							<b>1155.00</b>	

NOTE: RED VERTICAL STRIPS SHALL BE PLACED ON ALL WRONG-WAY & DO NOT ENTER SIGN POSTS.

DATE REVISED	DATE FILED	DATE REVISED	DATE FILED	FED. DIST. NO.	STATE	FED. AID PROJ. NO.	SHEET NO.	TOTAL SHEETS
				6	ARK.			
						JOB NO. 012260	42	61

② QUANTITIES



DISTRICT 8  
JOHNSON COUNTY

ROUTE	SECT.	LOG MILE (EXIT NO.) DIRECTION	SIGNS	LOCATION AND SIZE			TOTAL SIGNS	
				LEFT	RIGHT	FAR RIGHT	NO.	SQ. FT.
40	21	47 E.B.	STOP	48"	48"		2	32.00
			YIELD			48"	1	7.00
			DO NOT ENTER		36"	30"	1/1	15.25
			ONE WAY		(2) 18"x 54"		2	13.50
			WRONG WAY	30"x 42"	30"x 42"		2	17.50
			KEEP RIGHT	24"x 30"			1	5.00
40	21	47 W.B.	STOP	48"	48"		2	32.00
			YIELD			48"	1	7.00
			DO NOT ENTER		36"	30"	1/1	15.25
			ONE WAY		(2) 18"x 54"		2	13.50
			WRONG WAY	30"x 42"	30"x 42"		2	17.50
			KEEP RIGHT	24"x 30"			1	5.00
40	21	55 E.B.	STOP	48"	48"		2	32.00
			YIELD			48"	1	7.00
			DO NOT ENTER		36"	30"	1/1	15.25
			ONE WAY		(2) 18"x 54"		2	13.50
			WRONG WAY	30"x 42"	30"x 42"		2	17.50
			KEEP RIGHT	24"x 30"			1	5.00
40	21	55 W.B.	STOP	36"	36"		2	18.00
			YIELD			48"	1	7.00
			DO NOT ENTER	30"	30"	30"	3	18.75
			ONE WAY	(2) 12"x 36"	(2) 12"x 36"		4	12.00
			WRONG WAY	30"x 42"	30"x 42"		2	17.50
			KEEP RIGHT					
40	21	57 E.B.	STOP	36"	36"		2	18.00
			YIELD			48"	1	7.00
			DO NOT ENTER	30"	30"	30"	3	18.75
			ONE WAY	(2) 12"x 36"	(2) 12"x 36"		4	12.00
			WRONG WAY	30"x 42"	30"x 42"		2	17.50
			KEEP RIGHT					
40	21	57 W.B.	STOP	36"	36"		2	18.00
			YIELD			48"	1	7.00
			DO NOT ENTER	30"	30"	30"	3	18.75
			ONE WAY	(2) 12"x 36"	(2) 12"x 36"		4	12.00
			WRONG WAY	30"x 42"	30"x 42"		2	17.50
			KEEP RIGHT					
<b>SUBTOTAL:</b>							<b>490.50</b>	

DISTRICT 8  
JOHNSON COUNTY

ROUTE	SECT.	LOG MILE (EXIT NO.) DIRECTION	SIGNS	LOCATION AND SIZE			TOTAL SIGNS	
				LEFT	RIGHT	FAR RIGHT	NO.	SQ. FT.
40	21	58 E.B.	STOP					
			YIELD			48"	1	7.00
			DO NOT ENTER		36"	30"	1/1	15.25
			ONE WAY		(2) 18"x 54"		2	13.50
			WRONG WAY	30"x 42"	30"x 42"		2	17.50
			KEEP RIGHT	24"x 30"			1	5.00
40	21	58 W.B.	STOP					
			YIELD			48"	1	7.00
			DO NOT ENTER		36"	30"	1/1	15.25
			ONE WAY		(2) 18"x 54"		2	13.50
			WRONG WAY	30"x 42"	30"x 42"		2	17.50
			KEEP RIGHT	24"x 30"			1	5.00
40	21	64 E.B.	STOP	36"	36"		2	18.00
			YIELD			48"	1	7.00
			DO NOT ENTER	30"	30"	30"	3	18.75
			ONE WAY	(2) 12"x 36"	(2) 12"x 36"		4	12.00
			WRONG WAY	30"x 42"	30"x 42"		2	17.50
			KEEP RIGHT					
40	21	64 W.B.	STOP	36"	36"		2	18.00
			YIELD			48"	1	7.00
			DO NOT ENTER	30"	30"	30"	3	18.75
			ONE WAY	(2) 12"x 36"	(2) 12"x 36"		4	12.00
			WRONG WAY	30"x 42"	30"x 42"		2	17.50
			KEEP RIGHT					
40	21	67 E.B.	STOP	36"	36"		2	18.00
			YIELD			48"	1	7.00
			DO NOT ENTER	30"	30"	30"	3	18.75
			ONE WAY	(2) 12"x 36"	(2) 12"x 36"		4	12.00
			WRONG WAY	30"x 42"	30"x 42"		2	17.50
			KEEP RIGHT					
40	21	67 W.B.	STOP	36"	36"		2	18.00
			YIELD			48"	1	7.00
			DO NOT ENTER	30"	30"	30"	3	18.75
			ONE WAY	(2) 12"x 36"	(2) 12"x 36"		4	12.00
			WRONG WAY	30"x 42"	30"x 42"		2	17.50
			KEEP RIGHT					
<b>SUBTOTAL:</b>							<b>409.50</b>	
<b>TOTAL JOHNSON COUNTY:</b>							<b>900.00</b>	

DISTRICT 8  
CONWAY COUNTY

ROUTE	SECT.	LOG MILE (EXIT NO.) DIRECTION	SIGNS	LOCATION AND SIZE			TOTAL SIGNS	
				LEFT	RIGHT	FAR RIGHT	NO.	SQ. FT.
40	31	101 E.B.	STOP	36"	36"		2	18.00
			YIELD			48"	1	7.00
			DO NOT ENTER	30"	30"	30"	3	18.75
			ONE WAY	(2) 12"x 36"	(2) 12"x 36"		4	12.00
			WRONG WAY	30"x 42"	30"x 42"		2	17.50
			KEEP RIGHT					
40	31	101 W.B.	STOP	36"	36"		2	18.00
			YIELD			48"	1	7.00
			DO NOT ENTER	30"	30"	30"	3	18.75
			ONE WAY	(2) 12"x 36"	(2) 12"x 36"		4	12.00
			WRONG WAY	30"x 42"	30"x 42"		2	17.50
			KEEP RIGHT					
40	31	107 E.B.	STOP	36"	36"		2	18.00
			YIELD			48"	1	7.00
			DO NOT ENTER	30"	30"	30"	3	18.75
			ONE WAY	(2) 12"x 36"	(2) 12"x 36"		4	12.00
			WRONG WAY	30"x 42"	30"x 42"		2	17.50
			KEEP RIGHT					
40	31	107 W.B.	STOP	36"	36"		2	18.00
			YIELD			48"	1	7.00
			DO NOT ENTER	30"	30"	30"	3	18.75
			ONE WAY	(2) 12"x 36"	(2) 12"x 36"		4	12.00
			WRONG WAY	30"x 42"	30"x 42"		2	17.50
			KEEP RIGHT					
40	31	108 E.B.	STOP	36"	36"		2	18.00
			YIELD			48"	1	7.00
			DO NOT ENTER	30"	30"	30"	3	18.75
			ONE WAY	(2) 12"x 36"	(2) 12"x 36"		4	12.00
			WRONG WAY	30"x 42"	30"x 42"		2	17.50
			KEEP RIGHT					
40	31	108 W.B.	STOP					
			YIELD			48"	1	7.00
			DO NOT ENTER	30"	30"	30"	3	18.75
			ONE WAY	(2) 12"x 36"	(2) 12"x 36"		4	12.00
			WRONG WAY	30"x 42"	30"x 42"		2	17.50
			KEEP RIGHT					
<b>SUBTOTAL:</b>							<b>421.50</b>	

NOTE: RED VERTICAL STRIPS SHALL BE PLACED ON ALL WRONG-WAY & DO NOT ENTER SIGN POSTS.

DATE REVISED	DATE FILED	DATE REVISED	DATE FILED	FED. RD. DIST. NO.	STATE	FED. AID PROJ. NO.	SHEET NO.	TOTAL SHEETS
				6	ARK.			
JOB NO. 012260							43	61

② QUANTITIES



DISTRICT 8  
CONWAY COUNTY

ROUTE	SECT.	LOG MILE (EXIT NO.) DIRECTION	SIGNS	LOCATION AND SIZE			TOTAL SIGNS	
				LEFT	RIGHT	FAR RIGHT	NO.	SQ. FT.
40	31	112 E.B.	STOP	36"	36"		2	18.00
			YIELD			48"	1	7.00
			DO NOT ENTER	30"	30"	30"	3	18.75
			ONE WAY	(2) 12"x 36"	(2) 12"x 36"		4	12.00
			WRONG WAY	30"x 42"	30"x 42"		2	17.50
			KEEP RIGHT					
40	31	112 W.B.	STOP			48"	1	7.00
			YIELD					
			DO NOT ENTER	30"	30"	30"	3	18.75
			ONE WAY	(2) 12"x 36"	(2) 12"x 36"		4	12.00
			WRONG WAY	30"x 42"	30"x 42"		2	17.50
			KEEP RIGHT					
40	31	117 E.B.	STOP	36"	36"		2	18.00
			YIELD			48"	1	7.00
			DO NOT ENTER	30"	30"	30"	3	18.75
			ONE WAY	(2) 12"x 36"	(2) 12"x 36"		4	12.00
			WRONG WAY	30"x 42"	30"x 42"		2	17.50
			KEEP RIGHT					
40	31	117 W.B.	STOP			48"	1	7.00
			YIELD					
			DO NOT ENTER	30"	30"	30"	3	18.75
			ONE WAY	(2) 12"x 36"	(2) 12"x 36"		4	12.00
			WRONG WAY	30"x 42"	30"x 42"		2	17.50
			KEEP RIGHT					
SUBTOTAL:							257.00	
TOTAL CONWAY COUNTY:							678.50	

DISTRICT 8  
FAULKNER COUNTY

ROUTE	SECT.	LOG MILE (EXIT NO.) DIRECTION	SIGNS	LOCATION AND SIZE			TOTAL SIGNS	
				LEFT	RIGHT	FAR RIGHT	NO.	SQ. FT.
40	32	124 E.B.	STOP					
			YIELD					
			DO NOT ENTER	30"	30"		2	12.50
			ONE WAY	(2) 12"x 36"	(2) 12"x 36"		4	12.00
			WRONG WAY	30"x 42"	30"x 42"		2	17.50
			KEEP RIGHT					
40	32	124 W.B.	STOP	48"	48"		2	32.00
			YIELD			48"	1	7.00
			DO NOT ENTER	36"	36"	30"	2/1	24.25
			ONE WAY	(2) 18"x 54"	(2) 18"x 54"		4	27.00
			WRONG WAY	30"x 42"	30"x 42"		2	17.50
			KEEP RIGHT					
40	32	125 E.B.	STOP	48"	48"		2	32.00
			YIELD			48"	1	7.00
			DO NOT ENTER	36"	36"	30"	2/1	24.25
			ONE WAY	(2) 18"x 54"	(2) 18"x 54"		4	27.00
			WRONG WAY	30"x 42"	30"x 42"		2	17.50
			KEEP RIGHT					
40	32	125 W.B.	STOP					
			YIELD					
			DO NOT ENTER	36"	36"	36"	2/1	24.25
			ONE WAY	(2) 18"x 54"	(2) 18"x 54"		4	27.00
			WRONG WAY	30"x 42"	30"x 42"		2	17.50
			KEEP RIGHT					
40	32	127 E.B.	STOP			48"	1	7.00
			YIELD					
			DO NOT ENTER	36"	36"	30"	2/1	24.25
			ONE WAY	(2) 18"x 54"	(2) 18"x 54"		4	27.00
			WRONG WAY	30"x 42"	30"x 42"		2	17.50
			KEEP RIGHT					
40	32	127 W.B.	STOP			48"	1	7.00
			YIELD					
			DO NOT ENTER	36"	36"	30"	2/1	24.25
			ONE WAY	(2) 18"x 54"	(2) 18"x 54"		4	27.00
			WRONG WAY	30"x 42"	30"x 42"		2	17.50
			KEEP RIGHT					
SUBTOTAL:							477.75	

DISTRICT 8  
FAULKNER COUNTY

ROUTE	SECT.	LOG MILE (EXIT NO.) DIRECTION	SIGNS	LOCATION AND SIZE			TOTAL SIGNS	
				LEFT	RIGHT	FAR RIGHT	NO.	SQ. FT.
40	32	129 E.B.	STOP					
			YIELD					
			DO NOT ENTER		36"	36"	2	18.00
			ONE WAY		(2) 18"x 54"		2	13.50
			WRONG WAY	30"x 42"	30"x 42"		2	17.50
			KEEP RIGHT					
40	32	129A W.B.	STOP			48"	1	7.00
			YIELD					
			DO NOT ENTER	36"	36"	30"	2/1	24.25
			ONE WAY	(2) 18"x 54"	(2) 18"x 54"		4	27.00
			WRONG WAY	30"x 42"	30"x 42"		2	17.50
			KEEP RIGHT					
40	32	129B W.B.	STOP					
			YIELD					
			DO NOT ENTER		36"	36"	2	18.00
			ONE WAY		(2) 18"x 54"		2	13.50
			WRONG WAY	30"x 42"	30"x 42"		2	17.50
			KEEP RIGHT					
40	32	135 E.B.	STOP	36"	36"		2	18.00
			YIELD			48"	1	7.00
			DO NOT ENTER	30"	30"	30"	3	18.75
			ONE WAY	(2) 12"x 36"	(2) 12"x 36"		4	12.00
			WRONG WAY	30"x 42"	30"x 42"		2	17.50
			KEEP RIGHT					
40	32	135 W.B.	STOP			48"	1	7.00
			YIELD					
			DO NOT ENTER	30"	30"	30"	3	18.75
			ONE WAY	(2) 12"x 36"	(2) 12"x 36"		4	12.00
			WRONG WAY	30"x 42"	30"x 42"		2	17.50
			KEEP RIGHT					
SUBTOTAL:							302.25	
TOTAL FAULKNER COUNTY:							780.00	
TOTAL DISTRICT 8:							3513.50	

NOTE: RED VERTICAL STRIPS SHALL BE PLACED ON ALL WRONG-WAY & DO NOT ENTER SIGN POSTS.

DATE REVISED	DATE FILMED	DATE REVISED	DATE FILMED	FED. RD. DIST. NO.	STATE	FED. AID PROJ. NO.	SHEET NO.	TOTAL SHEETS
12/13/16				6	ARK.			
				JOB NO.		012260	44	61

② QUANTITIES



STOP LINES, WRONG-WAY ARROWS, AND RAMP DELINEATORS

DISTRICT	COUNTY	ROUTE	MAIN LANE SECTION	RAMP SECTION	EXIT NUMBER	CROSS ROAD	STOP LINES	YIELD LINES	THERMO. WRONG-WAY PAVEMENT ARROWS	DELINEATOR (TYPE 2) YELLOW	DELINEATOR (TYPE 2) WHITE	TYPE OF RAMP
							LIN. FT.	LIN. FT.	EACH	EACH	EACH	
8	CONWAY	40	31	352	101	34	19	19	1	12	27	MODIFIED DIAMOND
8	CONWAY	40	31	356	101	34	23	20	1	26	25	MODIFIED DIAMOND
8	CONWAY	40	31	363	107	95	18	17	1	27	29	MODIFIED DIAMOND
8	CONWAY	40	31	367	107	95	18	20	1	19	32	MODIFIED DIAMOND
8	CONWAY	40	31	372	108	9	22	23	1	29	27	TYPICAL DIAMOND
8	CONWAY	40	31	376	108	9	18	17	1	21	21	MODIFIED DIAMOND
8	CONWAY	40	31	387	112	92	17	17	1	14	18	TYPICAL DIAMOND
8	CONWAY	40	31	393	112	92	18	18	1	14	17	TYPICAL DIAMOND
8	CONWAY	40	31	397	117	MENIFEE ACCESS HWY.	18	20	1	23	23	MODIFIED DIAMOND
8	CONWAY	40	31	402	117	MENIFEE ACCESS HWY.	19	22	1	14	25	MODIFIED DIAMOND
SUBTOTALS CONWAY COUNTY:							190	193	10	199	244	
8	FAULKNER	40	32	407	124	25	18	16	1	24	30	MODIFIED DIAMOND
8	FAULKNER	40	32	411	124	25			1	12	37	LOOP
8	FAULKNER	40	32	414	125	65	16	16	1	12	24	MODIFIED DIAMOND
8	FAULKNER	40	32	418	125	65	24	30	1	23	32	TYPICAL DIAMOND
8	FAULKNER	40	32	423	127	64	24	24	1	14	19	TYPICAL DIAMOND
8	FAULKNER	40	32	427	127	64	16	32	1	15	18	TYPICAL DIAMOND
8	FAULKNER	40	32	432	129	286	15	40	1	10	22	MODIFIED DIAMOND
8	FAULKNER	40	32	439	129	286	18	36	1	8	13	LOOP
8	FAULKNER	40	32	443	N/A	TRUCK PARKING			1	8	11	TYPICAL DIAMOND
8	FAULKNER	40	32	444	N/A	TRUCK PARKING			1	8	10	TYPICAL DIAMOND
8	FAULKNER	40	32	445	135	89	18	17	1	13	25	TYPICAL DIAMOND
8	FAULKNER	40	32	449	135	89	16	16	1	25	26	MODIFIED DIAMOND
8	FAULKNER	40	32	792	129	286		23	1			MODIFIED DIAMOND
SUBTOTALS FAULKNER COUNTY:							165	250	13	172	267	
8	JOHNSON	40	21	228	47	164	14	18	1	15	20	MODIFIED DIAMOND
8	JOHNSON	40	21	233	47	164	18	16	1	31	23	LOOP
8	JOHNSON	40	21	241	55	64	20	17	1	20	22	LOOP
8	JOHNSON	40	21	243	55	64	22	16	1	21	13	MODIFIED DIAMOND
8	JOHNSON	40	21	248	57	CRAWFORD ST.	22	19	1	20	22	MODIFIED DIAMOND
8	JOHNSON	40	21	253	57	CRAWFORD ST.	22	22	1	13	31	MODIFIED DIAMOND
8	JOHNSON	40	21	259	58	103	15	20	1	9	23	LOOP
8	JOHNSON	40	21	262	58	103	14	15	1	15	18	MODIFIED DIAMOND
8	JOHNSON	40	21	271	64	64	21	18	1	23	24	MODIFIED DIAMOND
8	JOHNSON	40	21	275	64	64	25	15	1	24	24	MODIFIED DIAMOND
8	JOHNSON	40	21	279	67	315	17	18	1	18	18	MODIFIED DIAMOND
8	JOHNSON	40	21	284	67	315	17	17	1	21	24	MODIFIED DIAMOND
8	JOHNSON	40	21	293	N/A	OVERLOOK		16	1	9	12	TYPICAL DIAMOND
8	JOHNSON	40	21	845	N/A	REST AREA		20	1	8	13	TYPICAL DIAMOND
SUBTOTALS JOHNSON COUNTY:							227	247	14	247	287	
8	POPE	40	22	297	74	333	16	16	1	14	5	TYPICAL DIAMOND
8	POPE	40	22	302	74	333	16	12	1	14	34	TYPICAL DIAMOND
8	POPE	40	22	307	78	MISSION RD.	55		1	18	22	MODIFIED DIAMOND
8	POPE	40	22	309	78	MISSION RD.	76		1	22	34	MODIFIED DIAMOND
8	POPE	40	22	313	81	7	25	28	1	16	21	MODIFIED DIAMOND
8	POPE	40	22	317	81	7	23	38	1	20	20	MODIFIED DIAMOND
8	POPE	40	22	321	83	326	25	42	1	22	24	MODIFIED DIAMOND
8	POPE	40	22	324	83	326	21	18	1	21	25	MODIFIED DIAMOND
8	POPE	40	22	328	84	331	18	33	1	18	22	MODIFIED DIAMOND
8	POPE	40	22	332	84	331	26	33	1	18	23	MODIFIED DIAMOND
8	POPE	40	22	338	88	363	19	21	1	12	14	TYPICAL DIAMOND
8	POPE	40	22	343	88	363	25		1	12	22	LOOP
8	POPE	40	22	346	94	105	16	22	1	6	21	LOOP
8	POPE	40	22	348	94	105	20		1	11	22	MODIFIED DIAMOND
8	POPE	40	22	823	N/A	REST AREA		16	1	11	10	TYPICAL DIAMOND
SUBTOTALS POPE COUNTY:							381	279	15	235	319	
TOTALS DISTRICT 8:							963	969	52	853	1117	

NOTE: REFER TO SHS MANUAL FOR DIMENSIONS FOR THERMOPLASTIC WRONG-WAY PAVEMENT ARROWS, THERMOPLASTIC WRONG-WAY PAVEMENT ARROWS SHALL BE PAID FOR UNDER "THERMOPLASTIC PAVEMENT MARKING (ARROWS)".

BARRIER WALL DELINEATORS

DISTRICT	COUNTY	ROUTE	SECTION	EXIT NO	CROSS ROAD	BARRIER LENGTH	NUMBER OF BARRIER WALL DELINEATORS
						LIN. FT.	EACH
8	FAULKNER	40	32	129	65B/DAVE WARD DR.	1570	157
TOTAL DISTRICT 8:							157

LANE EXTENSIONS

DISTRICT	COUNTY	ROUTE	MAIN LANE SECTION	RAMP SECTION	EXIT NO	CROSS ROAD	LENGTH OF LANE EXTENSION
							LIN. FT.
8	JOHNSON	40	21	231	47	164	20
8	JOHNSON	40	21	233	47	164	27
8	JOHNSON	40	21	241	57	64	23
8	JOHNSON	40	21	259	58	103	28
8	JOHNSON	40	21	264	58	103	39
TOTAL JOHNSON COUNTY:							137
8	POPE	40	22	343	88	363	29
8	POPE	40	22	346	94	105	27
8	POPE	40	22	349	94	105	29
TOTAL POPE COUNTY:							85
TOTAL DISTRICT 8:							222

NOTE: LANE EXTENSIONS SHALL BE DASHED, 4" WIDE, YELLOW PAVEMENT MARKINGS THAT GUIDE LEFT-TURNING TRAFFIC FROM THE CROSS ROAD TO THE CORRECT RAMP AT A FREEWAY INTERCHANGE. LANE EXTENSIONS SHALL BE PAID FOR UNDER "THERMOPLASTIC PAVEMENT MARKING YELLOW (6)".

r012260.dgn Quantities

12/8/16

DATE REVISED	DATE FILMED	DATE REVISED	DATE FILMED	FED. RD. DIST. NO.	STATE	FED. AID PROJ. NO.	SHEET NO.	TOTAL SHEETS
12/13/16				6	ARK.			
							JOB NO.	012260
							45	61

② QUANTITIES



DISTRICT 9  
BENTON COUNTY

ROUTE	SECT.	LOG MILE (EXIT NO.) DIRECTION	SIGNS	LOCATION AND SIZE			TOTAL SIGNS	
				LEFT	RIGHT	FAR RIGHT	NO.	SQ. FT.
49	29	76 N.B.	STOP	48"	48"		2	32.00
			YIELD					
			DO NOT ENTER	36"	36"	36"	3	27.00
			ONE WAY	(2) 18"x 54"	(2) 18"x 54"		4	27.00
			WRONG WAY	30"x 42"	30"x 42"		2	17.50
			KEEP RIGHT					
49	29	76 S.B.	STOP	36"	36"		2	18.00
			YIELD			48"	1	7.00
			DO NOT ENTER	30"	30"	30"	3	18.75
			ONE WAY	(2) 12"x 36"	(2) 12"x 36"		4	12.00
			WRONG WAY	30"x 42"	30"x 42"		2	17.50
			KEEP RIGHT					
49	29	78 N.B.	STOP					
			YIELD					
			DO NOT ENTER	36"	36"	30"	2/1	24.25
			ONE WAY	(2) 18"x 54"	(2) 18"x 54"		4	27.00
			WRONG WAY	30"x 42"	30"x 42"		2	17.50
			KEEP RIGHT					
49	29	78 S.B.	STOP					
			YIELD			48"	1	7.00
			DO NOT ENTER	36"	36"	30"	2/1	24.25
			ONE WAY	(2) 18"x 54"	(2) 18"x 54"		4	12.00
			WRONG WAY	30"x 42"	30"x 42"		2	17.50
			KEEP RIGHT					
49	29	81 N.B.	STOP					
			YIELD					
			DO NOT ENTER	36"	36"	30"	2/1	24.25
			ONE WAY	(2) 18"x 54"	(2) 18"x 54"		4	12.00
			WRONG WAY	30"x 42"	30"x 42"		2	17.50
			KEEP RIGHT					
49	29	81 S.B.	STOP					
			YIELD					
			DO NOT ENTER	36"	36"	30"	2/1	24.25
			ONE WAY	(2) 18"x 54"	(2) 18"x 54"		4	12.00
			WRONG WAY	30"x 42"	30"x 42"		2	17.50
			KEEP RIGHT					
<b>SUBTOTAL:</b>								413.75

DISTRICT 9  
BENTON COUNTY

ROUTE	SECT.	LOG MILE (EXIT NO.) DIRECTION	SIGNS	LOCATION AND SIZE			TOTAL SIGNS	
				LEFT	RIGHT	FAR RIGHT	NO.	SQ. FT.
49	29	82 N.B.	STOP					
			YIELD					
			DO NOT ENTER	36"	36"		2	18.00
			ONE WAY	(2) 18"x 54"	(2) 18"x 54"		4	12.00
			WRONG WAY	30"x 42"	30"x 42"		2	17.50
			KEEP RIGHT					
49	29	82 S.B.	STOP					
			YIELD					
			DO NOT ENTER	36"	36"		2	18.00
			ONE WAY	(2) 18"x 54"	(2) 18"x 54"		4	12.00
			WRONG WAY	30"x 42"	30"x 42"		2	17.50
			KEEP RIGHT					
49	29	83 N.B.	STOP					
			YIELD					
			DO NOT ENTER	36"	36"		2	18.00
			ONE WAY	(2) 18"x 54"	(2) 18"x 54"		4	12.00
			WRONG WAY	30"x 42"	30"x 42"		2	17.50
			KEEP RIGHT					
49	29	83 S.B.	STOP					
			YIELD					
			DO NOT ENTER	36"	36"		2	18.00
			ONE WAY	(2) 18"x 54"	(2) 18"x 54"		4	12.00
			WRONG WAY	30"x 42"	30"x 42"		2	17.50
			KEEP RIGHT					
49	29	85 N.B.	STOP					
			YIELD					
			DO NOT ENTER	36"	36"		2	18.00
			ONE WAY	(2) 18"x 54"	(2) 18"x 54"		4	12.00
			WRONG WAY	30"x 42"	30"x 42"		2	17.50
			KEEP RIGHT					
49	29	85 S.B.	STOP					
			YIELD					
			DO NOT ENTER	36"	36"		2	18.00
			ONE WAY	(2) 18"x 54"	(2) 18"x 54"		4	12.00
			WRONG WAY	30"x 42"	30"x 42"		2	17.50
			KEEP RIGHT					
<b>SUBTOTAL:</b>								285.00

EXIT 62 S.B. IS A SLIP RAMP ONTO A ONE-WAY FRONTAGE ROAD AND IS NOT SUBJECT TO THE REQUIREMENTS OF SECTION 2B.41.

DISTRICT 9  
BENTON COUNTY

ROUTE	SECT.	LOG MILE (EXIT NO.) DIRECTION	SIGNS	LOCATION AND SIZE			TOTAL SIGNS	
				LEFT	RIGHT	FAR RIGHT	NO.	SQ. FT.
549	9	NB to HWY 72	STOP	36"	36"		2	18.00
			YIELD			48"	1	7.00
			DO NOT ENTER	30"	30"	30"	3	18.75
			ONE WAY	(2) 12"x 36"	(2) 12"x 36"		4	12.00
			WRONG WAY	30"x 42"	30"x 42"		2	17.50
			KEEP RIGHT					
549	9	473	STOP	36"	36"		2	18.00
			YIELD			48"	1	7.00
			DO NOT ENTER	30"	30"	30"	3	18.75
			ONE WAY	(2) 12"x 36"	(2) 12"x 36"		4	12.00
			WRONG WAY	30"x 42"	30"x 42"		2	17.50
			KEEP RIGHT					
549	9	474	STOP	36"	36"		2	18.00
			YIELD			48"	1	7.00
			DO NOT ENTER	30"	30"	30"	3	18.75
			ONE WAY	(2) 12"x 36"	(2) 12"x 36"		4	12.00
			WRONG WAY	30"x 42"	30"x 42"		2	17.50
			KEEP RIGHT					
549	9	477	STOP	36"	36"		2	18.00
			YIELD			48"	1	7.00
			DO NOT ENTER	30"	30"	30"	3	18.75
			ONE WAY	(2) 12"x 36"	(2) 12"x 36"		4	12.00
			WRONG WAY	30"x 42"	30"x 42"		2	17.50
			KEEP RIGHT					
549	9	478 NB to Rocky Dell Hollow Rd.	STOP	36"	36"		2	18.00
			YIELD			48"	1	7.00
			DO NOT ENTER	30"	30"	30"	3	18.75
			ONE WAY	(2) 12"x 36"	(2) 12"x 36"		4	12.00
			WRONG WAY	30"x 42"	30"x 42"		2	17.50
			KEEP RIGHT					
<b>SUBTOTAL:</b>								366.25
<b>TOTAL BENTON COUNTY:</b>								1065.00
<b>TOTAL DISTRICT 9:</b>								1763.75

NOTE: RED VERTICAL STRIPS SHALL BE PLACED ON ALL WRONG-WAY & DO NOT ENTER SIGN POSTS.

DATE REVISED	DATE FILMED	DATE REVISED	DATE FILMED	FED. RD. DIST. NO.	STATE	FED. AID PROJ. NO.	SHEET NO.	TOTAL SHEETS
12/13/16				6	ARK.			
JOB NO. 012260							46	61

② QUANTITIES



STOP LINES, WRONG-WAY ARROWS, AND RAMP DELINEATORS

DISTRICT	COUNTY	ROUTE	MAIN LANE SECTION	RAMP SECTION	EXIT NUMBER	CROSS ROAD	STOP LINES	YIELD LINES	THERMO. WRONG-WAY PAVEMENT ARROWS	DELINEATOR (TYPE 2) YELLOW	DELINEATOR (TYPE 2) WHITE	TYPE OF RAMP
							LIN. FT.	LIN. FT.	EACH	EACH	EACH	
9	BENTON	49	29	337	76	WAGON WHEEL RD.	28		1	16	16	TYPICAL DIAMOND
9	BENTON	49	29	342	76	WAGON WHEEL RD.	35	27	1	11	11	TYPICAL DIAMOND
9	BENTON	49	29	352	78	264	54		1	23	23	MODIFIED DIAMOND
9	BENTON	49	29	356	78	264	61		1	17	17	TYPICAL DIAMOND
9	BENTON	49	29	364	81	PLEASANT GROVE RD.	77		1	16	16	MODIFIED DIAMOND
9	BENTON	49	29	366	81	PLEASANT GROVE RD.	40	37	1	19	19	MODIFIED DIAMOND
9	BENTON	49	29	371	82	PAULINE WHITAKER PKWY.	58		1	27	27	MODIFIED DIAMOND
9	BENTON	49	29	375	82	PAULINE WHITAKER PKWY.	66		1	28	28	MODIFIED DIAMOND
9	BENTON	49	29	379	83	NEW HOPE RD.	70		1	14	14	TYPICAL DIAMOND
9	BENTON	49	29	382	83	NEW HOPE RD.	52	20	1	11	11	MODIFIED DIAMOND
9	BENTON	49	29	385	85	71B	28	28	1	14	14	TYPICAL DIAMOND
9	BENTON	49	29	388	85	71B	28	24	1	13	13	TYPICAL DIAMOND
9	BENTON	49	29	392	86	102	*	*	*	*	*	TYPICAL DIAMOND
9	BENTON	49	29	396	86	102	*	*	*	*	*	TYPICAL DIAMOND
9	BENTON	49	29	399	88	72	*	*	*	*	*	MODIFIED DIAMOND
9	BENTON	49	29	402	88	72	*	*	*	*	*	MODIFIED DIAMOND
9	BENTON	549	9	473	SB Exit	72	20	20	1	14	14	MODIFIED DIAMOND
9	BENTON	549	9	N/A	N/A	72	20	20	1	14	14	MODIFIED DIAMOND
9	BENTON	549	9	474	N/A	72	22	20	1	15	15	MODIFIED DIAMOND
9	BENTON	549	9	477	N/A	72	15	15	1	15	15	MODIFIED DIAMOND
10	BENTON	549	9	478	N/A	ROCKY DELL HOLLOW RD.	15	15	1	14	14	MODIFIED DIAMOND
<b>TOTALS DISTRICT 9:</b>							689	226	17	281	281	

NOTE: REFER TO SHS MANUAL FOR DIMENSIONS FOR THERMOPLASTIC WRONG-WAY PAVEMENT ARROWS, THERMOPLASTIC WRONG-WAY PAVEMENT ARROWS SHALL BE PAID FOR UNDER "THERMOPLASTIC PAVEMENT MARKING (ARROWS)".  
 \* THESE LOCATIONS ARE CURRENTLY UNDER CONSTRUCTION AND WRONG-WAY DRIVING COUNTERMEASURES WILL BE ADDED TO THEIR JOB SCOPE

DATE REVISED	DATE FILMED	DATE REVISED	DATE FILMED	FED. RD. DIST. NO.	STATE	FED. AID PROJ. NO.	SHEET NO.	TOTAL SHEETS
				6	ARK.			
JOB NO. 012260							47	61

2 QUANTITIES



DISTRICT 10  
POINSETT COUNTY

ROUTE	SECT.	LOG MILE (EXIT NO.) DIRECTION	SIGNS	LOCATION AND SIZE			TOTAL SIGNS	
				LEFT	RIGHT	FAR RIGHT	NO.	SQ. FT.
555	2	7 N.B.	STOP	36"	36"		2	18.00
			YIELD			48"	1	7.00
			DO NOT ENTER	30"	30"	30"	3	18.75
			ONE WAY	(2) 12"x 36"	(2) 12"x 36"		4	12.00
			WRONG WAY	30"x 42"	30"x 42"		2	17.50
			KEEP RIGHT					
555	2	7 S.B.	STOP	36"	36"		2	18.00
			YIELD			48"	1	7.00
			DO NOT ENTER	30"	30"	30"	3	18.75
			ONE WAY	(2) 12"x 36"	(2) 12"x 36"		4	12.00
			WRONG WAY	30"x 42"	30"x 42"		2	17.50
			KEEP RIGHT					
555	2	8 N.B.	STOP	36"	36"		2	18.00
			YIELD			48"	1	7.00
			DO NOT ENTER	30"	30"	30"	3	18.75
			ONE WAY	(2) 12"x 36"	(2) 12"x 36"		4	12.00
			WRONG WAY	30"x 42"	30"x 42"		2	17.50
			KEEP RIGHT					
555	2	8 S.B.	STOP	48"	48"		2	32.00
			YIELD			48"	1	7.00
			DO NOT ENTER		36"	30"	1/1	15.25
			ONE WAY		(2) 18"x 54"		2	13.50
			WRONG WAY	30"x 42"	30"x 42"		2	17.50
			KEEP RIGHT	24"x 30"			1	5.00
555	2	13 N.B.	STOP	48"	48"		2	32.00
			YIELD			48"	1	7.00
			DO NOT ENTER		36"	30"	1/1	15.25
			ONE WAY		(2) 18"x 54"		2	13.50
			WRONG WAY	30"x 42"	30"x 42"		2	17.50
			KEEP RIGHT	24"x 30"			1	5.00
555	2	13 S.B.	STOP	36"	36"		2	18.00
			YIELD			48"	1	7.00
			DO NOT ENTER	30"	30"	30"	3	18.75
			ONE WAY	(2) 12"x 36"	(2) 12"x 36"		4	12.00
			WRONG WAY	30"x 42"	30"x 42"		2	17.50
			KEEP RIGHT					
<b>SUBTOTAL:</b>							<b>473.50</b>	

DISTRICT 10  
POINSETT COUNTY

ROUTE	SECT.	LOG MILE (EXIT NO.) DIRECTION	SIGNS	LOCATION AND SIZE			TOTAL SIGNS	
				LEFT	RIGHT	FAR RIGHT	NO.	SQ. FT.
555	2	14 N.B.	STOP	36"	36"		2	18.00
			YIELD			48"	1	7.00
			DO NOT ENTER	30"	30"	30"	3	18.75
			ONE WAY	(2) 12"x 36"	(2) 12"x 36"		4	12.00
			WRONG WAY	30"x 42"	30"x 42"		2	17.50
			KEEP RIGHT					
555	2	14 S.B.	STOP	36"	36"		2	18.00
			YIELD			48"	1	7.00
			DO NOT ENTER	30"	30"	30"	3	18.75
			ONE WAY	(2) 12"x 36"	(2) 12"x 36"		4	12.00
			WRONG WAY	30"x 42"	30"x 42"		2	17.50
			KEEP RIGHT					
555	2	18 N.B.	STOP	36"	36"		2	18.00
			YIELD			48"	1	7.00
			DO NOT ENTER	30"	30"	30"	3	18.75
			ONE WAY	(2) 12"x 36"	(2) 12"x 36"		4	12.00
			WRONG WAY	30"x 42"	30"x 42"		2	17.50
			KEEP RIGHT					
555	2	18 S.B.	STOP	36"	36"		2	18.00
			YIELD			48"	1	7.00
			DO NOT ENTER	30"	30"	30"	3	18.75
			ONE WAY	(2) 12"x 36"	(2) 12"x 36"		4	12.00
			WRONG WAY	30"x 42"	30"x 42"		2	17.50
			KEEP RIGHT					
555	2	24 N.B.	STOP	36"	36"		2	18.00
			YIELD			48"	1	7.00
			DO NOT ENTER	30"	30"	30"	3	18.75
			ONE WAY	(2) 12"x 36"	(2) 12"x 36"		4	12.00
			WRONG WAY	30"x 42"	30"x 42"		2	17.50
			KEEP RIGHT					
555	2	24 S.B.	STOP	36"	36"		2	18.00
			YIELD			48"	1	7.00
			DO NOT ENTER	30"	30"	30"	3	18.75
			ONE WAY	(2) 12"x 36"	(2) 12"x 36"		4	12.00
			WRONG WAY	30"x 42"	30"x 42"		2	17.50
			KEEP RIGHT					
<b>SUBTOTAL:</b>							<b>439.50</b>	

DISTRICT 10  
POINSETT COUNTY

ROUTE	SECT.	LOG MILE (EXIT NO.) DIRECTION	SIGNS	LOCATION AND SIZE			TOTAL SIGNS	
				LEFT	RIGHT	FAR RIGHT	NO.	SQ. FT.
555	2	29 N.B.	STOP	36"	36"		2	18.00
			YIELD			48"	1	7.00
			DO NOT ENTER	30"	30"	30"	3	18.75
			ONE WAY	(2) 12"x 36"	(2) 12"x 36"		4	12.00
			WRONG WAY	30"x 42"	30"x 42"		2	17.50
			KEEP RIGHT					
555	2	29 S.B.	STOP	36"	36"		2	18.00
			YIELD			48"	1	7.00
			DO NOT ENTER	30"	30"	30"	3	18.75
			ONE WAY	(2) 12"x 36"	(2) 12"x 36"		4	12.00
			WRONG WAY	30"x 42"	30"x 42"		2	17.50
			KEEP RIGHT					
<b>SUBOTAL:</b>							<b>146.50</b>	
<b>TOTAL POINSETT COUNTY:</b>							<b>1059.50</b>	

NOTE: RED VERTICAL STRIPS SHALL BE PLACED ON ALL WRONG-WAY & DO NOT ENTER SIGN POSTS.

DATE REVISED	DATE FILED	DATE REVISED	DATE FILED	FED. RD. DIST. NO.	STATE	FED. AID PROJ. NO.	SHEET NO.	TOTAL SHEETS
				6	ARK.			
JOB NO.						012260	48	61

② QUANTITIES



DISTRICT 10  
CRAIGHEAD COUNTY

ROUTE	SECT.	LOG MILE (EXIT NO.)	SIGNS	LOCATION AND SIZE			TOTAL SIGNS	
				LEFT	RIGHT	FAR RIGHT	NO.	SQ. FT.
555	3	35 N.B.	STOP	48"	48"		2	32.00
			YIELD			48"	2	14.00
			DO NOT ENTER		36"	30"	1/1	15.25
			ONE WAY		(2) 18"x 54"		2	13.50
			WRONG WAY	30"x 42"	30"x 42"		2	17.50
			KEEP RIGHT	24"x 30"			1	5.00
555	3	35 S.B.	STOP	48"	48"		2	32.00
			YIELD			48"	1	7.00
			DO NOT ENTER		36"	30"	1/1	15.25
			ONE WAY		(2) 18"x 54"		2	13.50
			WRONG WAY	30"x 42"	30"x 42"		2	17.50
			KEEP RIGHT	24"x 30"			1	5.00
555	3	36 N.B.	STOP	36"	36"		2	18.00
			YIELD			48"	1	7.00
			DO NOT ENTER	30"	30"	30"	3	18.75
			ONE WAY	(2) 12"x 36"	(2) 12"x 36"		4	12.00
			WRONG WAY	30"x 42"	30"x 42"		2	17.50
			KEEP RIGHT					
555	3	36 S.B.	STOP	36"	36"		2	18.00
			YIELD			48"	1	7.00
			DO NOT ENTER	30"	30"	30"	3	18.75
			ONE WAY	(2) 12"x 36"	(2) 12"x 36"		4	12.00
			WRONG WAY	30"x 42"	30"x 42"		2	17.50
			KEEP RIGHT					
555	3	39 N.B.	STOP	36"	36"		2	18.00
			YIELD			48"	1	7.00
			DO NOT ENTER	30"	30"	30"	3	18.75
			ONE WAY	(2) 12"x 36"	(2) 12"x 36"		4	12.00
			WRONG WAY	30"x 42"	30"x 42"		2	17.50
			KEEP RIGHT					
555	3	39 S.B.	STOP	36"	36"		2	18.00
			YIELD			48"	1	7.00
			DO NOT ENTER	30"	30"	30"	3	18.75
			ONE WAY	(2) 12"x 36"	(2) 12"x 36"		4	12.00
			WRONG WAY	30"x 42"	30"x 42"		2	17.50
			KEEP RIGHT					
SUBTOTAL:							480.50	

DISTRICT 10  
CRAIGHEAD COUNTY

ROUTE	SECT.	LOG MILE (EXIT NO.)	SIGNS	LOCATION AND SIZE			TOTAL SIGNS	
				LEFT	RIGHT	FAR RIGHT	NO.	SQ. FT.
555	3	40 N.B.	STOP	48"	48"		2	32.00
			YIELD			48"	1	7.00
			DO NOT ENTER		36"	30"	1/1	15.25
			ONE WAY		(2) 18"x 54"		2	13.50
			WRONG WAY	30"x 42"	30"x 42"		2	17.50
			KEEP RIGHT	24"x 30"			1	5.00
555	3	40 S.B.	STOP	48"	48"		2	32.00
			YIELD			48"	1	7.00
			DO NOT ENTER		36"	30"	1/1	15.25
			ONE WAY		(2) 18"x 54"		2	13.50
			WRONG WAY	30"x 42"	30"x 42"		2	17.50
			KEEP RIGHT	24"x 30"			1	5.00
555	3	42 N.B. HWY. 1 & 49	STOP	48"	48"		2	32.00
			YIELD			48"	1	7.00
			DO NOT ENTER	36"	36"	30"	2/1	24.25
			ONE WAY	(2) 18"x 54"	(2) 18"x 54"		4	27.00
			WRONG WAY	30"x 42"	30"x 42"		2	17.50
			KEEP RIGHT					
555	3	42 S.B. HWY. 1 & 49	STOP					
			YIELD			48"	1	7.00
			DO NOT ENTER	36"	36"	30"	2/1	24.25
			ONE WAY	(2) 18"x 54"	(2) 18"x 54"		4	27.00
			WRONG WAY	30"x 42"	30"x 42"		2	17.50
			KEEP RIGHT					
555	3	42 N.B. CARAWAY	STOP	48"	48"		2	32.00
			YIELD			48"	1	7.00
			DO NOT ENTER	36"	36"	30"	2/1	24.25
			ONE WAY	(2) 18"x 54"	(2) 18"x 54"		4	27.00
			WRONG WAY	30"x 42"	30"x 42"		2	17.50
			KEEP RIGHT					
555	3	42 S.B. CARAWAY	STOP					
			YIELD			48"	1	7.00
			DO NOT ENTER		36"	30"	1/1	15.25
			ONE WAY		(2) 18"x 54"		2	13.50
			WRONG WAY	30"x 42"	30"x 42"		2	17.50
			KEEP RIGHT	24"x 30"			1	5.00
SUBTOTAL:							530.00	

DISTRICT 10  
CRAIGHEAD COUNTY

ROUTE	SECT.	LOG MILE (EXIT NO.)	SIGNS	LOCATION AND SIZE			TOTAL SIGNS	
				LEFT	RIGHT	FAR RIGHT	NO.	SQ. FT.
555	3	44 N.B.	STOP	48"	48"		2	32.00
			YIELD			48"	1	7.00
			DO NOT ENTER	36"	36"	30"	2/1	24.25
			ONE WAY	(2) 18"x 54"	(2) 18"x 54"		4	27.00
			WRONG WAY	30"x 42"	30"x 42"		2	17.50
			KEEP RIGHT					
555	3	44 S.B.	STOP	48"	48"		2	32.00
			YIELD			48"	1	7.00
			DO NOT ENTER	36"	36"	30"	2/1	24.25
			ONE WAY	(2) 18"x 54"	(2) 18"x 54"		4	27.00
			WRONG WAY	30"x 42"	30"x 42"		2	17.50
			KEEP RIGHT					
555	3	45 N.B.	STOP	48"	48"		2	32.00
			YIELD			48"	1	7.00
			DO NOT ENTER		36"	30"	1/1	15.25
			ONE WAY		(2) 18"x 54"		2	13.50
			WRONG WAY	30"x 42"	30"x 42"		2	17.50
			KEEP RIGHT	24"x 30"			1	5.00
63	6	45 S.B.	STOP		48"		2	32.00
			YIELD			48"	1	7.00
			DO NOT ENTER	36"	36"	30"	2/1	24.25
			ONE WAY	(2) 18"x 54"	(2) 18"x 54"		4	27.00
			WRONG WAY	30"x 42"	30"x 42"		2	17.50
			KEEP RIGHT					
63	6	46 N.B.	STOP	36"	36"		2	18.00
			YIELD					
			DO NOT ENTER	30"	30"		2	12.50
			ONE WAY	(2) 12"x 36"	(2) 12"x 36"		4	12.00
			WRONG WAY	30"x 42"	30"x 42"		2	17.50
			KEEP RIGHT					
63	6	46 S.B.	STOP	36"	36"		2	18.00
			YIELD					
			DO NOT ENTER	30"	30"		2	12.50
			ONE WAY	(2) 12"x 36"	(2) 12"x 36"		4	12.00
			WRONG WAY	30"x 42"	30"x 42"		2	17.50
			KEEP RIGHT					
SUBTOTAL:							533.50	

NOTE: RED VERTICAL STRIPS SHALL BE PLACED ON ALL WRONG-WAY & DO NOT ENTER SIGN POSTS.

DATE REVISED	DATE FILED	DATE REVISED	DATE FILED	FED. DIST. NO.	STATE	FED. PROJ. NO.	SHEET NO.	TOTAL SHEETS
				6	ARK.		49	61
				JOB NO.	012260			

2 QUANTITIES



DISTRICT 10  
CRAIGHEAD COUNTY

ROUTE	SECT.	LOG MILE (EXIT NO.) DIRECTION	SIGNS	LOCATION AND SIZE			TOTAL SIGNS	
				LEFT	RIGHT	FAR RIGHT	NO.	SQ. FT.
63	6	47 N.B.	STOP	36"	36"		2	18.00
			YIELD			48"	1	7.00
			DO NOT ENTER	30"	30"	30"	3	18.75
			ONE WAY	(2) 12"x 36"	(2) 12"x 36"		4	12.00
			WRONG WAY	30"x 42"	30"x 42"		2	17.50
			KEEP RIGHT					
63	6	47 S.B.	STOP	36"	36"		2	18.00
			YIELD			48"	1	7.00
			DO NOT ENTER	30"	30"	30"	3	18.75
			ONE WAY	(2) 12"x 36"	(2) 12"x 36"		4	12.00
			WRONG WAY	30"x 42"	30"x 42"		2	17.50
			KEEP RIGHT					
63	6	49 N.B.	STOP	48"	48"		2	32.00
			YIELD			48"	1	7.00
			DO NOT ENTER	36"	36"	30"	2/1	24.25
			ONE WAY	(2) 18"x 54"	(2) 18"x 54"		4	27.00
			WRONG WAY	30"x 42"	30"x 42"		2	17.50
			KEEP RIGHT					
63	6	49 S.B.	STOP			48"	1	7.00
			YIELD		36"	30"	1/1	15.25
			DO NOT ENTER					
			ONE WAY		(2) 18"x 54"		2	13.50
			WRONG WAY	30"x 42"	30"x 42"		2	17.50
			KEEP RIGHT	24"x 30"			1	5.00
67	16	102 N.B.	STOP	36"	36"		2	18.00
			YIELD			48"	1	7.00
			DO NOT ENTER	30"	30"	30"	3	18.75
			ONE WAY	(2) 12"x 36"	(2) 12"x 36"		4	12.00
			WRONG WAY	30"x 42"	30"x 42"		2	17.50
			KEEP RIGHT					
67	16	102 S.B.	STOP	36"	36"		2	18.00
			YIELD			48"	1	7.00
			DO NOT ENTER	36"	36"	30"	2/1	24.25
			ONE WAY	(2) 12"x 36"	(2) 12"x 36"		4	12.00
			WRONG WAY	30"x 42"	30"x 42"		2	17.50
			KEEP RIGHT					
<b>SUBTOTAL:</b>							464.50	
<b>TOTAL CRAIGHEAD COUNTY:</b>							2008.50	

DISTRICT 10  
LAWRENCE COUNTY

ROUTE	SECT.	LOG MILE (EXIT NO.) DIRECTION	SIGNS	LOCATION AND SIZE			TOTAL SIGNS	
				LEFT	RIGHT	FAR RIGHT	NO.	SQ. FT.
67	17	111 N.B.	STOP	36"	36"		2	18.00
			YIELD			48"	1	7.00
			DO NOT ENTER	36"	36"	36"	3	27.00
			ONE WAY	(2) 12"x 36"	(2) 12"x 36"		4	12.00
			WRONG WAY	30"x 42"	30"x 42"		2	17.50
			KEEP RIGHT					
67	17	111 N.B.	STOP	36"	36"		2	18.00
			YIELD			48"	1	7.00
			DO NOT ENTER	36"	36"	36"	3	27.00
			ONE WAY	(2) 12"x 36"	(2) 12"x 36"		4	12.00
			WRONG WAY	30"x 42"	30"x 42"		2	17.50
			KEEP RIGHT					
67	17	121 N.B.	STOP	36"	36"		2	18.00
			YIELD					
			DO NOT ENTER	36"	36"	36"	3	27.00
			ONE WAY	(2) 12"x 36"	(2) 12"x 36"		4	12.00
			WRONG WAY	30"x 42"	30"x 42"		2	17.50
			KEEP RIGHT					
67	17	HWY. 412 INT. N.B.	STOP	48"	48"		2	32.00
			YIELD					
			DO NOT ENTER	36"	36"		2	18.00
			ONE WAY	(2) 18"x 54"	(2) 18"x 54"		4	27.00
			WRONG WAY	30"x 42"	30"x 42"		2	17.50
			KEEP RIGHT					
67	17	HWY. 412 INT. S.B.	STOP	48"	48"		2	32.00
			YIELD					
			DO NOT ENTER	36"	36"		2	18.00
			ONE WAY	(2) 18"x 54"	(2) 18"x 54"		4	27.00
			WRONG WAY	30"x 42"	30"x 42"		2	17.50
			KEEP RIGHT					
<b>TOTAL LAWRENCE COUNTY:</b>							426.50	

DISTRICT 10  
MISSISSIPPI COUNTY

ROUTE	SECT.	LOG MILE (EXIT NO.) DIRECTION	SIGNS	LOCATION AND SIZE			TOTAL SIGNS	
				LEFT	RIGHT	FAR RIGHT	NO.	SQ. FT.
55	12	34 N.B.	STOP		36"		1	9.00
			YIELD	* 48"	* 48"	48"	3	21.00
			DO NOT ENTER	(2) 36"	(2) 36"		4	36.00
			ONE WAY	(2) 12"x 36"	(2) 12"x 36"		4	12.00
			WRONG WAY	30"x 42"	30"x 42"		2	17.50
			KEEP RIGHT	24"x 30"			1	5.00
55	12	34 S.B.	STOP		36"		1	9.00
			YIELD	* 48"	* 48"		2	14.00
			DO NOT ENTER	(2) 36"	(2) 36"		4	36.00
			ONE WAY	(2) 12"x 36"	(2) 12"x 36"		4	12.00
			WRONG WAY	30"x 42"	30"x 42"		2	17.50
			KEEP RIGHT	24"x 30"			1	5.00
55	12	36 N.B.	STOP	36"	36"		3	27.00
			YIELD			48"	2	14.00
			DO NOT ENTER	30"	30"	30"	4	25.00
			ONE WAY	(2) 12"x 36"	(2) 12"x 36"		5	15.00
			WRONG WAY	30"x 42"	30"x 42"		2	17.50
			KEEP RIGHT					
55	12	36 S.B.	STOP		36"		1	9.00
			YIELD	* 48"	* 48"		2	14.00
			DO NOT ENTER	(2) 36"	(2) 36"		4	36.00
			ONE WAY	(2) 12"x 36"	(2) 12"x 36"		4	12.00
			WRONG WAY	30"x 42"	30"x 42"		2	17.50
			KEEP RIGHT	24"x 30"			1	5.00
55	12	41 N.B.	STOP	36"	36"		2	18.00
			YIELD			48"	1	7.00
			DO NOT ENTER	30"	30"	30"	3	18.75
			ONE WAY	(2) 12"x 36"	(2) 12"x 36"		4	12.00
			WRONG WAY	30"x 42"	30"x 42"		2	17.50
			KEEP RIGHT					
55	12	41 S.B.	STOP	36"	36"		2	18.00
			YIELD			48"	1	7.00
			DO NOT ENTER	30"	30"	30"	3	18.75
			ONE WAY	(2) 12"x 36"	(2) 12"x 36"		4	12.00
			WRONG WAY	30"x 42"	30"x 42"		2	17.50
			KEEP RIGHT					
<b>SUBTOTAL:</b>							532.50	

\* ON INTERSECTING ROADWAY

NOTE: RED VERTICAL STRIPS SHALL BE PLACED ON ALL WRONG-WAY & DO NOT ENTER SIGN POSTS.

DATE REVISED	DATE FILED	DATE REVISED	DATE FILED	FED. RD. DIST. NO.	STATE	FED. AID PROJ. NO.	SHEET NO.	TOTAL SHEETS	
				6	ARK.				
JOB NO.							012260	50	61

2 QUANTITIES



DISTRICT 10  
MISSISSIPPI COUNTY

ROUTE	SECT.	LOG MILE (EXIT NO.) DIRECTION	SIGNS	LOCATION AND SIZE			TOTAL SIGNS	
				LEFT	RIGHT	FAR RIGHT	NO.	SQ. FT.
55	12	44 N.B.	STOP	36"	36"		2	18.00
			YIELD			48"	1	7.00
			DO NOT ENTER	30"	30"	30"	3	18.75
			ONE WAY	(2) 12"x 36"	(2) 12"x 36"		4	12.00
			WRONG WAY	30"x 42"	30"x 42"		2	17.50
			KEEP RIGHT					
55	12	44 S.B.	STOP	36"	36"		2	18.00
			YIELD			48"	1	7.00
			DO NOT ENTER	30"	30"	30"	3	18.75
			ONE WAY	(2) 12"x 36"	(2) 12"x 36"		4	12.00
			WRONG WAY	30"x 42"	30"x 42"		2	17.50
			KEEP RIGHT					
55	12	48 N.B. (SLIP RAMP)	STOP				2	14.00
			YIELD	* 48"	* 48"		2	14.00
			DO NOT ENTER	48"	48"		2	32.00
			ONE WAY					
			WRONG WAY	30"x 42"	30"x 42"		2	17.50
			KEEP RIGHT					
55	12	48 S.B.	STOP	36"	36"		2	18.00
			YIELD			48"	1	7.00
			DO NOT ENTER	30"	30"	30"	3	18.75
			ONE WAY	(2) 12"x 36"	(2) 12"x 36"		4	12.00
			WRONG WAY	30"x 42"	30"x 42"		2	17.50
			KEEP RIGHT					
55	12	53 N.B.	STOP	36"	36"		2	18.00
			YIELD			48"	1	7.00
			DO NOT ENTER	30"	30"	30"	3	18.75
			ONE WAY	(2) 12"x 36"	(2) 12"x 36"		4	12.00
			WRONG WAY	30"x 42"	30"x 42"		2	17.50
			KEEP RIGHT					
55	12	53 S.B.	STOP	36"	36"		2	18.00
			YIELD			48"	1	7.00
			DO NOT ENTER	30"	30"	30"	3	18.75
			ONE WAY	(2) 12"x 36"	(2) 12"x 36"		4	12.00
			WRONG WAY	30"x 42"	30"x 42"		2	17.50
			KEEP RIGHT					
<b>SUBTOTAL:</b>							<b>429.75</b>	

\* ON INTERSECTING ROADWAY  
ON ALL SLIP RAMPS TO TWO-WAY FRONTAGE ROADS, (2) 48" W6-3  
SIGNS ARE REQUIRED ON THE FRONTAGE ROAD JUST BEYOND THE RAMP.

DISTRICT 10  
MISSISSIPPI COUNTY

ROUTE	SECT.	LOG MILE (EXIT NO.) DIRECTION	SIGNS	LOCATION AND SIZE			TOTAL SIGNS	
				LEFT	RIGHT	FAR RIGHT	NO.	SQ. FT.
55	12	57 N.B.	STOP	36"	36"		2	18.00
			YIELD			48"	1	7.00
			DO NOT ENTER	30"	30"	30"	3	18.75
			ONE WAY	(2) 12"x 36"	(2) 12"x 36"		4	12.00
			WRONG WAY	30"x 42"	30"x 42"		2	17.50
			KEEP RIGHT					
55	12	57 S.B.	STOP		36"		1	9.00
			YIELD	* 48"	* 48"		2	14.00
			DO NOT ENTER	(2) 36"	(2) 36"		4	36.00
			ONE WAY	(2) 12"x 36"	(2) 12"x 36"		4	12.00
			WRONG WAY	30"x 42"	30"x 42"		2	17.50
			KEEP RIGHT	24"x 30"			1	5.00
55	12	63 N.B.	STOP	48"	48"		2	32.00
			YIELD			48"	1	7.00
			DO NOT ENTER	36"	36"	30"	2/1	24.25
			ONE WAY	(2) 18"x 54"	(2) 18"x 54"		4	27.00
			WRONG WAY	30"x 42"	30"x 42"		2	17.50
			KEEP RIGHT					
55	12	63 S.B.	STOP	48"	48"		2	32.00
			YIELD			48"	1	7.00
			DO NOT ENTER	36"	36"	30"	2/1	24.25
			ONE WAY	(2) 18"x 54"	(2) 18"x 54"		4	27.00
			WRONG WAY	30"x 42"	30"x 42"		2	17.50
			KEEP RIGHT					
55	12	67 N.B. (SLIP RAMP)	STOP				1	7.00
			YIELD	* 48"			2	32.00
			DO NOT ENTER	48"	48"			
			ONE WAY					
			WRONG WAY	30"x 42"	30"x 42"		2	17.50
			KEEP RIGHT					
55	12	67 S.B. (SLIP RAMP)	STOP				2	14.00
			YIELD	* 48"	* 48"		2	32.00
			DO NOT ENTER	48"	48"			
			ONE WAY					
			WRONG WAY	30"x 42"	30"x 42"		2	17.50
			KEEP RIGHT					
<b>SUBTOTAL:</b>							<b>502.25</b>	

\* ON INTERSECTING ROADWAY  
ON ALL SLIP RAMPS TO TWO-WAY FRONTAGE ROADS, (2) 48" W6-3  
SIGNS ARE REQUIRED ON THE FRONTAGE ROAD JUST BEYOND THE RAMP.

DISTRICT 10  
MISSISSIPPI COUNTY

ROUTE	SECT.	LOG MILE (EXIT NO.) DIRECTION	SIGNS	LOCATION AND SIZE			TOTAL SIGNS	
				LEFT	RIGHT	FAR RIGHT	NO.	SQ. FT.
55	12	71 N.B. (SLIP RAMP)	STOP					
			YIELD	* 48"	* 48"		2	14.00
			DO NOT ENTER	48"	48"		2	32.00
			ONE WAY					
			WRONG WAY	30"x 42"	30"x 42"		2	17.50
			KEEP RIGHT					
55	12	71 S.B. (SLIP RAMP)	STOP					
			YIELD	* 48"	* 48"		2	14.00
			DO NOT ENTER	48"	48"		2	32.00
			ONE WAY					
			WRONG WAY	30"x 42"	30"x 42"		2	17.50
			KEEP RIGHT					
55	12	72 N.B. (SLIP RAMP)	STOP					
			YIELD	* 48"	* 48"		2	14.00
			DO NOT ENTER	48"	48"		2	32.00
			ONE WAY					
			WRONG WAY	30"x 42"	30"x 42"		2	17.50
			KEEP RIGHT					
<b>SUBTOTAL:</b>							<b>190.50</b>	
<b>TOTAL MISSISSIPPI COUNTY:</b>							<b>1655.00</b>	
<b>TOTAL DISTRICT 10:</b>							<b>5149.50</b>	

\* ON INTERSECTING ROADWAY  
ON ALL SLIP RAMPS TO TWO-WAY FRONTAGE ROADS, (2) 48" W6-3  
SIGNS ARE REQUIRED ON THE FRONTAGE ROAD JUST BEYOND THE RAMP.

NOTE: RED VERTICAL STRIPS SHALL BE PLACED ON ALL WRONG-WAY & DO NOT ENTER SIGN POSTS.

STOP LINES, WRONG-WAY ARROWS, AND RAMP DELINEATORS

DATE REVISED	DATE FILMED	DATE REVISED	DATE FILMED	FED. RD. DIST. NO.	STATE	FED. AID PROJ. NO.	SHEET NO.	TOTAL SHEETS
12/13/16				6	ARK.			
						JOB NO. 012260	51	61

(2) QUANTITIES

DISTRICT	COUNTY	ROUTE	MAIN LANE SECTION	RAMP SECTION	EXIT NUMBER	CROSS ROAD	STOP LINES	YIELD LINES	THERMO. WRONG-WAY PAVEMENT ARROWS	DELINEATOR (TYPE 2) YELLOW	DELINEATOR (TYPE 2) WHITE	TYPE OF RAMP
							LIN. FT.	LIN. FT.	EACH	EACH	EACH	
10	CRAIGHEAD	67	16	473	102	226	17	15	1	32	58	TYPICAL DIAMOND
10	CRAIGHEAD	67	16	478	102	226	17	17	1	32	58	MODIFIED DIAMOND
10	CRAIGHEAD	555	3	186	35	463	16	17	1	11	17	TYPICAL DIAMOND
10	CRAIGHEAD	555	3	191	35	463	18	15	1	24	49	LOOP
10	CRAIGHEAD	555	3	195	36	631	18	15	1	20	22	MODIFIED DIAMOND
10	CRAIGHEAD	555	3	198	36	631	18	20	1	15	18	TYPICAL DIAMOND
10	CRAIGHEAD	555	3	204	39	185	15	12	1	20	23	MODIFIED DIAMOND
10	CRAIGHEAD	555	3	207	39	185	16	12	1	15	18	TYPICAL DIAMOND
10	CRAIGHEAD	555	3	216	40	463	15	15	1	22	43	LOOP
10	CRAIGHEAD	555	3	218	40	463	15	16	1	10	21	MODIFIED DIAMOND
10	CRAIGHEAD	555	3	234	42	49/1	27	15	1	11	13	MODIFIED DIAMOND
10	CRAIGHEAD	555	3	241	42	49/1	20	16	1	12	13	MODIFIED DIAMOND
10	CRAIGHEAD	555	3	245	42	CARAWAY RD.	25	16	1	10	11	MODIFIED DIAMOND
10	CRAIGHEAD	555	3	251	42	CARAWAY RD.	16	16	1	14	14	MODIFIED DIAMOND
10	CRAIGHEAD	555	3	256	44	1B	22	16	1	11	13	TYPICAL DIAMOND
10	CRAIGHEAD	555	3	261	44	1B	15	22	1	11	14	TYPICAL DIAMOND
10	CRAIGHEAD	555	3	266	45	49/18	15	22	1	18	30	TYPICAL DIAMOND
10	CRAIGHEAD	63	6	271	45	49/18	16	22	1	10	13	TYPICAL DIAMOND
10	CRAIGHEAD	63	6	275	46	226	22		1	4	7	TYPICAL DIAMOND
10	CRAIGHEAD	63	6	277	46	226	22		1	4	6	TYPICAL DIAMOND
10	CRAIGHEAD	63	6	286	47	WASHINGTON AVE.	26	15	1	11	13	TYPICAL DIAMOND
10	CRAIGHEAD	63	6	289	47	WASHINGTON AVE.	29	15	1	15	17	TYPICAL DIAMOND
10	CRAIGHEAD	63	6	296	49	91	24	16	1	10	11	TYPICAL DIAMOND
10	CRAIGHEAD	63	6	302	49	91	22	16	1	24	56	LOOP
<b>SUBTOTALS CRAIGHEAD COUNTY:</b>							<b>466</b>	<b>361</b>	<b>24</b>	<b>366</b>	<b>558</b>	
10	LAWRENCE	67	17	485	121B	63			1	37	46	LOOP
10	LAWRENCE	67	17	489	121A	63			1	38	50	TYPICAL DIAMOND
10	LAWRENCE	67	17	491	N/A	412	58		1	41	41	MODIFIED DIAMOND
10	LAWRENCE	67	17	493	N/A	412	60		1	64	66	TYPICAL DIAMOND
10	LAWRENCE	67	17	N/A	111	230	21	17	1	24	25	TYPICAL DIAMOND
10	LAWRENCE	67	17	N/A	111	230	21	17	1	25	26	TYPICAL DIAMOND
10	LAWRENCE	67	17	N/A	121	63	20		1	45	52	MODIFIED DIAMOND
<b>SUBTOTALS LAWRENCE COUNTY:</b>							<b>180</b>	<b>34</b>	<b>7</b>	<b>274</b>	<b>306</b>	
10	MISSISSIPPI	55	12	215	34	118	22	27	1	10	8	MODIFIED DIAMOND
10	MISSISSIPPI	55	12	219	34	118	26	13	1	7	8	MODIFIED DIAMOND
10	MISSISSIPPI	55	12	226	36	181	16	17	1	20	17	MODIFIED DIAMOND
10	MISSISSIPPI	55	12	231	36	181	18	16	1	9	8	MODIFIED DIAMOND
10	MISSISSIPPI	55	12	236	41	14	17	16	1	21	18	MODIFIED DIAMOND
10	MISSISSIPPI	55	12	241	41	14	16	16	1	21	18	MODIFIED DIAMOND
10	MISSISSIPPI	55	12	245	44	181	23	17	1	23	20	TYPICAL DIAMOND
10	MISSISSIPPI	55	12	249	44	181	28	20	1	24	21	TYPICAL DIAMOND
10	MISSISSIPPI	55	12	258	48	140			1	7	4	SLIP
10	MISSISSIPPI	55	12	265	48	140	23	16	1	21	18	TYPICAL DIAMOND
10	MISSISSIPPI	55	12	272	53	158	15	16	1	20	17	MODIFIED DIAMOND
10	MISSISSIPPI	55	12	276	53	158	14	16	1	20	17	MODIFIED DIAMOND
10	MISSISSIPPI	55	12	282	58	148	16	16	1	21	18	MODIFIED DIAMOND
10	MISSISSIPPI	55	12	286	58	148	26	15	1	9	7	MODIFIED DIAMOND
10	MISSISSIPPI	55	12	293	63	61	37	19	1	17	14	TYPICAL DIAMOND
10	MISSISSIPPI	55	12	298	63	61	15	19	1	17	14	TYPICAL DIAMOND
10	MISSISSIPPI	55	12	304	67	18			1	5	7	SLIP
10	MISSISSIPPI	55	12	324	WELCOME CENTER	WELCOME CENTER			1	13	10	TYPICAL DIAMOND
10	MISSISSIPPI	55	12	326	72	150			1	6	6	SLIP
10	MISSISSIPPI	55	12	331	71	150			1	6	6	SLIP
10	MISSISSIPPI	55	12	336	72	N/A			1	6	6	SLIP
10	MISSISSIPPI	55	12	338	WEIGH STATION	WEIGH STATION			1	9	7	TYPICAL DIAMOND
10	MISSISSIPPI	55	12	343	67	18			1	5	6	SLIP
10	MISSISSIPPI	55	12	358	TRUCK PARKING	TRUCK PARKING			1	12	9	TYPICAL DIAMOND
10	MISSISSIPPI	55	12	361	TRUCK PARKING	TRUCK PARKING			1	12	9	TYPICAL DIAMOND
<b>SUBTOTALS MISSISSIPPI COUNTY:</b>							<b>312</b>	<b>259</b>	<b>25</b>	<b>341</b>	<b>293</b>	
10	POINSETT	555	2	126	7	135	22	15	1	17	19	TYPICAL DIAMOND
10	POINSETT	555	2	128	7	135	20	17	1	16	19	TYPICAL DIAMOND
10	POINSETT	555	2	131	8	118	18	15	1	13	15	TYPICAL DIAMOND
10	POINSETT	555	2	134	8	118	16	15	1	16	39	LOOP
10	POINSETT	555	2	141	13	63B	15	18	1	18	47	LOOP
10	POINSETT	555	2	145	13	63B	20	20	1	18	21	TYPICAL DIAMOND
10	POINSETT	555	2	147	14	63B	22	20	1	12	15	MODIFIED DIAMOND
10	POINSETT	555	2	151	14	63B	24		1	12	14	MODIFIED DIAMOND
10	POINSETT	555	2	155	18	14	30	16	1	10	12	TYPICAL DIAMOND
10	POINSETT	555	2	159	18	14	22	17	1	14	16	MODIFIED DIAMOND
10	POINSETT	555	2	164	24	463	24	15	1	19	21	TYPICAL DIAMOND
10	POINSETT	555	2	168	24	463	20	17	1	18	21	TYPICAL DIAMOND
10	POINSETT	555	2	175	29	69	24	17	1	13	16	TYPICAL DIAMOND
10	POINSETT	555	2	179	29	69	22	16	1	13	16	TYPICAL DIAMOND
<b>SUBTOTALS POINSETT COUNTY:</b>							<b>299</b>	<b>218</b>	<b>14</b>	<b>209</b>	<b>291</b>	
<b>TOTALS DISTRICT 10:</b>							<b>1257</b>	<b>872</b>	<b>70</b>	<b>1190</b>	<b>1448</b>	

LANE EXTENSIONS

DISTRICT	COUNTY	ROUTE	MAIN LANE SECTION	RAMP SECTION	EXIT NO	CROSS ROAD	LENGTH OF LANE EXTENSION
							LIN. FT.
10	CRAIGHEAD	555	3	188	35	463	60
10	CRAIGHEAD	555	3	191	35	463	63
10	CRAIGHEAD	555	3	216	40	463	87
10	CRAIGHEAD	555	3	221	40	463	90
10	CRAIGHEAD	555	3	253	42	CARAWAY	57
10	CRAIGHEAD	555	3	268	45	18	70
10	CRAIGHEAD	555	6	302	49	91	132
<b>TOTAL CRAIGHEAD COUNTY:</b>							<b>559</b>
10	POINSETT	555	2	134	8	118	122
10	POINSETT	555	2	141	13	63B	83
<b>TOTAL POINSETT COUNTY:</b>							<b>205</b>
<b>TOTAL DISTRICT 10:</b>							<b>764</b>

NOTE: LANE EXTENSIONS SHALL BE DASHED, 4" WIDE, YELLOW PAVEMENT MARKINGS THAT GUIDE LEFT-TURNING TRAFFIC FROM THE CROSS ROAD TO THE CORRECT RAMP AT A FREEWAY INTERCHANGE. LANE EXTENSIONS SHALL BE PAID FOR UNDER "THERMOPLASTIC PAVEMENT MARKING YELLOW (6)".

BARRIER WALL DELINEATORS

DISTRICT	COUNTY	ROUTE	SECTION	EXIT NO	CROSS ROAD	BARRIER LENGTH	NUMBER OF BARRIER WALL DELINEATORS
						LIN. FT.	EACH
10	CRAIGHEAD	555	3	35	HWY. 463	428	43
10	CRAIGHEAD	555	3	35	HWY. 463	656	66
10	CRAIGHEAD	555	3	40	HWY. 63B/HWY. 463	391	39
10	CRAIGHEAD	555	3	40	HWY. 63B/HWY. 463	852	85
10	CRAIGHEAD	555	3	42	CARAWAY RD.	440	44
10	CRAIGHEAD	555	3	45	HWY. 49/HWY. 18	210	21
10	CRAIGHEAD	63	6	49	HWY. 91	650	65
<b>SUBTOTAL CRAIGHEAD COUNTY:</b>							<b>363</b>
10	POINSETT	555	2	8	HWY. 118	371	37
10	POINSETT	555	2	13	HWY. 149	584	59
<b>SUBTOTAL POINSETT COUNTY:</b>							<b>96</b>
<b>TOTAL DISTRICT 10:</b>							<b>459</b>

LANE USE ARROWS

DISTRICT	COUNTY	ROUTE	SECTION	DIRECTION	EXIT NO.	LANE USE ARROWS	TO
						EACH	
10	MISSISSIPPI	55	12	NB	72	2	STATE LINE ROAD/N CO. RD. 761
10	MISSISSIPPI	55	12	SB	71	2	AR 150/N CO. RD. 757
10	MISSISSIPPI	55	12	NB	71	2	AR 150/N CO. RD. 761
10	MISSISSIPPI	55	12	SB	67	2	AR 18/ N CO. RD. 757
10	MISSISSIPPI	55	12	NB	67	2	AR 18/PORTER DR.
10	MISSISSIPPI	55	12	NB	48	2	AR 140/ S CO. RD. 439
<b>TOTAL DISTRICT 10:</b>						<b>12</b>	

NOTE: LANE USE ARROWS WILL BE PLACED IN A PAIR (AS SHOWN ON SHEET 6) TO SHOW THE CORRECT TRAFFIC MOVEMENT FOR VEHICLES EXITING THE FREEWAY AND VEHICLES ON THE FRONTAGE ROADS. THE CONTRACTOR SHALL PLACE THE ARROWS, ONE FOR EACH DIRECTION OF TRAVEL, ON TWO-WAY FRONTAGE ROADS DOWNSTREAM FROM A FREEWAY EXIT RAMP. SEE DETAIL ON SHEET NO. 6. LANE USE ARROWS SHALL BE PAID FOR UNDER "THERMOPLASTIC PAVEMENT MARKING (ARROWS)".

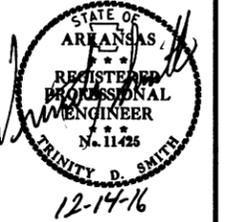

DATE REVISED	DATE FILMED	DATE REVISED	DATE FILMED	FED. AID DIST. NO.	STATE	FED. AID PROJ. NO.	SHEET NO.	TOTAL SHEETS
12/13/16				6	ARK.		52	61
				JOB NO. 012260			52	61

2 QUANTITIES

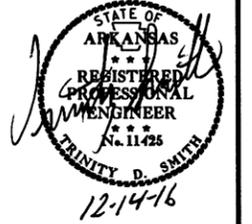

**PERMANENT PAVEMENT MARKINGS**

DESCRIPTION	DIST. 1	DIST. 2	DIST. 3	DIST. 4	DIST. 5	DIST. 6	DIST. 7	DIST. 8	DIST. 9	DIST. 10	TOTAL JOB 012260	THERMOPLASTIC PAVEMENT MARKING			
												6" YELLOW		12" WHITE	ARROWS
												LIN. FT. - EACH		YIELD LINE	EACH
* LANE EXTENSIONS	156		60	724	34	1586	65	222		764	3611	3611			
THERMOPLASTIC PAVEMENT MARKING WHITE (12")	802	643	1374	2051	1040	3027	622	963	689	1257	12468		12468		
THERMOPLASTIC PAVEMENT MARKING WHITE (YIELD LINE)	606	332	568	638	962	2680	369	969	226	872	8222			8222	
** LANE USE ARROWS	18			2		14					46				46
*** WRONG-WAY ARROW	60	24	53	79	44	190	27	52	17	70	616				616
<b>TOTALS:</b>												<b>3611</b>	<b>12468</b>	<b>8222</b>	<b>662</b>

NOTE: THIS IS A HIGH TRAFFIC VOLUME ROAD AS DEFINED IN SECTION 604.03, STANDARD SPECIFICATIONS FOR HIGHWAY CONSTRUCTION.

QUANTITIES ESTIMATED.  
SEE SECTION 104.03 OF THE STD. SPECS.

- \* LANE EXTENSIONS SHALL BE PAID FOR UNDER "THERMOPLASTIC PAVEMENT MARKING YELLOW (6)".
- \*\* LANE USE ARROWS SHALL BE PAID FOR UNDER "THERMOPLASTIC PAVEMENT MARKING (ARROWS)".
- \*\*\* THERMOPLASTIC WRONG WAY PAVEMENT ARROWS SHALL BE PAID FOR UNDER "THERMOPLASTIC PAVEMENT MARKING (ARROWS)".

**STANDARD SIGNS/ SIGN SUPPORT**

DISTRICT	STANDARD SIGNS SQ. FT.	CHANNEL POST SIGN SUPPORT		REMOVAL AND DISPOSAL OF SIGN POSTS EACH
		(TYPE U-1) EACH	(TYPE U-2) EACH	
DISTRICT 1	3173.25			
DISTRICT 2	1622.50			
DISTRICT 3	3443.50			
DISTRICT 4	5582.75			
DISTRICT 5	3531.25			
DISTRICT 6	10154.75			
DISTRICT 7	1819.00			
DISTRICT 8	3513.50			
DISTRICT 9	1763.75			
DISTRICT 10	5149.50			
* CHANNEL POST SIGN SUPPORT (TYPE U-1)		400		
* CHANNEL POST SIGN SUPPORT (TYPE U-2)			1650	
* REMOVAL AND DISPOSAL OF SIGN POSTS				1700
<b>TOTALS:</b>	<b>39753.75</b>	<b>400</b>	<b>1650</b>	<b>1700</b>

\*QUANTITY ESTIMATED.  
SEE SECTION 104.03 OF THE STD. SPECS.

**DELINEATION**

DESCRIPTION	DIST. 1	DIST. 2	DIST. 3	DIST. 4	DIST. 5	DIST. 6	DIST. 7	DIST. 8	DIST. 9	DIST. 10	TOTAL JOB 012260	BARRIER WALL DELINEATOR	DELINEATOR (TYPE 2)	REMOVAL & DISPOSAL OF DELINEATOR POST
BARRIER WALL DELINEATOR	36		41	158	120	1239	98	157		459	2308	2308		
DELINEATOR (TYPE 2) YELLOW	986	376	932	1871	1207	4274	444	853	281	1190				
DELINEATOR (TYPE 2) WHITE	1232	440	1213	3124	1207	4263	470	1117	281	1448				
DELINEATOR (TYPE 2) TOTAL	2218	816	2145	4995	2414	8537	914	1970	562	2638	27209		27209	
* REMOVAL AND DISPOSAL OF EXISTING DELINEATOR POST											7000			7000
<b>TOTALS:</b>												<b>2308</b>	<b>27209</b>	<b>7000</b>

\* QUANTITY ESTIMATED.  
SEE SECTION 104.03 OF THE STD. SPECS.

DATE REVISED	DATE FILED	DATE REVISED	DATE FILED	FED. RD. DIST. NO.	STATE	FED. AID PROJ. NO.	SHEET NO.	TOTAL SHEETS
10/24/16				6	ARK.			
12/13/16								
1/3/17								
				JOB NO.	012260		53	61

② SUMMARY OF QUANTITIES AND REVISIONS



SUMMARY OF QUANTITIES

ITEM NUMBER	ITEM	QUANTITY	UNIT
SP & 202	REMOVAL AND DISPOSAL OF DELINEATOR POST	7000	EACH
202	REMOVAL AND DISPOSAL OF SIGN POSTS	1700	EACH
601	MOBILIZATION	1.00	LUMP SUM
SP & 603	MAINTENANCE OF TRAFFIC	1.00	LUMP SUM
635	ROADWAY CONSTRUCTION CONTROL	1.00	LUMP SUM
719	THERMOPLASTIC PAVEMENT MARKING WHITE (12")	12468	LIN. FT.
719	THERMOPLASTIC PAVEMENT MARKING YELLOW (6")	3611	LIN. FT.
719	THERMOPLASTIC PAVEMENT MARKING (YIELD LINE)	8222	LIN. FT.
719	THERMOPLASTIC PAVEMENT MARKING (ARROWS)	662	EACH
SP & 726	STANDARD SIGN	39754	SQ. FT.
728	DELINEATOR (TYPE 2)	27209	EACH
729	CHANNEL POST SIGN SUPPORT (TYPE U-1)	400	EACH
729	CHANNEL POST SIGN SUPPORT (TYPE U-2)	1650	EACH
SP	BARRIER WALL DELINEATOR	2308	EACH

REVISIONS

DATE	REVISION	SHEET NUMBER
10/24/2016	ADDED NOTE 10 TO GENERAL NOTES.	2, 53
12/13/2016	REVISED QUANTITIES FOR THERMOPLASTIC PAVEMENT MARKING WHITE (12"), THERMOPLASTIC PAVEMENT MARKING (YIELD LINE), THERMOPLASTIC PAVEMENT MARKING (ARROWS), STANDARD SIGN, DELINEATOR (TYPE 2), AND BARRIER WALL DELINEATOR; REMOVED QUANTITY FOR THERMOPLASTIC PAVEMENT MARKING YELLOW (4"); ADDED QUANTITY FOR THERMOPLASTIC PAVEMENT MARKING YELLOW (6"); ADDED SHEET 5A, RAMP DELINEATOR, TO SPECIAL DETAILS; REMOVED SHEET 58, STANDARD DRAWING SHS-8 (TYPICAL DELINEATOR PLACEMENT ALONG THE INTERSTATE SYSTEM," FROM PLANS, ADDED "THIS PAGE INTENTIONALLY LEFT BLANK" SHEET TO SHEET 58	2, 5A, 10, 12, 16, 20-22, 26-27, 29, 32-38A, 40, 44-46, 51-53, 58
1/3/2017	REVISED THE CONTRACT TIME FROM 150 WORKING DAYS TO 225 WORKING DAYS.	53

r012260.dgn Quantities

12/8/16

- NOTES:
1. REFER TO THE STRIPING DETAILS FOR PAVEMENT MARKING LINE WIDTHS.
  2. THIS DRAWING SHALL BE USED IN CONJUNCTION WITH THE LATEST REVISED ADDITION OF THE "MANUAL ON UNIFORM TRAFFIC CONTROL DEVICES."
  3. RAISED PAVEMENT MARKERS SHALL BE PLACED ON AN 80 FEET SPACING UNLESS OTHERWISE SHOWN IN THE PLANS.

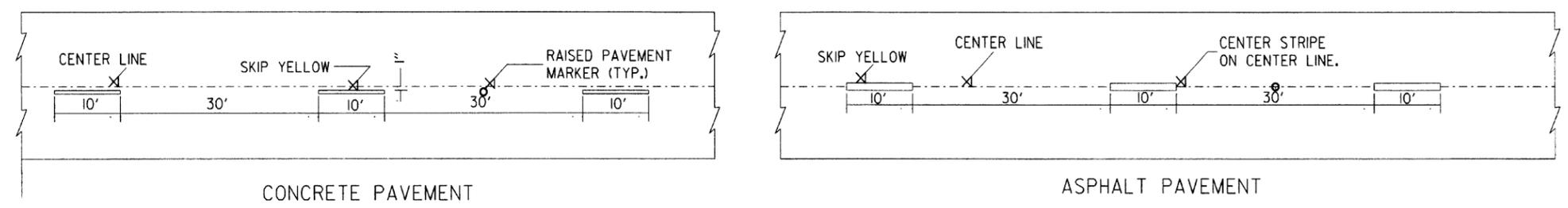

BROKEN LINE STRIPING

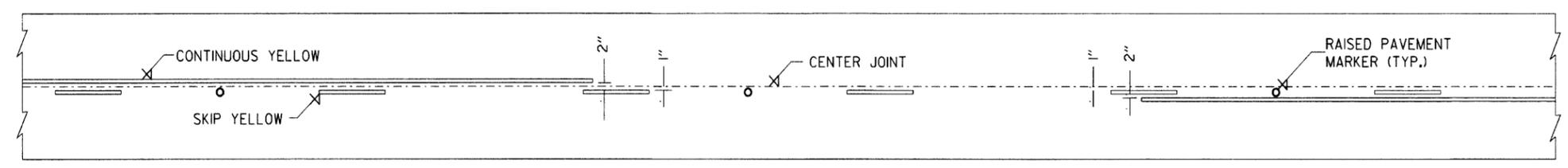

SOLID LINE STRIPING ON CONCRETE PAVEMENT

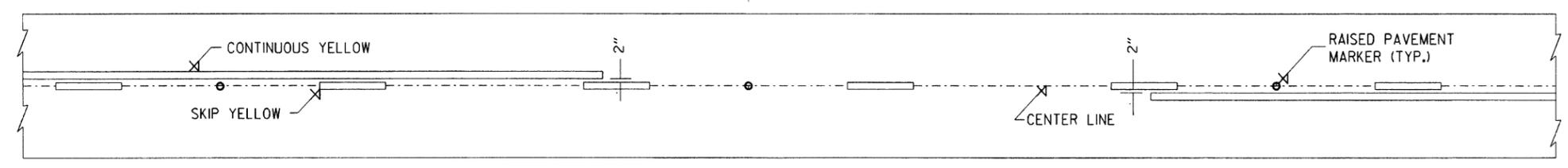

SOLID LINE STRIPING ON ASPHALT PAVEMENT

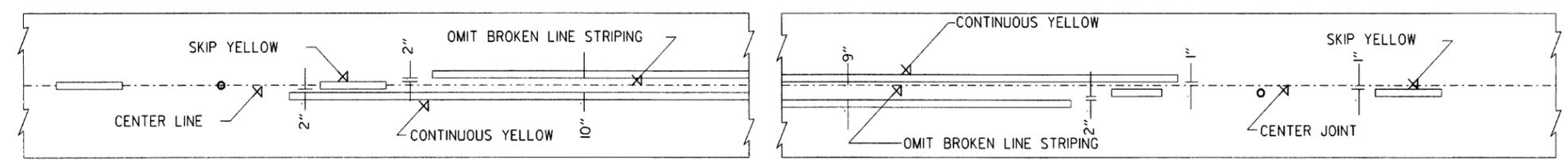

ASPHALT PAVEMENT

CONCRETE PAVEMENT

STRIPING AT ADJACENT NO PASSING LANES

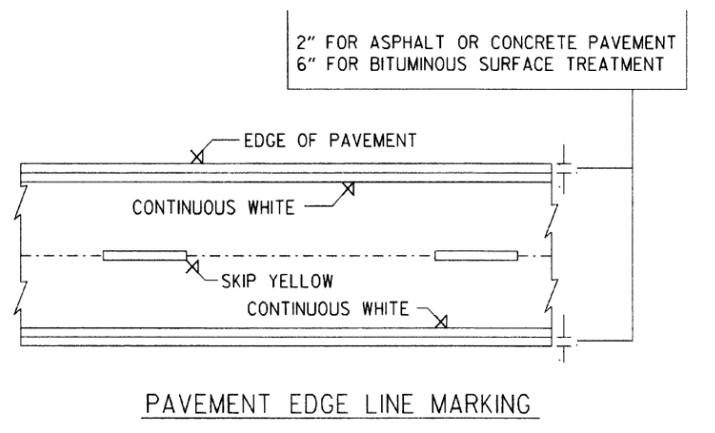

PAVEMENT EDGE LINE MARKING

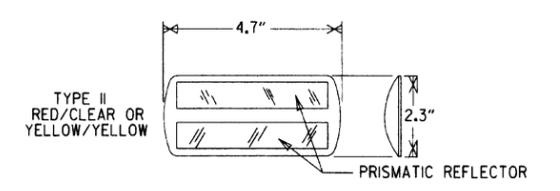

NOTE:  
THE RED LENS OF THE TYPE II R.P.M. SHALL FACE THE INCORRECT TRAFFIC MOVEMENT.



DETAIL OF STANDARD RAISED PAVEMENT MARKERS

NOTE:  
DIMENSIONS SHOWN FOR RAISED PAVEMENT MARKERS ARE TYPICAL. THE CONTRACTOR MAY SUBSTITUTE SIMILAR MARKERS WITH THE APPROVAL OF THE ENGINEER. REQUESTING APPROVAL FOR SIMILAR MARKERS MAY BE MADE BY REFERRING TO THE AHTD QUALIFIED PRODUCTS LIST.

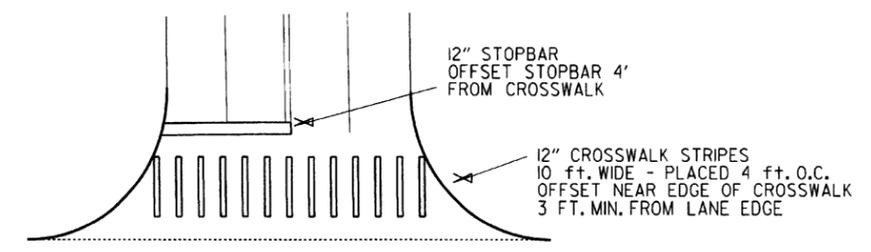

CROSSWALK AND STOPBAR DETAILS

DATE	REVISION	FILMED
5-12-16	REVISED LINE WIDTHS, SPACING, & NOTES	
9-12-13	REVISED DETAIL OF STANDARD RAISED PAVEMENT MARKERS	
11-17-10	REVISED GENERAL NOTES & REMOVED PLOWABLE PVMT MRKRS	
11-18-04	REVISED NOTE 2 & GENERAL NOTES	
8-22-02	ADDED CROSSWALK & STOPBAR DTLS.	
7-02-98	ADDED DETAILS OF STD. RAISED PAV'T. MARKERS	
4-26-96	REV. NOTES 3&4; ADDED R.P.M.	
9-30-80	DRAWN	1-9-30-80
		FILMED

ARKANSAS STATE HIGHWAY COMMISSION

**PAVEMENT MARKING DETAILS**

STANDARD DRAWING PM-1

ENTRANCE RAMP  
 8" WHITE = 228 LIN. FT.  
 RAISED PAVEMENT MARKERS TYPE II (WHITE/RED) = 38 EACH

EXIT RAMP  
 6" WHITE = 280 LIN. FT.  
 8" WHITE = 655 LIN. FT.  
 RAISED PAVEMENT MARKERS TYPE II (WHITE/RED) = 38 EACH  
 RAISED PAVEMENT MARKERS TYPE II (WHITE/RED) = 48 EACH  
 RAISED PAVEMENT MARKERS TYPE II (WHITE/RED) = 38 EACH

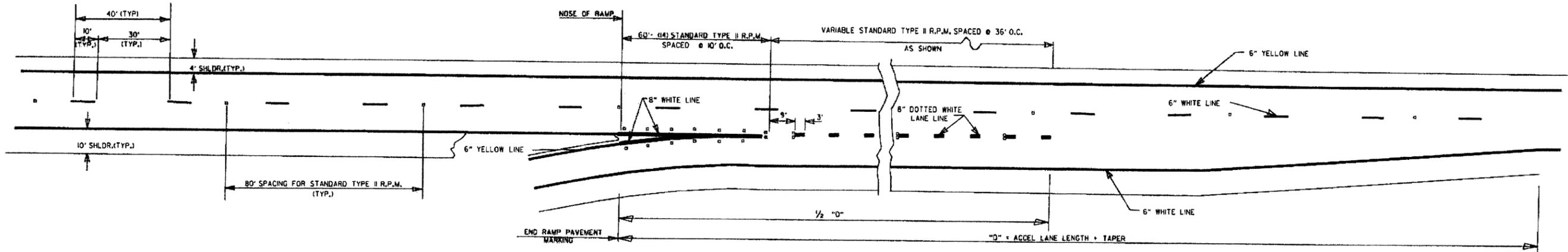

ENTRANCE RAMPS

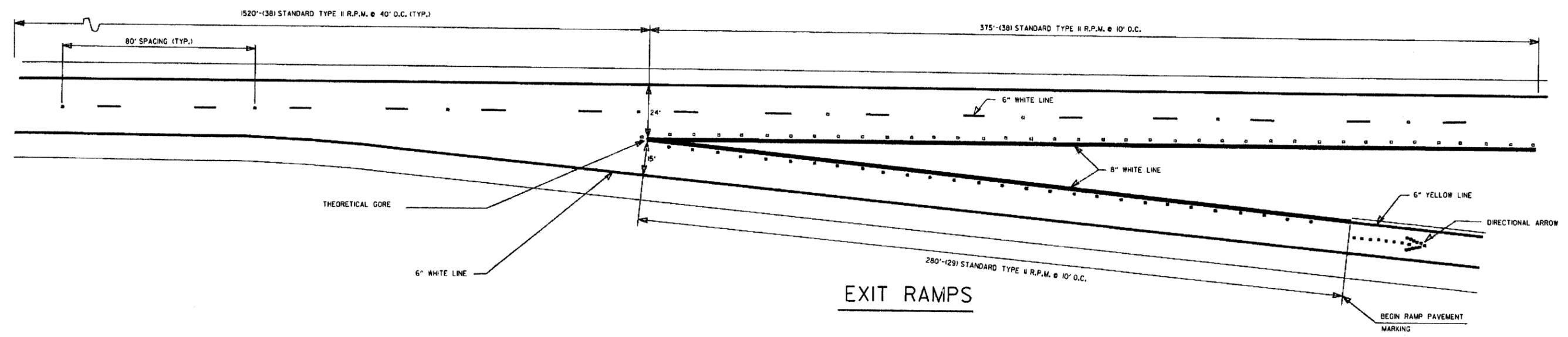

EXIT RAMPS

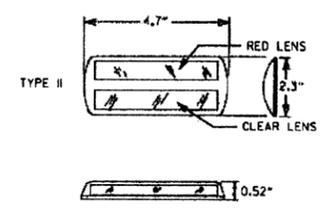

DETAIL OF STANDARD RAISED PAVEMENT MARKERS

NOTE:  
THE RED LENS OF THE TYPE II R.P.M. SHALL FACE THE INCORRECT TRAFFIC MOVEMENT.

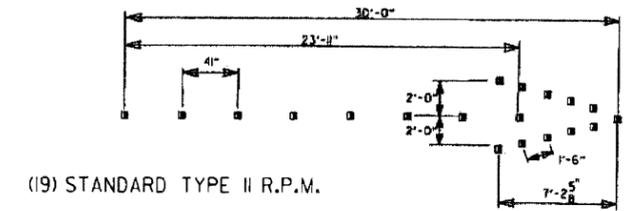

(19) STANDARD TYPE II R.P.M.

DIRECTIONAL ARROWS

GENERAL NOTES:  
THIS DRAWING SHOULD BE CONSIDERED AS TYPICAL ONLY AND THE FINAL LOCATION OF THE STRIPING AND PAVEMENT MARKERS SHALL BE DETERMINED BY THE ENGINEER.

THIS DRAWING SHOULD BE USED IN CONJUNCTION WITH THE "MANUAL ON UNIFORM TRAFFIC CONTROL DEVICES", LATEST REVISION.

NOTE:  
DIMENSIONS SHOWN FOR RAISED PAVEMENT MARKERS ARE TYPICAL. THE CONTRACTOR MAY SUBSTITUTE SIMILAR MARKERS WITH THE APPROVAL OF THE ENGINEER. REQUESTING APPROVAL FOR SIMILAR MARKERS MAY BE MADE BY REFERRING TO THE AHTD QUALIFIED PRODUCTS LIST.

DATE	REVISION	FILMED
12-8-16	REVISED RAISED PAV'T MARKERS FOR 80' SPACING; REVISED WIDTH OF STRIPING	
9-12-13	REVISED DETAIL OF STANDARD RAISED PAVEMENT MARKERS	
7-26-12	REVISED RPM NOTATION	
12-15-11	REVISED RPMs ACCORDING TO LATEST POLICY	
11-17-10	REMOVED PLOWABLE PAVEMENT MARKERS	
6-3-10	REVISED PER 2009 MUTCD	
11-18-04	REVISED NOTES	
8-22-02	ADDED & REVISED NOTES; RE-ENTRANCE & EXIT RAMPS	
5-18-00	REMOVED HASHMARKS	
7-02-98	CHANGED TYPES TO ROMAN NUMERALS	
4-26-96	ADDED DIMENSIONS & QUANTITIES; REVISED LANE WIDTH ON EXIT RAMP	
2-2-95	PLACED IN USE	2-2-95

ARKANSAS STATE HIGHWAY COMMISSION  
 PERMANENT PAVEMENT MARKING  
 ON ACCESS CONTROLLED ROADWAYS  
 STANDARD DRAWING PM-2

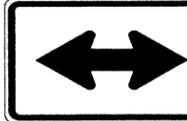
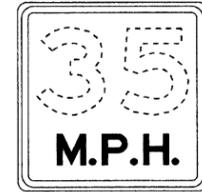
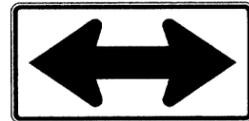
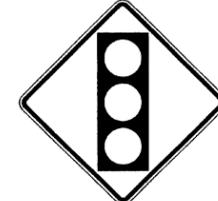
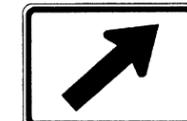
 RI-1 30"x30"	 WI-3 30"x30" (LT. OR RT.)	 WI-8 18"x24"	 W2-5 30"x30"	 W3-1 36"x36"	 W5-1 36"x36"	 M6-3 21"x15"
 RI-2 36"x36"x36"	 WI-4 30"x30" (LT. OR RT.)	 W2-1 30"x30"	 SI-1 36"x36"	 W3-2 36"x36"	 MI-6 24"x24" NOTE: REFLECTORIZED YELLOW LEGEND (COUNTY NAME, ROUTE LETTER & NUMBER) & BORDER ON A BLUE BACKGROUND.	 M6-4 21"x15"
 R2-1 24"x30"	 WI-5 30"x30" (LT. OR RT.)	 W2-2 30"x30"	 W5-2 36"x36"	 W8-3 36"x36"	 RI-3P 18"x6"	 M6-5 21"x15"
 WI-1 30"x30" (LT. OR RT.)	 WI-6 48"x24"	 W2-3 30"x30" (LT. OR RT.)	 W5-3 36"x36"	 W13-1P 18"x18"	 M6-1 21"x15"	 M6-6 21"x15"
 WI-2 30"x30" (LT. OR RT.)	 WI-7 48"x24"	 W2-4 30"x30"	 W10-1 36" DIAMETER	 W3-3 36"x36"	 M6-2 21"x15"	 S4-3P 24"x8"   S4-2P 24"x10"

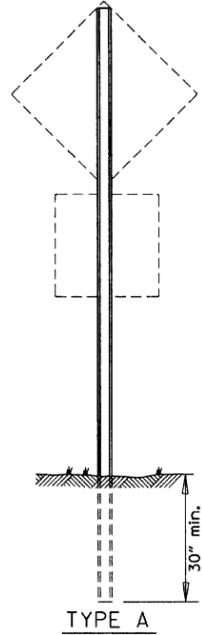
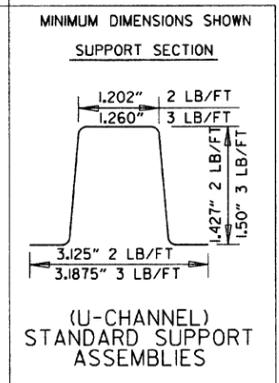

NOTE: LENGTH OF SIGN POSTS SHALL BE DETERMINED SO AS TO PROVIDE FOR MINIMUM VERTICAL CLEARANCES AS CALLED FOR IN THE SPECIFICATIONS PLUS A MINIMUM VERTICAL PENETRATION OF 30" IN THE SOIL.

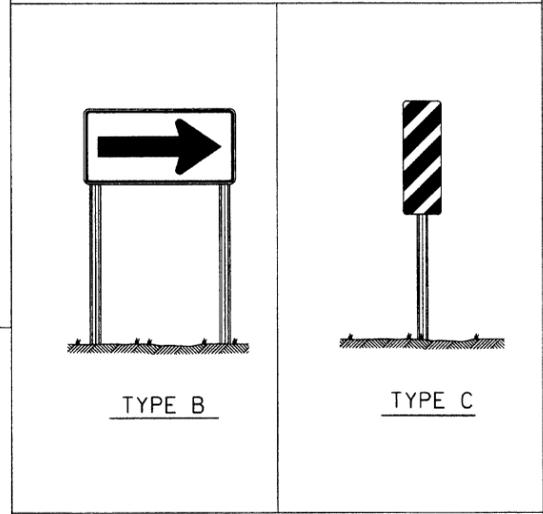

MINIMUM WEIGHT  
TYPE A & B = 3 LBS./FT.  
TYPE C = 2 LBS./FT.

STANDARD HIGHWAY SIGNS

SUPPORT ASSEMBLIES

9-12-13	DELETED JOB NO. BLOCK; REVISED RI-3 TO RI-3P	
4-17-08	REVISED SIGN DESIGNATION - W3-1A, W3-2	
4-10-03	REVISED W3-2, W8-3, OM-3; ADDED WI-8	
1-5-81	REDRAWN	960-1-15-81
9-15-78	ADDED WI-4-3	877-9-15-78
9-2-76	POST WT.	623-9-3-76
5-3-76	STEEL POST WT. FROM 2"-3"; ADDED S4-2 & S4-3	504-5-3-76
8-12-74	REV. ILL. TYPE "C" ASSEMBLY	500-8-21-74
12-21-72	ADDED M6-2,3,4,5,6	500-12-21-72
12-1-72	ISSUED	562-12-1-72
DATE	REVISION	DATE FILMED

ARKANSAS STATE HIGHWAY COMMISSION  
STANDARD HIGHWAY SIGNS  
AND SUPPORT ASSEMBLIES  
STANDARD DRAWING SHS-1

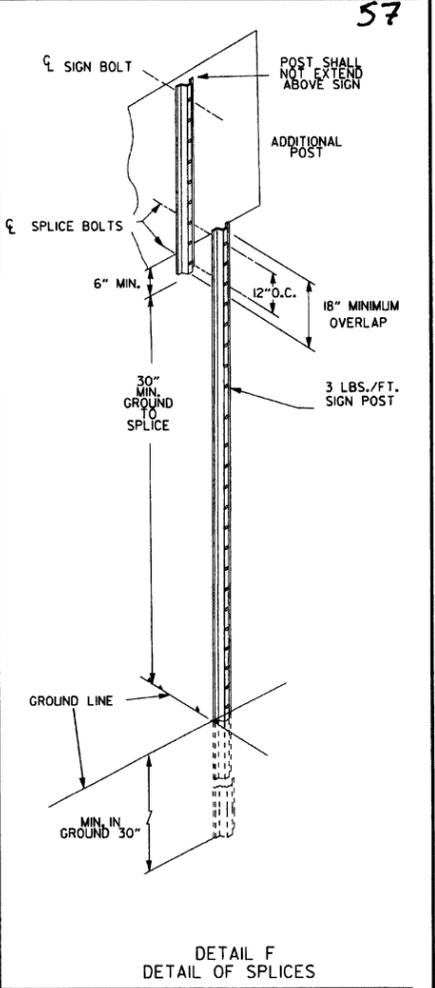
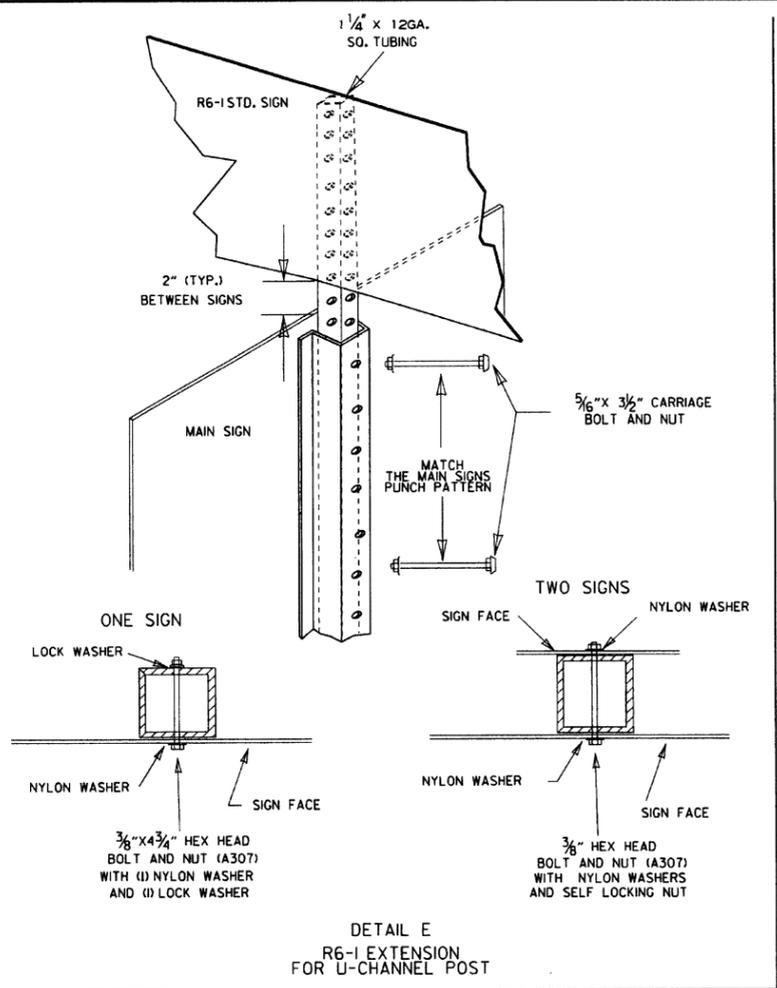
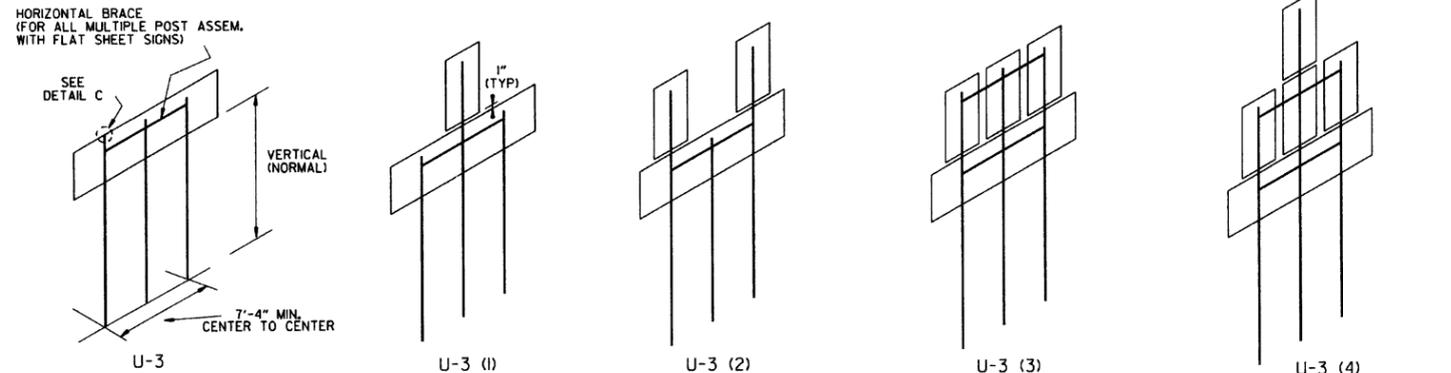
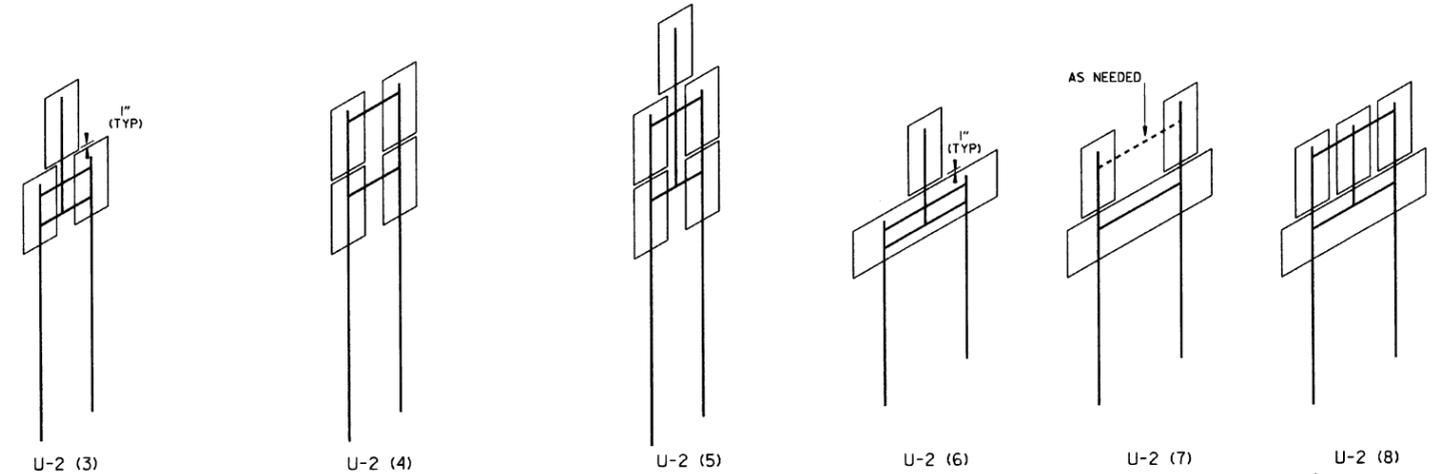
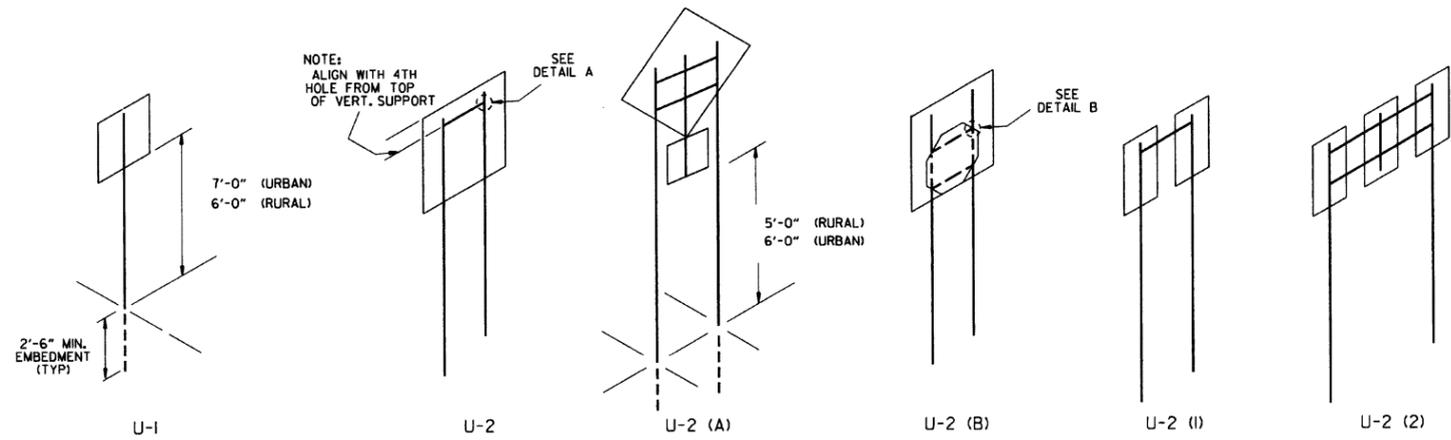

NOTES:

SIGNS AT LEAST 8' IN LENGTH MAY BE INSTALLED ON THREE 3 LB. POST. IN NO CASE SHALL THERE BE MORE THAN TWO 3 LB. POSTS WITHIN A 7' PATH.

SPLICES NECESSARY TO ATTAIN PROPER MOUNTING HEIGHT SHALL BE AS SHOWN IN DETAIL (F).

NORMAL INSTALLATIONS WILL REQUIRE 5/8" DIA. CARRIAGE BOLTS TO MOUNT SIGNS TO POST AND TO ASSEMBLE THE VARIOUS POST SUPPORTS.

ALL SIGN POSTS SHALL BE PLUMB.

THE POST FOR "TYPE U" SUPPORTS SHALL BE HOT DIP GALVANIZED.

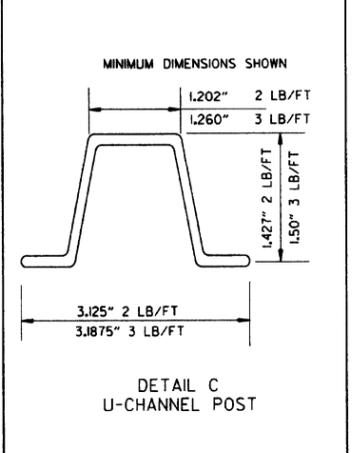
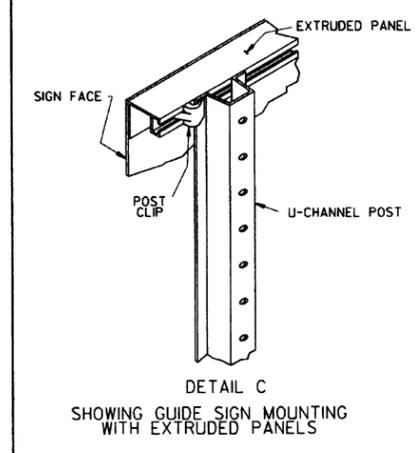
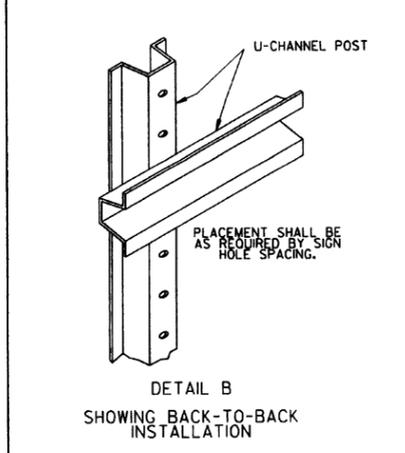
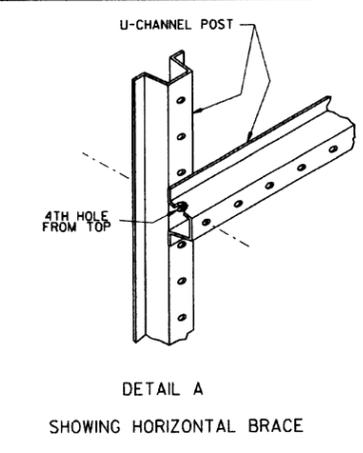
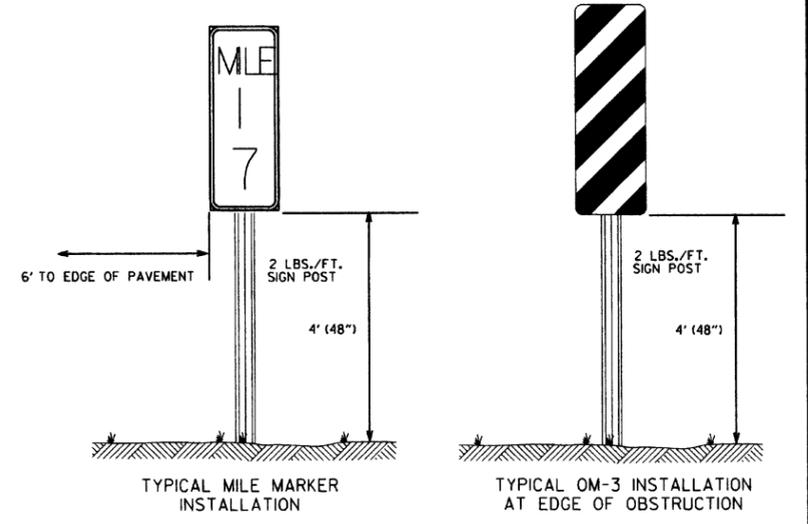

DATE	REVISION	FILMED
9-12-13	REVISED U-2(3), U-2(6), U-3(I), DETAIL D; ADDED DETAILS E & F; ADDED TYPICAL MARKERS	
10-9-03	REMOVED ROUND POST & REVISED SPACING	
10-12-95	MOVED UPPER SPLICE	
6-8-95	REVISED SPLICE DETAIL	6-8-95
2-2-95	REDRAWN	2-2-95

ARKANSAS STATE HIGHWAY COMMISSION

U-CHANNEL POST ASSEMBLIES

STANDARD DRAWING SHS-2

THIS PAGE INTENTIONALLY LEFT BLANK

ADVANCE DISTANCES  
(XXXX)

500 FT	1/2 MILE
1000 FT	3/4 MILE
1500 FT	1 MILE AHEAD

- GENERAL NOTES:
- ALL TRAFFIC CONTROL DEVICES USED ON ROAD CONSTRUCTION SHALL CONFORM TO THE MANUAL ON UNIFORM TRAFFIC CONTROL DEVICES, LATEST EDITION, AND TO THE STANDARD HIGHWAY SIGNS, LATEST EDITION, OR AS APPROVED BY THE FEDERAL HIGHWAY ADMINISTRATION.
  - TRAFFIC CONTROL DEVICES SHALL BE SET UP JUST BEFORE THE START OF CONSTRUCTION OPERATIONS AND SHALL BE PROPERLY MAINTAINED DURING THE TIME SUCH CONDITIONS EXIST. THEY SHALL REMAIN IN PLACE ONLY AS LONG AS NEEDED AND REMOVED THEREAFTER.
  - EXISTING SIGNS AND CONSTRUCTION SIGNS SHALL BE KEPT IN PROPER POSITION, AND BE CLEAN AND LEGIBLE AT ALL TIMES. SIGNS THAT DO NOT APPLY TO EXISTING CONDITIONS SHALL BE REMOVED. SIGNS THAT ARE DAMAGED, DEFACED, OR THAT ACCUMULATE DIRT DURING CONSTRUCTION SHALL BE CLEANED, REPAIRED, OR REPLACED.
  - SIGNS ARE USUALLY MOUNTED ON A SINGLE POST, ALTHOUGH THOSE WIDER THAN 36" OR LARGER THAN 10 SQ. FT. SHALL BE MOUNTED ON TWO POSTS OR ABOVE A TYPE III BARRICADE.
  - SIGN POSTS DIRECT BURIED IN SOIL SHALL BE 2 LB. MINIMUM CHANNEL POST OR 4"x4" WOOD POSTS. CHANNEL POSTS SHALL BE PAINTED GREEN. WOOD POSTS SHALL BE PAINTED WHITE. ALL POSTS SHALL BE NEATLY CONSTRUCTED, AND SHALL BE REPLUMBED, CLEANED, OR REPAIRED AS NEEDED FOR THE DURATION OF THE JOB. THERE SHALL NOT BE MORE THAN 2 POSTS IN A 7' PATH FOR WOOD OR CHANNEL POSTS. ANY CHANNEL POST SPLICE SHALL BE IN ACCORDANCE WITH STANDARD DRAWING TC-3.
  - POST MOUNTED SIGNS IN RURAL AREAS SHALL BE CONSTRUCTED WITH THE NEAR EDGE OF THE SIGN FROM 6 TO 12 FEET FROM THE PAVEMENT EDGE. SIGNS IN URBAN AREAS AND BARRICADE MOUNTED SIGNS SHALL BE MOUNTED A MINIMUM OF 2 FEET FROM THE PAVEMENT EDGE.
  - ALL POST AND BARRICADE MOUNTED SIGNS MOUNTED IN URBAN AREAS SHALL BE MOUNTED A MINIMUM DISTANCE OF 7' FROM THE BOTTOM OF THE SIGN TO THE ROADWAY SURFACE. ALL POST AND BARRICADE MOUNTED SIGNS MOUNTED IN RURAL AREAS SHALL BE MOUNTED A MINIMUM DISTANCE OF 7' FROM THE BOTTOM OF THE SIGN TO THE ROADWAY SURFACE, EXCEPT A MINIMUM OF 6' SHALL BE USED WHEN MOUNTING AN ADVISORY SIGN BELOW A WARNING SIGN. TEMPORARY SIGNS MAY BE MOUNTED ON PORTABLE SUPPORTS FOR INTERMEDIATE TERM STATIONARY WORK CONDITIONS. THE SIGNS MINIMUM MOUNTING HEIGHT SHALL BE 5'. RETROREFLECTIVE DEVICES SHALL BE USED. TEMPORARY SIGNS MAY BE MOUNTED ON PORTABLE SUPPORTS FOR SHORT-TERM, SHORT DURATION, AND MOBILE CONDITIONS. THEY SHALL BE NO LESS THAN ONE (1) FOOT ABOVE THE TRAVELED WAY. LONG-TERM STATIONARY SIGNS SHALL BE DIRECT BURIED IN SOIL, UNLESS CONDITIONS NECESSITATE THE USE OF PORTABLE SIGNS, OR AS APPROVED BY THE ENGINEER. CONCRETE PADS, CONCRETE OR ROCK BALLAST, OR OTHER SOLID MATERIALS SHALL NOT BE UTILIZED WITH PORTABLE SIGN SUPPORTS.
  - FLAGGERS SHALL USE REFLECTORIZED STOP-SLOW PADDLES. FLAGS MAY BE USED ONLY FOR EMERGENCY SITUATIONS.
  - MOST OF THE SIGNS SHOWN ARE ORIENTED TO THE RIGHT. HOWEVER, THIS DOES NOT PRECLUDE THE USE OF MIRROR IMAGES OF THESE SIGNS WHERE THE REVERSE ORIENTATION MIGHT BETTER CONVEY TO MOTORISTS THE PROPER DIRECTION OF MOVEMENT.
  - R55-1 SIGNS SHALL BE PLACED AT LEAST 1500' BUT NOT MORE THAN 1 MILE IN ADVANCE OF THE WORK ZONE. IF A SPEED LIMIT REDUCTION IS IN EFFECT, THE SIGN SHALL BE PLACED A MINIMUM OF 500' IN ADVANCE OF THE "REDUCED SPEED AHEAD" SIGN.

NOTE: SUPPORTS FOR SIGNS, BARRICADES, AND VERTICAL PANELS THAT ARE DIFFERENT FROM THE REQUIREMENTS SHOWN IN NOTES 4 & 5, BUT MEET THE REQUIREMENTS OF NCHRP-350 OR MANUAL FOR ASSESSING SAFETY HARDWARE (MASH), WILL BE ACCEPTED. COMPLIANCE WITH THE REQUIREMENTS OF NCHRP-350 OR MANUAL FOR ASSESSING SAFETY HARDWARE (MASH) IS REQUIRED FOR ALL PROJECTS.

9-2-15	REVISED REDUCED SPEED LIMIT AHEAD SIGNS REVISED ROAD WORK NEXT XX MILES	
12-15-1	REVISED W24-1	
1-17-10	DELETED W8-9a & ADDED W8-9	
10-15-09	ADDED REFERENCE TO MASH & ADDED SIGN W24-1	
4-17-08	REVISED SIGN DESIGNATIONS	
8-18-04	REVISED NOTES	
10-9-03	REVISED NOTE 1	
1-16-01	REVISED NOTE 7	
9-28-00	REVISED NOTE	
8-18-98	ADDED NOTE	
6-26-97	REVISED NOTE 5	
4-03-97	REVISED NOTE 5	
10-18-96	ADDED CONTROLLED ACCESS HWY. SIGN & TO NOTE 7	
10-12-95	ADDED R55-1	
6-8-95	REVISED TO CORRECT SIGN ILLUSTRATIONS	6-8-95
2-2-95	REVISED PER PART VI, MUTCD SEPT. 3, 1993	
8-15-91	DRAWN AND PLACED IN USE	
DATE	REVISION	FILMED

ARKANSAS STATE HIGHWAY COMMISSION  
STANDARD TRAFFIC CONTROLS  
FOR HIGHWAY CONSTRUCTION  
STANDARD DRAWING TC-1

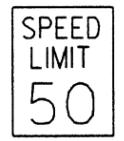
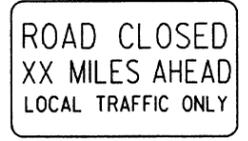
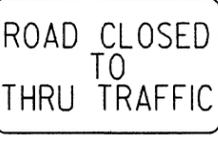
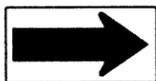
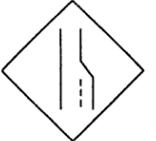
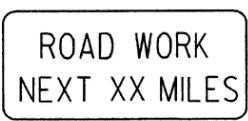
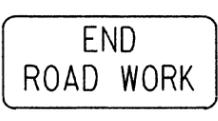
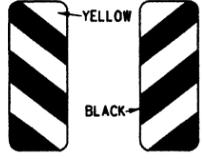
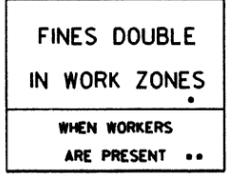
<p>RI-1</p>  <p>STANDARD 30"x30" EXPRESSWAY 36"x36" SPECIAL 48"x48"</p>	<p>RI-2</p>  <p>STD. 36"x36"x36" EXPWY. 48"x48"x48" FWY. 60"x60"x60"</p>	<p>R2-1</p>  <p>STD. 24"x30" EXPWY. 36"x48" FWY. 48"x60"</p>	<p>W3-5</p>  <p>STD. 36"x36" EXPWY. 48"x48" FWY. 48"x48"</p>	<p>W3-5a</p>  <p>STD. 36"x36" EXPWY. 48"x48" FWY. 48"x48"</p>	<p>R4-1</p>  <p>STD. 24"x30" EXPWY. 36"x48" FWY. 48"x60"</p>	<p>R4-2</p>  <p>STD. 24"x30" EXPWY. 36"x48" FWY. 48"x60"</p>	
<p>R5-1</p>  <p>STD. 30"x30" EXPWY. 36"x36" SPECIAL 48"x48"</p>	<p>R11-2</p>  <p>48"x30"</p>	<p>R11-3A</p>  <p>60"x30"</p>	<p>R11-4</p>  <p>60"x30"</p>	<p>RSP-1</p>  <p>48"x30"</p>	<p>W1-1</p>  <p>STD. 36"x36" FWY. 48"x48"</p>	<p>W1-2</p>  <p>STD. 36"x36" FWY. 48"x48"</p>	
<p>W1-3</p>  <p>STD. 48"x48"</p>	<p>W1-4</p>  <p>STD. 48"x48"</p>	<p>W1-6</p>  <p>STD. 48"x24" SPECIAL 60"x30"</p>	<p>W1-8</p>  <p>STD. 18"x24" SPECIAL 24"x30" EXPWY. 30"x36" FWY. 36"x48"</p>	<p>W3-1</p>  <p>STD. 36"x36" SPECIAL 48"x48"</p>	<p>W3-2</p>  <p>STD. 36"x36" SPECIAL 48"x48"</p>	<p>W4-2</p>  <p>STD. 36"x36" FWY. 48"x48"</p>	
<p>W5-1</p>  <p>STD. 36"x36" SPECIAL 48"x48"</p>	<p>W6-3</p>  <p>EXPWY. 36"x36" SPECIAL 48"x48"</p>	<p>W8-7</p>  <p>EXPWY. 36"x36" FWY. 48"x48"</p>	<p>W9-2</p>  <p>STD. 36"x36" FWY. 48"x48"</p>	<p>W13-1</p>  <p>STD. 24"x24"</p>	<p>W20-1</p>  <p>STD. 48"x48"</p>	<p>W20-2</p>  <p>STD. 48"x48"</p>	<p>W20-3</p>  <p>STD. 48"x48"</p>
<p>W20-4</p>  <p>STD. 48"x48"</p>	<p>W20-5</p>  <p>STD. 48"x48"</p>	<p>W20-7a</p>  <p>STD. 36"x36" FWY. 48"x48"</p>	<p>W21-2</p>  <p>STD. 30"x30" SPECIAL 36"x36"</p>	<p>W21-5</p>  <p>STD. 30"x30" SPECIAL 36"x36"</p>	<p>W24-1</p>  <p>STD. 36"x36"</p>	<p>W1-4b</p>  <p>STD. 48"x48"</p>	<p>R56-1</p>  <p>STD. 18"x18"</p>
<p>W8-11</p>  <p>STD. 36"x36" FWY. 48"x48"</p>	<p>W8-9</p>  <p>STD. 36"x36" FWY. 48"x48"</p>	<p>G20-1</p>  <p>60"x24"</p>	<p>G20-2</p>  <p>48"x24"</p>	<p>OM-3L OM-3R</p>  <p>12"x36"</p>	<p>M4-9</p>  <p>STD. 30"x24" SPECIAL 48"x36" SPECIAL 60"x48"</p>	<p>M4-10</p>  <p>48"x18"</p>	<p>R55-1</p>  <p>36"x60" • USE 6" C LETTERS •• USE 4" D LETTERS</p>

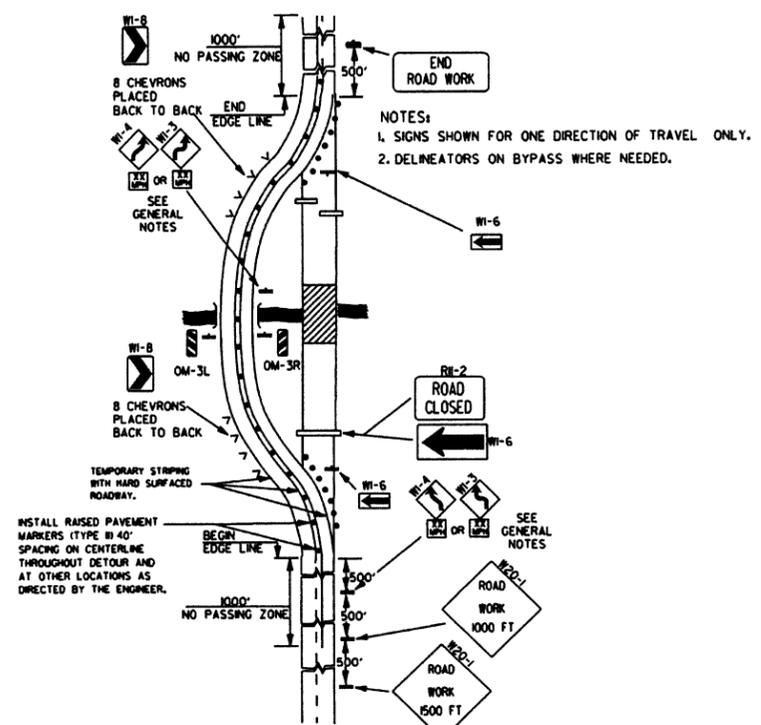

(A) TYPICAL APPLICATION OF TRAFFIC CONTROL DEVICES ON A 2-LANE HIGHWAY WHERE THE ENTIRE ROADWAY IS CLOSED AND A BYPASS DETOUR IS PROVIDED.

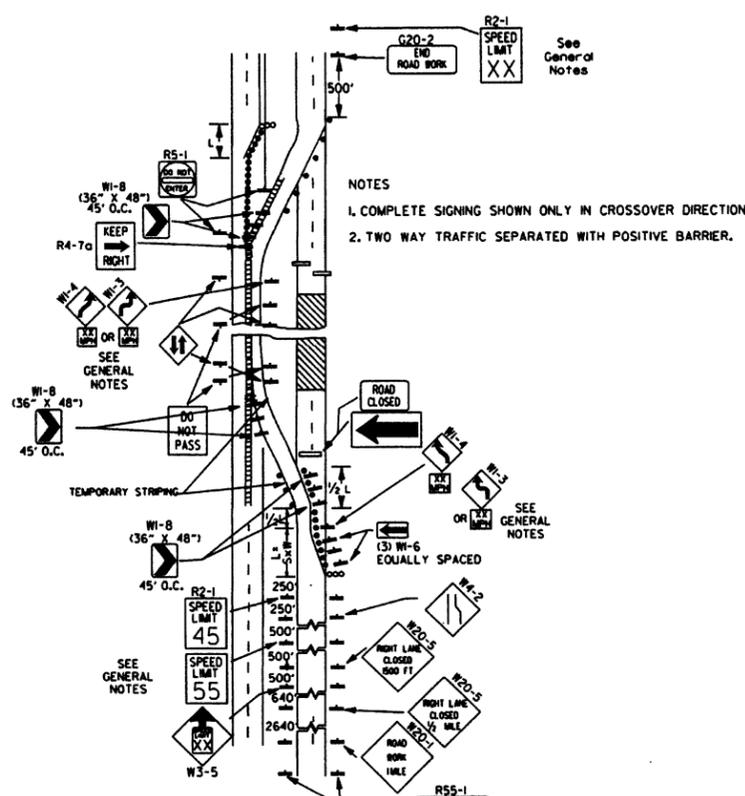

(B) TYPICAL APPLICATION - 4-LANE DIVIDED ROADWAY WHERE ONE ROADWAY IS CLOSED.

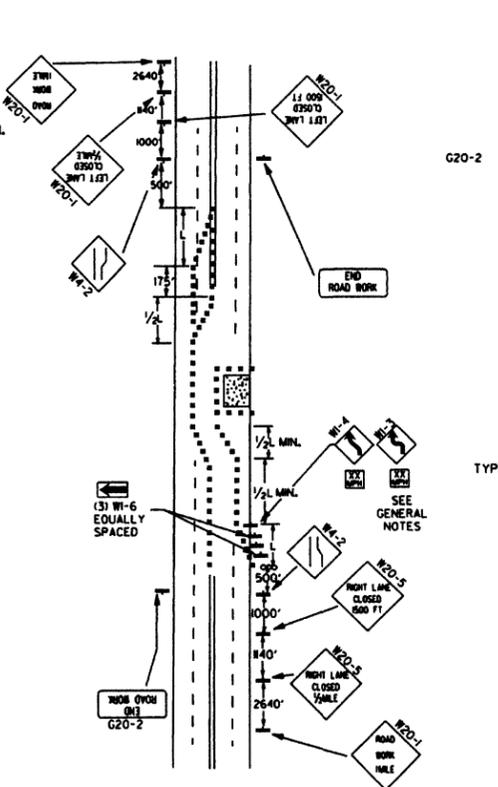

(C) TYPICAL APPLICATION - 4-LANE UNDIVIDED ROADWAY WHERE HALF OF THE ROADWAY IS CLOSED.

- KEY:**
- FLAGGER
  - POSITIVE BARRIER
  - ARROW PANEL (IF REQUIRED)
  - TYPE III BARRICADE
  - CHANNELIZING DEVICE
  - TRAFFIC DRUM
  - RAISED PAVEMENT MARKER

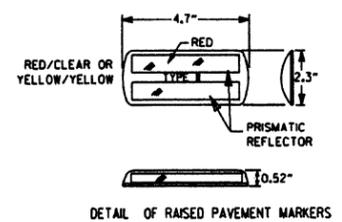

TYPICAL ADVANCE WARNING SIGN PLACEMENT

**TAPER FORMULAE:**  
 $L = SXW$  FOR SPEEDS OF 45MPH OR MORE.  
 $L = \frac{WS^2}{60}$  FOR SPEEDS OF 40MPH OR LESS.  
 WHERE:  
 L = MINIMUM LENGTH OF TAPER.  
 S = NUMERICAL VALUE OF POSTED SPEED LIMIT PRIOR TO WORK OR 85TH PERCENTILE SPEED.  
 W = WIDTH OF OFFSET.

- GENERAL NOTES:**
- ADVISORY SPEED POSTED ON W1-3 OR W1-4 CURVE WARNING SIGNS TO BE DETERMINED AT SITE. USE W1-4 WHEN SPEED IS GREATER THAN 30MPH AND W1-3 WHEN 30MPH OR LESS.
  - WHEN THE EXISTING SPEED LIMIT IS 55MPH AND THE PLANS REQUIRE A SPEED LIMIT OF 45MPH, THE R2-(K55) SHALL BE OMITTED AND THE W3-5 SHALL BE INSTALLED AT THAT LOCATION. ADDITIONAL R2-145MPH SPEED LIMIT SIGNS SHALL BE INSTALLED AT A MAXIMUM OF 1MILE INTERVALS. AT THE END OF THE WORK AREA A R2-(KXX) SHALL BE INSTALLED TO MATCH ORIGINAL SPEED LIMIT.
  - WHEN THE EXISTING SPEED LIMIT IS 65MPH AND THE PLANS REQUIRE A SPEED LIMIT OF 55MPH, THE R2-(K45) SHALL BE OMITTED. ADDITIONAL R2-155MPH SPEED LIMIT SIGNS SHALL BE INSTALLED AT A MAXIMUM OF 1MILE INTERVALS. AT THE END OF THE WORK AREA A R2-(KXX) SHALL BE INSTALLED TO MATCH ORIGINAL SPEED LIMIT.
  - THE MAXIMUM SPACING BETWEEN CHANNELIZING DEVICES IN A TAPER SHOULD BE APPROXIMATELY EQUAL IN FEET TO THE SPEED LIMIT, BEYOND THE TAPER, MAXIMUM SPACING SHALL BE TWO TIMES THE SPEED LIMIT, OR AS DIRECTED BY THE ENGINEER.
  - WARNING LIGHTS AND/OR FLAGS MAY BE MOUNTED TO SIGNS OR CHANNELIZING DEVICES AT NIGHT AS NEEDED.
  - PAVEMENT MARKINGS NO LONGER APPLICABLE WHICH MIGHT CREATE CONFUSION IN THE MINDS OF VEHICLE OPERATORS SHALL BE REMOVED OR OBLITERATED AS SOON AS PRACTICABLE.
  - TRAILER MOUNTED DEVICES SUCH AS ARROW PANELS AND PORTABLE CHANGEABLE MESSAGE SIGNS SHALL BE DELINEATED BY AFFIXING CONSPICUITY MATERIAL IN A CONTINUOUS LINE ON THE FACE OF THE TRAILER. WHEN PLACED ON OR ADJACENT TO THE SHOULDER AND NOT BEHIND A POSITIVE BARRIER, THESE DEVICES SHALL BE DELINEATED BY PLACING FIVE (5) TRAFFIC DRUMS, EQUALLY SPACED ALONG THE TRAFFIC SIDE OF THE DEVICE.
  - DIMENSIONS SHOWN FOR RAISED PAVEMENT MARKERS ARE TYPICAL. THE CONTRACTOR MAY SUBSTITUTE SIMILAR MARKERS WITH THE APPROVAL OF THE ENGINEER. REQUESTING APPROVAL FOR SIMILAR MARKERS MAY BE MADE BY REFERRING TO THE AHTD QUALIFIED PRODUCTS LIST.

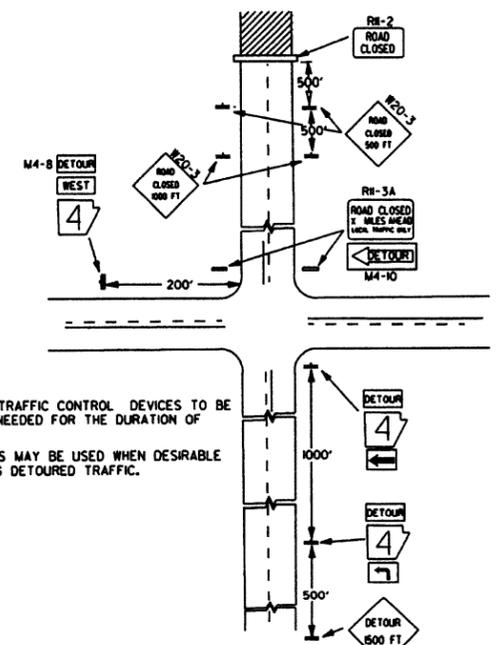

- NOTES:**
- REGULATORY TRAFFIC CONTROL DEVICES TO BE MODIFIED AS NEEDED FOR THE DURATION OF THE DETOUR.
  - STREET NAMES MAY BE USED WHEN DESIRABLE FOR DIRECTING DETOURED TRAFFIC.

(D) TYPICAL APPLICATION - ROADWAY CLOSED BEYOND DETOUR POINT.

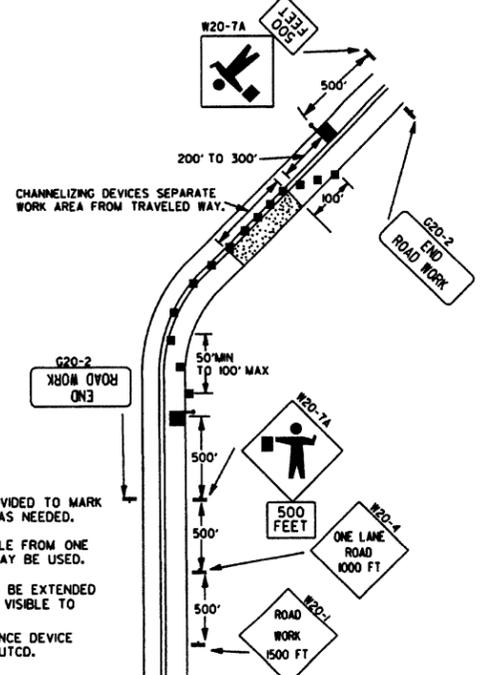

- NOTES:**
- FLOOD LIGHTS SHOULD BE PROVIDED TO MARK FLAGGER STATIONS AT NIGHT AS NEEDED.
  - IF ENTIRE WORK AREA IS VISIBLE FROM ONE STATION, A SINGLE FLAGGER MAY BE USED.
  - CHANNELIZING DEVICES ARE TO BE EXTENDED TO A POINT WHERE THEY ARE VISIBLE TO APPROACHING TRAFFIC.
  - AUTOMATED FLAGGER ASSISTANCE DEVICE (AFAD) OPTIONAL. REFER TO MUTCD.

(E) TYPICAL APPLICATION OF TRAFFIC CONTROL DEVICES ON 2-LANE HIGHWAY WHERE ONE LANE IS CLOSED AND FLAGGING IS PROVIDED.

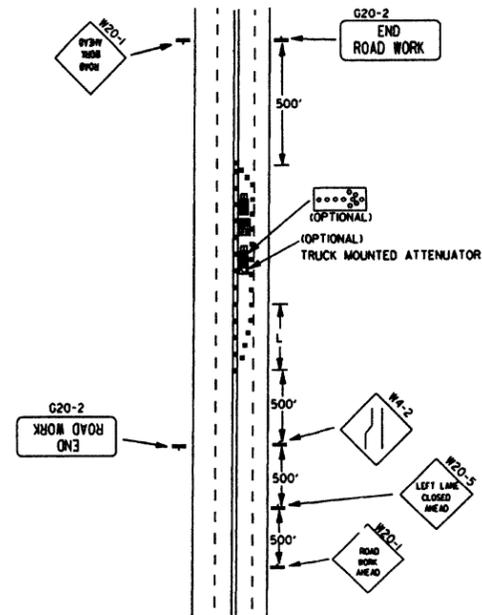

(F) TYPICAL APPLICATION - 4-LANE UNDIVIDED ROADWAY WITH INSIDE LANE CLOSED.

9-2-15	REVISED NOTE 2, ADDED NOTE 8, REVISED DRAWING (A) & REPLACED R2-5A WITH R3-5	
9-12-13	REVISED DETAIL OF RAISED PAVEMENT MARKERS	
3-1-10	ADDED (AFAD)	
8-20-08	REVISED SIGN DESIGNATIONS	
11-18-04	ADDED GENERAL NOTE	
10-18-96	ADDED R55-1	
4-26-96	CORRECTED (a) BEHIND G20-2	
6-8-95	CORRECTED SIGN IDENT. ON W1-4A	6-8-95
2-2-95	REVISED PER PART VI, MUTCD, SEPT. 3, 1993	
8-15-91	DRAWN AND PLACED IN USE	
DATE	REVISION	FILMED

ARKANSAS STATE HIGHWAY COMMISSION  
 STANDARD TRAFFIC CONTROLS  
 FOR HIGHWAY CONSTRUCTION  
 STANDARD DRAWING TC-2

Channelizing devices

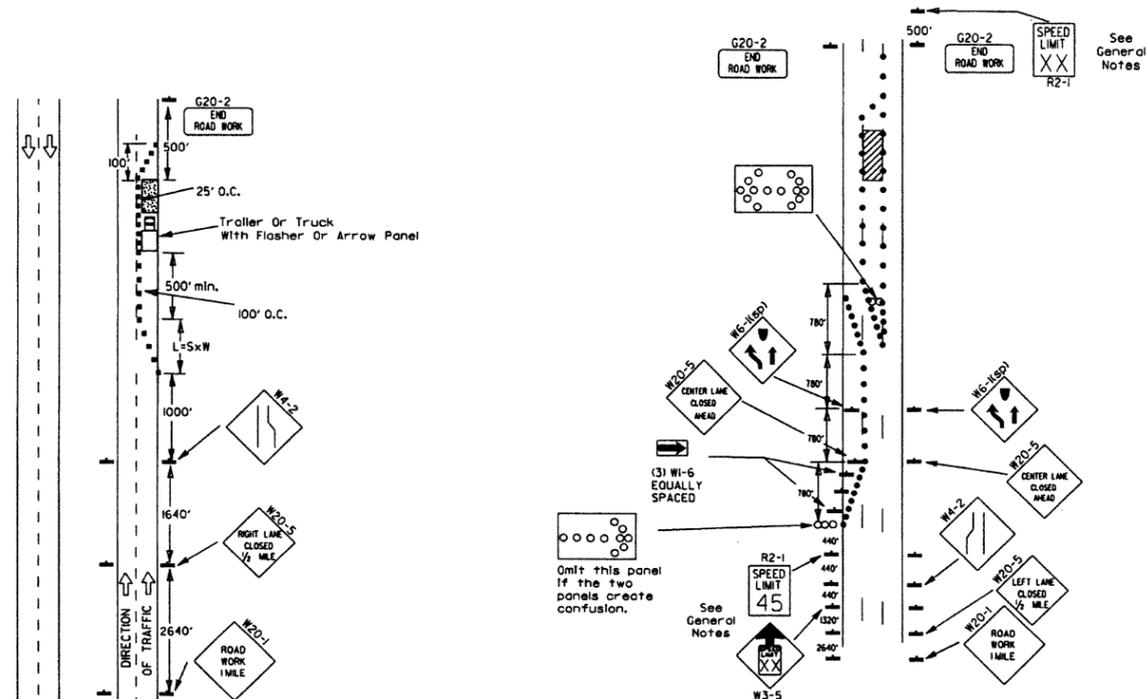

(A) Typical application - daytime maintenance operations of short duration on a 4-lane divided roadway where half of the roadway is closed.

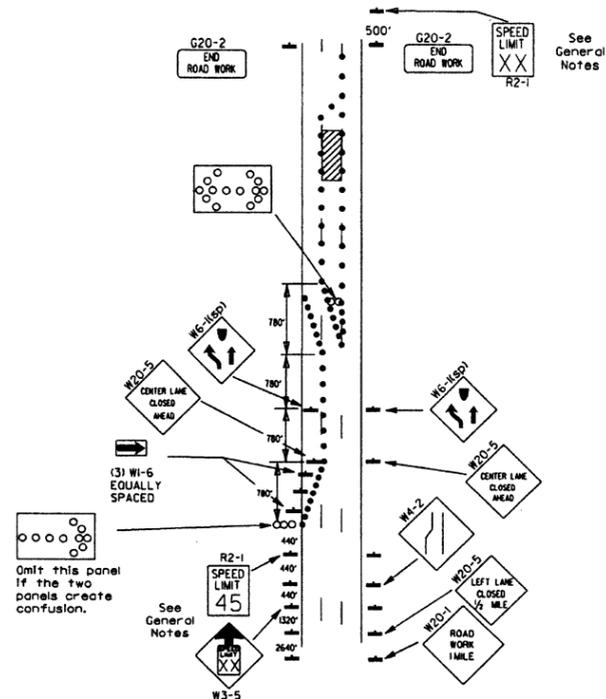

(B) Typical application - 3-lane oneway roadway where center lane is closed.

- KEY:
- Arrow Panel (if Required)
  - Channelizing Device
  - Traffic drum

GENERAL NOTES:

1. A speed limit reduction may be implemented ONLY when designated in the plan or when recommended by the Roadway Design Division.
2. When the existing speed limit is 55mph and the plans require a speed limit of 45mph, the R2-1(55) shall be omitted and the W3-5 shall be installed at that location. Additional R2-145mph speed limit signs shall be installed at a maximum of 1/2 mile intervals. At the end of the work area a R2-1(XX) shall be installed to match original speed limit.
3. When the existing speed limit is 65mph and the plans require a speed limit of 55mph, the R2-1(45) shall be omitted. Additional R2-155mph speed limit signs shall be installed at a maximum of 1/2 mile intervals. At the end of the work area a R2-1(XX) shall be installed to match original speed limit.
4. The maximum spacing between channelizing devices in a taper should be approximately equal in feet to the speed limit. Beyond the taper, maximum spacing shall be two times the speed limit or as directed by the Engineer.
5. Warning lights and/or flags may be mounted to signs or channelizing devices at night as needed.
6. Pavement markings no longer applicable which might create confusion in the minds of vehicle operators shall be removed or obliterated as soon as practicable.
7. The G20-1 sign will be required on jobs of over two miles in length. When the lane closure is not at the beginning of the project, the G20-1 sign shall be erected 125' in advance of the job limit. Additional W20-1(1/2 MILE) signs are not required in advance of lane closures that begin inside the project limits.
8. Flaggers shall use STOP/SLOW paddles for controlling traffic through work zones. Flags may be used only for emergency situations.
9. All plastic drums and cones shall meet the requirements of NCHRP-350 or Manual For Assessing Safety Hardware (MASH).
10. Trailer mounted devices such as arrow panels and portable changeable message signs shall be delineated by affixing conspicuity material in a continuous line on the face of the trailer. When placed on or adjacent to the shoulder and not behind a positive barrier, these devices shall be delineated by placing five (5) traffic drums, equally spaced along the traffic side of the device.

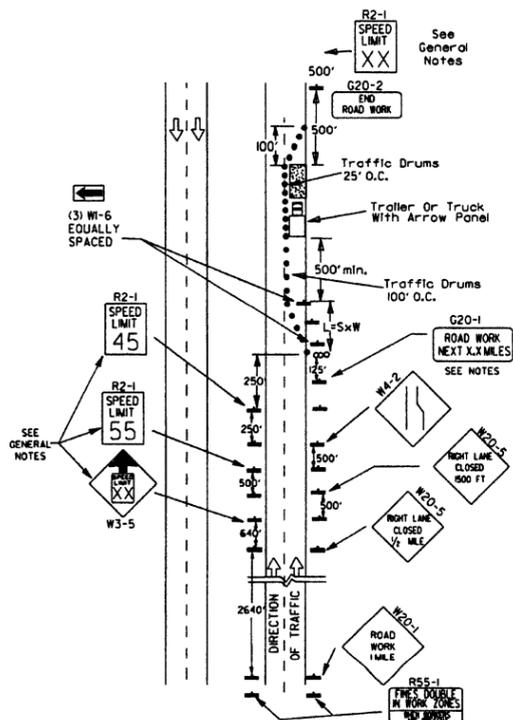

(C) Typical application - construction operations of intermediate to long term duration on a 4-lane divided roadway where half of the roadway is closed.

When cones are used on freeways and multi-lane highways, they shall be 28" min. During hours of darkness, 28" cones shall be used on all roadways, and shall be reflectorized in accordance with the M.U.T.C.D.

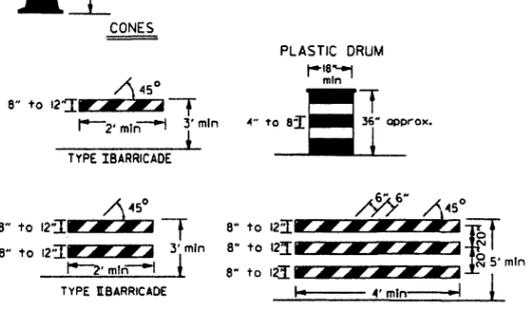

NOTE: For all road closures, the Type III barricades shall be of sufficient length to extend across entire roadway.

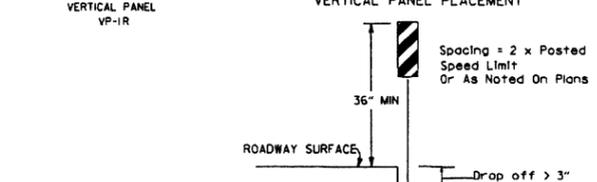

TRAFFIC CONTROL DEVICES FOR VERTICAL PAVEMENT DIFFERENTIALS

VERTICAL DIFFERENTIAL	LOCATIONS	TRAFFIC CONTROL
1" to 3"	Centerline, lane lines	W8-11
1" to 3"	Edge of shoulder	W8-9
Greater than 3"	Lane lines	Standard lane closure required
Greater than 3"	Edge of traveled lane	*RSP-1 and vertical panels, drums or concrete barrier
Greater than 3"	Edge of shoulder	*Vertical panels, drums or concrete barrier

\* When shown on the plans concrete barrier will be used. When the shoulder area is used as part of the traveled lane and there is insufficient width to place drums on the remaining shoulder width, then vertical panels shall be used.



STOP SLOW PADDLE

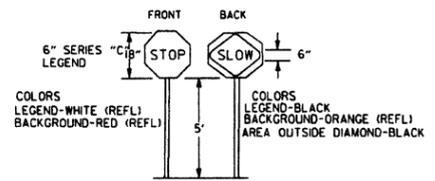

DETAIL OF SPLICES

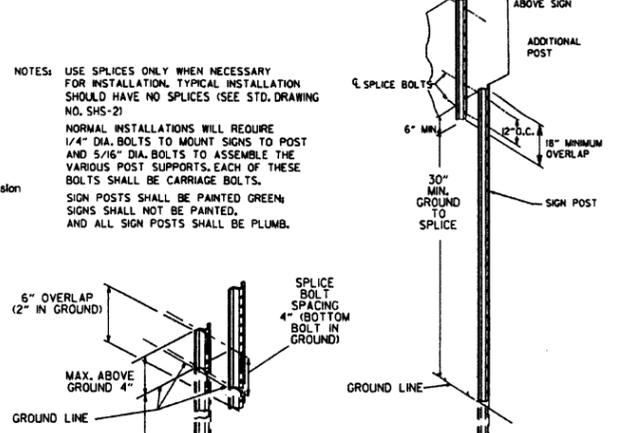

NOTES: USE SPLICES ONLY WHEN NECESSARY FOR INSTALLATION. TYPICAL INSTALLATION SHOULD HAVE NO SPLICES (SEE STD. DRAWING NO. SHS-2). NORMAL INSTALLATIONS WILL REQUIRE 1/4" DIA. BOLTS TO MOUNT SIGNS TO POST AND 5/16" DIA. BOLTS TO ASSEMBLE THE VARIOUS POST SUPPORTS. EACH OF THESE BOLTS SHALL BE CARRIAGE BOLTS. SIGN POSTS SHALL BE PAINTED GREEN. SIGNS SHALL NOT BE PAINTED, AND ALL SIGN POSTS SHALL BE PLUMB.

DATE	REVISION	FILMED
9-2-15	REVISED NOTE 2 & REPLACED R2-5A WITH W3-5	
10-15-09	ADDED REFERENCE TO MASH	
11-20-08	REVISED SIGN DESIGNATIONS	
11-18-04	ADDED NOTE	
10-1-98	ADDED NOTE	
4-03-97	ADDED (SP) TO W6-1 & REVISED TRAFFIC CONTROL DEVICES NOTE	
10-18-96	ADDED R55-1	
10-12-95	MOVED UPPER SPLICE	
6-8-95	REVISED SPLICE DETAIL, TEXT	6-8-95
2-2-95	REVISED PER PART VI, MUTCD, SEPT. 3, 1993	
8-15-91	DRAWN AND PLACED IN USE	

ARKANSAS STATE HIGHWAY COMMISSION  
STANDARD TRAFFIC CONTROLS FOR HIGHWAY CONSTRUCTION  
STANDARD DRAWING TC-3

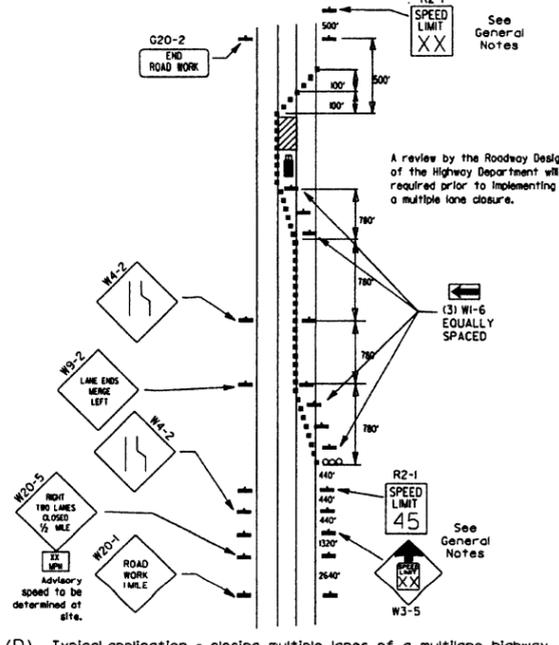

(D) Typical application - closing multiple lanes of a multilane highway.